

LEA

CERAMICHE

catalogo 2014

INDICE / index / index / inhalt / indice

SLIMTECH

wood-stock	<i>antibatterico</i>	16
type-32	<i>design by Diego Grandi</i>	28
RE-evolution		34
gouache.10	<i>design by Diego Grandi</i>	46
studies in gouache	<i>design by Diego Grandi</i>	58
shade		68
streets in shade	<i>design by Diego Grandi</i>	74
arenaria		76
basaltina stone project		86
lines	<i>design by Patrick Norguet</i>	96
waves	<i>design by Patrick Norguet</i>	100
mauk	<i>design by Diego Grandi</i>	104

SUPERFICI CONTEMPORANEE

metropolis	<i>antibatterico</i>	110
arenaria	<i>antibatterico</i>	124
salento	<i>antibatterico</i>	132
blue mountain		140
basaltina stone project		150
makò		160
stonehenge		168
city	<i>design by Diego Grandi</i>	176

MARMI, PORFIDI E SLATE

origini	<i>antibatterico</i>	182
dreaming		192
storm		202
outdoor		210
tecnoquartz		216
rain forest		226
ancient jerusalem		234

ECOLEGNI

bio timber	<i>antibatterico</i>	242
bio plank	<i>antibatterico</i>	252
bioessenze		262

RIVESTIMENTI

kensington		272
mayfair		284
kalos		292
athena		300
pleasures		306
audrey		314
très jolie		326
progetto L14	<i>design by Gianluca Soddu</i>	332
goccia	<i>design by Kravitz Design Inc.</i>	340
paillettes		348
tesserae		354

APPENDICE TECNICA

certificazioni	362
caratteristiche tecniche	384
protezione antibatterica microban	396
posa elemento elle e gradino continuo	398
informazioni per la pulizia e la manutenzione	404
imballi	425
condizioni generali di vendita	438
disclaimer	440

INDICE ALFABETICO

ancient jerusalem	234
arenaria	124
arenaria slimtech	76
athena	300
audrey	314
basaltina stone project	150
basaltina stone project slimtech	86
bioessenze	262
bio plank	252
bio timber	242
blue mountain	140
city	176
dreaming	192
goccia	340
gouache.10 slimtech	46
kalos	292
kensington	272
lines slimtech	96
makò	160
mauk slimtech	104
mayfair	284
metropolis	110
origini	182
outdoor	210
paillettes	348
pleasures	306
progetto L14	332
rain forest	226
RE-evolution slimtech	34
salento	132
shade slimtech	68
stonehenge	168
storm	202
studies in gouache slimtech	58
streets in shade slimtech	74
tecnoquartz	216
tesserae	354
très jolie	326
type-32 slimtech	28
waves slimtech	100
wood-stock slimtech	16

LEGENDA TECNICA

technical notice
légende technique
erläuterung der technischen begriffe
leyenda técnica

ITA

ENG

SUPPORTO

GRES TUTTA MASSA UGL

prodotto che mostra in superficie esattamente i colori che attraversano tutto il corpo della piastrella.

GRES SMALTATO A MASSA COLORATA GL

prodotto colorato negli impasti del corpo della piastrella ulteriormente arricchito da applicazioni di smaltatura sulla superficie.

MONOPOROSA IN PASTA BIANCA SMALTATA GL

prodotto destinato al rivestimento con impasto poroso di colore biancastro, monocoloro, smaltato e colorato solo in superficie.

GRES SMALTATO GL

prodotto in gres porcellanato monocoloro di base che viene colorato in superficie esclusivamente attraverso lo smalto.

GRES LAMINATO UGL

prodotto in gres porcellanato tutta massa frutto di una tecnologia innovativa di compattazione, dotato di caratteristiche uniche di dimensioni, spessore, leggerezza, resistenza e flessibilità.

DOPPIA PRESSATURA

processo produttivo che miscela i differenti colori degli impasti del corpo piastrella in una prima pressatura e compatta i colori delle applicazioni successive attraverso una seconda ulteriore pressatura.

BORDO

NATURALE (nat)

bordo derivato esclusivamente dalla formatura della pressa.

RETTIFICATO MONOCALIBRO (rett)

bordo perfettamente rettilineo (a volte accompagnato da un lieve bisello sul perimetro di superficie) derivante da lavorazione di squadratura che riporta i pezzi ad un'unica dimensione dei lati, indipendentemente dai lotti produttivi.

ANTICATO

bordo che replica un'irregolarità casuale attraverso lavorazioni meccaniche successive alla cottura.

GRADO DI STONALIZZAZIONE

indica la differenza di tono delle singole piastrelle come non omogenee tra di loro.

V1 uniforme - V2 lieve - V3 moderata - V4 forte

FINITURA DI SUPERFICIE

NATURALE (nat) - VELVET - SPAZZOLATO (spazz) - TEXTURE (txt):

superficie che non viene in alcun modo lavorata dopo la cottura.

LAPPATA (lapp):

superficie resa più scorrevole e lucente attraverso una lavorazione meccanica dopo la cottura.

LUX:

finitura superficiale lucida, ottenuta tramite leggera abrasione meccanica della superficie.

LEVIGATA (lev):

finitura superficiale lucida, ottenuta asportando un piccolo strato di materiale in modo da evidenziare le caratteristiche estetiche del supporto.

FUGA

distanza consigliata tra le piastrelle.

BASE

FULL-BODY PORCELAIN UGL

a product which has the same colours on the surface that pass through the body of the tile.

COLOURED BODY GLAZED PORCELAIN GL

a product which has a coloured body, further enhanced by glazed surface applications.

GLAZED WHITE-BODY POROUS SINGLE-FIRED TILES

a product designed for wall tiles with porous whitish body, single work-size, glazed and coloured only on the surface.

GLAZED PORCELAIN GL

a product in glazed, plain colour base stoneware, coloured on the surface exclusively through the glaze.

LAMINATED PORCELAIN UGL

full body porcelain produced using an innovative compacting technology, that offers unique characteristics in terms of dimension, thickness, lightness, resistance and flexibility.

DOUBLE PRESSING

a production process which combines the various colours of the tile body in a first pressing and compacts the subsequent application colours by means of a second, final pressing.

EDGE

NATURALE (nat)

an edge produced exclusively from the moulding of the press.

RECTIFIED, SINGLE WORK-SIZE (rett)

a perfectly straight edge (occasionally with a slight chamfer on the surface perimeter) obtained through the process of squaring, which matches the sides of the tiles perfectly, regardless of the production lot.

ANTICATO

an edge with a simulated casual irregular shape by means of mechanical processes following firing.

SHADING

indicates the different shades of colour between the single, non-homogeneous tiles.

V1 uniform - V2 slight - V3 moderate - V4 strong

SURFACE FINISH

NATURALE (nat) - VELVET - SPAZZOLATO (spazz) - TEXTURE (txt):

a surface which is not treated in any way after firing.

LAPPATA (lapp):

a smoother, shinier surface thanks to a special mechanical process after firing.

LUX:

shiny superficial finish, obtained through a light mechanical abrasion of the surface.

LEVIGATA (lev):

polished surface finish, achieved by removing a small layer of material in order to highlight the aesthetic characteristics of the surface.

JOINT

recommended gap between tiles.

FRA**SUPPORT**

GRÈS PLEINE MASSE UGL
carreau présentant à la surface exactement les mêmes couleurs qui traversent toute sa masse.

GRÈS ÉMAILLÉ À MASSE COLORÉE GL
carreau coloré dans la masse dont la surface a été ensuite enrichie par des émaillages.

CARREAU MONOPOREUX ÉMAILLÉ À PÂTE BLANCHE GL

carreau à pâte poreuse de couleur blanchâtre pour le revêtement des murs, monocalibre, émaillé et coloré uniquement en surface.

GRÈS ÉMAILLÉ GL

carreau en grès cérame avec base monochrome et surface colorée uniquement par l'émail.

GRÈS LAMINÉ UGL

produit en grès cérame pleine masse fruit d'une technologie innovante de compactation, doté de caractéristique unique de dimensions, épaisseur, légèreté, résistance et flexibilité.

DOUBLE PRESSAGE

procédé de fabrication qui mélange les différentes couleurs de la masse du carreau lors d'un premier pressage et compacte les couleurs dans des applications suivantes par une deuxième et dernière opération de pressage.

BORD

NATURALE (nat)

bord dont la forme n'est façonnée que par l'opération de pressage.

RECTIFIÉ MONOCALIBRE (rett)

bord parfaitement rectiligne (présentant quelque fois un léger biseau au périmètre) obtenu par un équarrissage qui donne aux pièces des côtés de même taille, indépendamment des lots de production.

ANTICATO

bord reproduisant une irrégularité fortuite obtenue par le biais de façonnages mécaniques après la cuisson.

VARIATION DE NUANCE

indique la différence de couleur présentée par des carreaux non homogènes.

V1 uniforme - V2 légère - V3 modérée - V4 prononcée.

FINITION DE SURFACE

NATURALE (nat) - VELVET - SPAZZOLATO (spazz)

- TEXTURE (txt):

surface qui n'a subi aucun traitement après la cuisson.

LAPPATA (lapp):

surface rendue plus fluide et plus brillante par le biais d'un traitement mécanique après la cuisson.

LUX:

finition de surface brillante, obtenue par le biais d'une légère abrasion mécanique de la surface.

LEVIGATA (lev):

finition de surface polie, obtenue en enlevant une faible couche en surface pour mettre en valeur les caractéristiques esthétiques du produit.

JOINT

distance conseillée entre les carreaux.

DEU**SCHERBEN**

VOLLGEMISCHTES FEINSTEINZEUG UGL

ein produkt, das auf der oberfläche genau die farben zeigt, die den gesamten fliesenkörper durchziehen.

GLASIERTES FEINSTEINZEUG MIT GEFÄRBTEN MASSE GL

ein produkt, bei dem die masse des fliesenkörpers gefärbt wurde und das zusätzlich eine glasur auf der oberfläche aufweist.

GLASIERTE, WEISSSCHERBIGE „MONOPOROSA“ GL

ein als wandfliese bestimmtes produkt mit poröser, weißlicher masse, das aus einem werkmaß hergestellt, glasiert und nur oberflächlich gefärbt wird.

GLASIERTES FEINSTEINZEUG GL

ein produkt aus einfarbigem grundfeinsteinzeug, das seine farbige oberfläche ausschließlich durch die glasur erhält.

LAMINIERTES FEINSTEINZEUG UGL

vollgemischtes durchgefärbtes feinsteinzeug, erzeugnis einer innovativen verdichtungstechnologie. dieses produkt enthält einzigartige eigenschaften bezüglich formaten, stärken, leichtigkeit, beständigkeit und flexibilität.

DOPPELTE PRESSUNG

ein produktionsprozess, der die verschiedenen farben der massen des fliesenkörpers in einem ersten pressvorgang mischt und dann die farben in den folgenden anwendungen durch eine zweite pressung verdichtet.

FLIESENRAD

NATURALE (nat)

ein rand, der ausschließlich durch die formung der presse entsteht.

IN EINEM WERKMASS GESCHLIFFEN (rett)

ein perfekt gerader rand (zum teil auch mit einer leichten abkantung an der oberfläche), der durch eine rechteckige bearbeitung entsteht, die die stücke, unabhängig zu welcher fertigungsscharge sie gehören, auf ein übereinstimmendes seitenmaß bringt.

ANTICATO

ein rand, dessen zufällige unregelmäßigkeiten durch eine mechanische bearbeitung nach dem brennvorgang entstehen.

FARBABSTUFUNG

gibt den unterschied der einzelnen fliesen an, deren farbtönen nicht übereinstimmt.

V1 gleichförmig - V2 leicht - V3 mässig - V4 stark

OBERFLÄCHENAUSFÜHRUNGEN

NATURALE (nat) - VELVET - SPAZZOLATO (spazz) -

TEXTURE (txt):

eine oberfläche, die nach dem brennvorgang nicht bearbeitet wird.

LAPPATA (lapp):

eine oberfläche, die durch eine mechanische bearbeitung nach dem brennvorgang glatt und glänzend wird.

LUX:

lux glänzende oberfläche durch eine leicht mechanischen bearbeitung erreicht.

LEVIGATA (lev):

polierte und glänzende oberfläche, ergebnis der entfernung einer kleinen materialschicht zur betonung der ästhetischen eigenschaften der oberfläche.

FUGE

der zwischen den fliesen empfohlene abstand.

ESP**INFORMACIÓN**

GRES TODA MASA UGL

producto que muestra en la superficie los mismos colores que atraviesan el cuerpo de la baldosa.

GRES ESMALTADO DE MASA COLORADA GL

producto colorado en los empastes del cuerpo de la baldosa y posteriormente enriquecido con aplicaciones de esmaltado sobre la superficie.

MONOPOROSA DE PASTA BLANCA ESMALTADA GL

producto destinado al revestimiento con empaste poroso de color blanquecino, monocalibre, esmaltado y colorado sólo en la superficie.

GRES ESMALTADO GL

producto de gres porcelánico en monocolor básico al que se da color en la superficie, exclusivamente a través del esmalte.

GRES LAMINADO UGL

gres toda masa producido mediante tecnologías innovadoras de compactación, que ofrece únicas características en términos de medidas, el espesor, la ligereza, resistencia y flexibilidad.

DOBLE PRENSADO

proceso productivo que mezcla los diferentes colores de los empastes del cuerpo de la baldosa en un primer prensado y compacta los colores de las aplicaciones sucesivas mediante un segundo prensado.

BORDE

NATURALE (nat)

borde que se deriva exclusivamente de la forma de la prensa.

RECTIFICADO MONOCALIBRE (rett)

borde perfectamente rectilíneo (a veces acompañado de un leve bisel sobre el perímetro de la superficie) derivado del trabajo de encuadre que produce las piezas con una única dimensión para los lados, independientemente de los lotes productivos.

ANTICATO

borde que repite una irregularidad casual mediante operaciones mecánicas después de la cocción.

GRADO DE TONALIZACIÓN

indica la diferencia de tono de baldosas individuales como si no fueran homogéneas entre ellas.

V1 uniforme - V2 leve - V3 moderado - V4 fuerte

ACABADO DE SUPERFICIE

NATURALE (nat) - VELVET - SPAZZOLATO (spazz) -

TEXTURE (txt):

superficie que no se trabaja de ningún modo después de la cocción.

LAPPATA (lapp):

superficie más deslizante y lúcida mediante una operación mecánica después de la cocción.

LUX:

acabado superficial pulido, obtenido por raspar suavemente la superficie.

LEVIGATA (lev):

acabado de la superficie "brillante", obtenida quitando un pequeño estrato de material para evidenciar las características estéticas del soporte.

JUNTA

distancia recomendada entre las baldosas.

LEGENDA CODICI

code notice
légende codes
erläuterung des artikels
leyenda codigos

ITA

ENG

CODICE ARTICOLO

L000000

CODICE PREZZO

0000 materiale venduto al mq

0000 materiale venduto al pz

PRODUCT CODE

L000000

PRICE CODE

0000 item sold by sqmt

0000 item sold by piece

FRA

DEU

ESP

CODE ARTICLE

L000000

ARTIKEL NUMMER

L000000

CODIGO

L000000

CODE PRIX

0000 article vendu au m²
0000 article vendu a la piece

PREIS ARTIKEL NUMMER

0000 artikel qm weise
0000 artikel stückweise

CODIGO PRECIO

0000 material vendido al mq
0000 material vendido a la pieza

SLIMTECH

16	WOOD-STOCK
28	TYPE-32
34	RE-evolution
46	GOUACHE.10
58	STUDIES IN GOUACHE
68	SHADE
74	STREETS IN SHADE
76	ARENARIA
86	BASALTINA STONE PROJECT
96	LINES
100	WAVES
104	MAUK

SLIMTECH

la rivoluzione del gres laminato
the revolution of laminated porcelain
la revolution du grès laminé
revolution des laminierten Feinsteinzeugs
la revolucion del gres laminado

ITA

ENG

LEA SLIMTECH è la soluzione che completa il progetto di superfici di Lea Ceramiche offrendo lastre di dimensioni record (100x300 cm) abbinata ad una straordinaria leggerezza grazie allo spessore di soli 3 e 5 mm.

E' il frutto di una tecnologia di laminazione e compattazione del gres porcellanato che rivoluziona il processo produttivo tradizionale ed ottiene così un prodotto completamente nuovo, resistente, leggero, flessibile, duttile e versatile.

LEA SLIMTECH soddisfa pienamente le esigenze più attuali della moderna progettazione sia per interni che per le ampie superfici esterne degli edifici contemporanei.

E' facile da installare e risolve, meglio di qualunque altro materiale, le problematiche del rinnovo offrendo risultati estetici eccellenti combinati a un costo complessivo contenuto.

LEA SLIMTECH is the creation that completes Lea Ceramiche's product range. Slimtech offers ceramic slabs in record sizes (100x300 cm) that are extraordinarily lightweight due to a thickness of only 3 and 5 mm.

Slimtech is the result of a laminating and compacting technology that has revolutionized the traditional productive process. The result is a completely new, resistant, lightweight, flexible, ductile and versatile product.

LEA SLIMTECH satisfies modern design needs for both internal covering and external cladding for buildings.

It is easy to install and repair, and it is the best solution for restructuring, offering great aesthetic finish with limited expenditure.

RESISTENTE
GRANDE
PLANARE
SOTTILE E LEGGERA
FACILE
AFFIDABILE
GARANTITA
ECOLOGICA

RESISTANT
LARGE
FLAT
THIN AND LIGHT
EASY
RELIABLE
GUARANTEED
ECOLOGICAL

FRA

LEA SLIMTECH est la solution qui complète le projet de surfaces de Lea Ceramiche en offrant des carreaux de dimensions record (100x300 cm) associées à une extraordinaire légèreté grâce à l'épaisseur de seulement 3 et 5 mm.

Elle est le fruit d'une technologie de laminage et compactage du grès cérame qui révolutionne le processus de production traditionnel et obtient ainsi un produit totalement nouveau, résistant, léger, flexible, ductile et polyvalent.

LEA SLIMTECH répond pleinement aux exigences les plus récentes de la conception moderne aussi bien pour l'intérieur que pour les vastes surfaces extérieures des édifices contemporains.

Elle est facile à installer et résout, mieux que tout autre matériau, les problématiques de la rénovation en offrant d'excellents résultats esthétiques accompagnés d'un coût global limité.

RESISTANT
GRAND
PLAT
FIN ET LÉGER
FACILE
FIABLE
GARANTI
ECOLOGIQUE

DEU

LEA SLIMTECH ist die perfekte Lösung, die das Angebot des Oberflächenprojekts des Unternehmens Lea Ceramiche ergänzt.

Bei Lea Slimtech handelt es sich um sehr großformatige Platten (100x300 cm), die sich durch ihre außergewöhnliche Leichtigkeit mit nur 3 und 5 mm Stärke auszeichnen. Sie sind das Ergebnis einer neuen Technik durch Walzung und Pressung des Porzellansteins, die den herkömmlichen Produktionsprozess revolutioniert, wodurch ein absolut neues, widerstandsfähiges, leichtes, flexibles, duktils und vielseitiges Produkt entsteht.

LEA SLIMTECH befriedigt die neuesten Anforderungen der modernen Projektierung im Innen- wie auch im Außenbereich an allen Oberflächen und Wänden zeitgenössischer Gebäude.

Die Platten sind leicht zu installieren und lösen, weitaus besser als andere Materialien, die Problematik der Erneuerung. Die ästhetischen Ergebnisse sind hervorragend und die allgemeinen Kosten beschränkt.

RESISTENT
GROSSE
PLANAR
DÜNNE UND LEICHT
EINFACH
ZUVERLÄSSIG
GARANTIERT
ÖKOLOGISCHE

ESP

LEA SLIMTECH es la solución que completa el diseño de las superficies de Lea Ceramiche ofreciendo losa de dimensiones récord (100x300 cm) combinadas con una extraordinaria ligereza gracias al grosor de sólo 3 y 5 mm.

Es el fruto de una tecnología de laminado y compactación del gres porcelanizado que revoluciona el proceso productivo tradicional y obtiene así un producto completamente nuevo, resistente, ligero, flexible, dúctil y versátil.

LEA SLIMTECH satisface por completo las exigencias actuales del diseño moderno ya sea para interiores o para las amplias superficies externas de los edificios contemporáneos.

Es fácil de instalar y resuelve los problemas de renovación mejor que cualquier otro material, ofreciendo resultados estéticos excelentes combinados con un precio total contenido.

RESISTENTES
GRANDES
LLANO
DELGADA Y LIGERO
FACIL
CONFIABLE
GARANTIZADOS
ECOLOGICO

SLIMTECH

Frutto di una tecnologia all'avanguardia, **Slimtech** viene prodotta in lastre di 100x300 cm spessore 3 e 5 mm, con un impasto di gres porcellanato composto da argille e materie prime pregiate.

È pressata con una forza di 15.000 tonnellate.

La cottura avviene in forni innovativi ed ecologici, frutto della ricerca e know-how Panariagroup.

Slimtech tile is the result of the latest technology. It is produced in the 100x300 cm size with a thickness of 3 and 5 mm, using a porcelain stoneware mixture composed of top quality clay and raw materials.

It is pressed using a force of 15.000 tons.

Firing takes place in innovative and environmental-friendly kilns, fruit of Panariagroup's research activities and know-how.

Réalisée grâce à une technologie de pointe, **Slimtech** est produite en dalles de 100x300 cm de 3 et 5 mm d'épaisseur, avec une pâte de grès cérame composée d'argile et de matières premières de grande qualité.

Elle est pressée avec une force de 15 000 tonnes.

La cuisson est effectuée dans une nouvelle génération de fours écologiques, construits grâce aux travaux de recherche et au savoir-faire de Panariagroup.



Resistente alle macchie e agenti chimici
Resistant to stains and chemical agents
Résistant aux taches et aux agents chimiques
Fleckenbeständig und chemikalienbeständig
Resistente a las manchas y a los agentes químicos

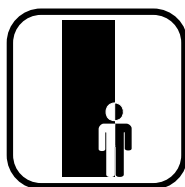

Dimensioni record, fino a 100x300 cm
Record dimensions, up to 100x300 cm
Dimensions record, jusqu'à 100x300 cm
Rekordabmessungen bis zu 100x300 cm
Dimensiones récord hasta 100x300 cm

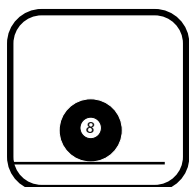

Planare
Planar
Planéité
Eben
Plana

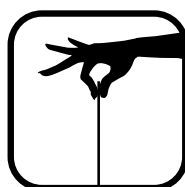

Una lastra sottile di soli 3 o 5 mm
A slab only 3 or 5 mm thick
Une dalle fine, de 3 ou 5 mm seulement
Eine nur 3 oder 5 mm dünne Platte
Una losa delgada de tan solo 3 o 5 mm

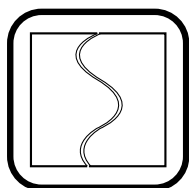

Facile da tagliare
Easy to cut
Facile à couper
Einfach zu schneiden
Fácil de cortar



Affidabile
Reliable
Fiable
Verlässlich
Fiable

Slimtech, das einer hochfortschrittlichen Technologie zu verdanken ist, wird in 100x300 cm großen Platten mit 3 und 5 mm Stärke aus einer Feinsteinzeugmasse aus hochwertigen Tonarten und Rohstoffen gefertigt. Die Platten werden mit 15.000 Tonnen Kraft gepresst. Der Brennvorgang erfolgt in innovativen, umweltfreundlichen Öfen, die auf der Forschung und dem Know-how von Panariagroup beruhen.

Fruto de una tecnología de vanguardia, **Slimtech** se produce en losas de 100x300 cm de 3 y 5 mm de espesor, con una masa de gres porcelánico compuesta de arcillas y materias primas de calidad. Prensada con una fuerza de 15.000 toneladas. La cocción se realiza en hornos innovadores y ecológicos, fruto de la investigación y del know-how Panariagroup.

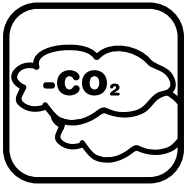

Nuova tecnologia, attenta all'ecologia
New technology, eco-friendly
Nouvelle technologie, respectueuse de l'environnement
Neue umweltfreundliche Technologie
Nueva tecnología, atenta a la ecología



Slimtech 3plus e 5plus resistono ad alto traffico
Slimtech 3plus and 5plus are ideal for high-traffic areas
Slimtech 3plus et 5plus sont résistantes au passage intensif
Slimtech 3Plus Und Slimtech 5Plus Widersteht auch Hohe Verkehr
Slimtech 3plus e 5plus resisten al tráfico intenso



Per rinnovare il rivestimento e pavimento
To easily renovate floors and walls
Pour renouveler le revêtement de sols et murs
Zur Erneuerung der Verkleidungen und Fußböden
Para renovar el revestimiento y el pavimento



Più mq per ogni carico
More sqm per shipment
Plus de m² à chaque chargement
Mehr m² für jede Ladung
Más m² por cada carga

SLIMTECH 3MM

solo per rivestimenti
wall applications only
pour revêtements de murs seulement
nur für Verkleidungen
solo para revestimientos

3mm

spessore
thickness
épaisseur
stärke
espesor



SLIMTECH 3PLUS

rinforzata con stuoia in fibra di vetro
reinforced with a sheet of fiberglass
renforcé au dos par une natte en fibre de verre
mit Glasfasermatte verstärkt
reforzada con un tejido de fibra de vidrio

3,5mm

spessore
thickness
épaisseur
stärke
espesor

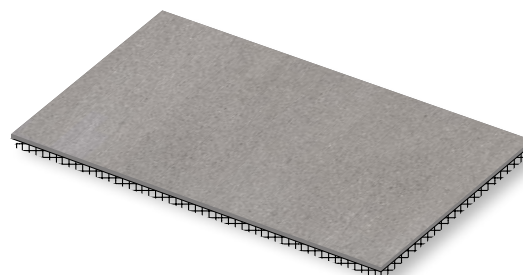

SLIMTECH 5PLUS

rinforzata con stuoia in fibra di vetro
reinforced with a sheet of fiberglass
renforcé au dos par une natte en fibre de verre
mit Glasfasermatte verstärkt
reforzada con un tejido de fibra de vidrio

5,5mm

spessore
thickness
épaisseur
stärke
espesor

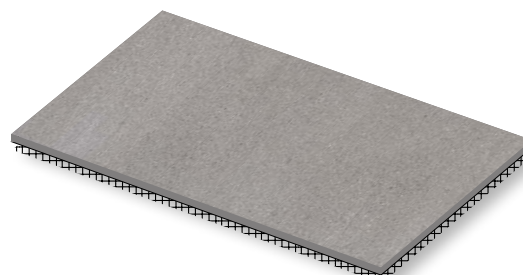

• **GRES LAMINATO UGL**

Laminated porcelain UGL
Grès laminé UGL
Laminiertes Feinsteinzeug UGL
Gres laminado UGL

• **FORMATI / SIZES**

WOOD-STOCK

20x100cm - 20x150cm - 20x200cm - 33x300cm / 8"x39" - 8"x59" - 8"x79" - 13"x118"

TYPE-32

20x200cm / 8"x79"

GOUACHE.10 - BASALTINA STONE PROJECT - SHADE - ARENARIA - RE-evolution

100x300cm / 39"x118"
50x50cm - 50x100cm - 100x100cm / 19^{1/2}"x19^{1/2}" - 19^{1/2}"x39" - 39x39"
4,9x100cm / 2"x39"

WAVES - LINES

100x300cm / 39"x118"

MAUK

spina 8,7x13,5x25,8cm / 3^{3/8}"x5^{5/16}"x10^{1/8}"
esa 38,3cm / 15^{1/8}"
cuadra 57,6cm / 22^{5/8}"

• **STONALIZZAZIONE**

Shading
Denuançage
Spielfarbig
Grado de tonalización

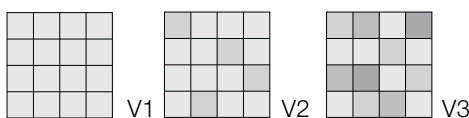

WAVES - LINES - SHADE V1
WOOD-STOCK - GOUACHE.10 - ARENARIA - RE-evolution V2
BASALTINA - MAUK V3

• **SPESSORE**

Thickness
Epaisseur
Stärke
Espesor

WOOD-STOCK 5,5 mm

TYPE-32 5,5 mm

WAVES - LINES 3,5 mm

GOUACHE.10 3 mm / 3,5 mm

BASALTINA 3 mm / 3,5 mm

MAUK 3 mm / 3,5 mm

SHADE 3 mm / 3,5 mm

ARENARIA 3 mm / 3,5 mm

RE-evolution 3 mm / 3,5 mm

• **FUGA MINIMA CONSIGLIATA PER POSA IN INTERNO**

Minimum suggested joint for indoor installation
Joint minimum conseillé pour pose en enterieure
Empfohlene Fugenbreite fuer Innenbereich
Junta mínima aconsejada para colocación en interior

Parete / Wall / Mur / Wand / Revestimiento
1 mm→slimtech 3mm - slimtech 3plus - slimtech 5plus

Pavimento / Floor / Sol / Boden / Pavimento
2 mm→slimtech 3plus - slimtech 5plus

SLIMTECH

ITA

ENG

SLIMTECH
5plus



Il nuovo traguardo della lastra oversize.

Slimtech 5Plus nasce a completamento del progetto Gres Laminato di Lea Ceramiche.

Lo spessore di 5,5mm apre a nuove performance tecniche e sorprendenti finiture superficiali.

Amplia le applicazioni e le destinazioni d'uso, ideale per ambienti heavy traffic.

Oversize slab's new goal.

Slimtech 5Plus is born to complete Lea Ceramiche's laminated porcelain project.

5,5 mm thickness opens up to new technical performances and surprising surface finishes.

Widens both applications and usage destinations, ideal for heavy traffic environments.

SLIMTECH

DESTINAZIONI D'USO

INTENDED USES



POSA A PAVIMENTO

Situazioni applicative sia per interventi di nuova costruzione che di ristrutturazioni con posa in sovrapposizione a pavimenti preesistenti.

RESIDENZIALE (CUCINE, BAGNI, LIVING, AREE COMUNI CONDOMINIALI, ED OGNI ALTRO AMBIENTE DI USO RESIDENZIALE).

slimtech 3plus - slimtech 5plus



IN INTERNO

COMMERCIALE LEGGERO (UFFICI, UFFICI APERTI AL PUBBLICO, SALE D'ATTESA, NEGOZI, BAGNI, SALE DI RISTORANTI, AUTOSALONI, BAR, CINEMA, AMBULATORI/CLINICHE).

slimtech 3plus - slimtech 5plus

COMMERCIALE INTENSIVO (*) (AREE COMUNI DI CENTRI COMMERCIALI, HALL DI ALBERGHI, MENSE, FAST FOOD, DISCOTEQUE, OSPEDALI).

slimtech 5plus



IN ESTERNO

A condizione che le superfici siano coperte (es. logge, balconi coperti, ecc.) e perfettamente impermeabilizzate. Si consiglia l'utilizzo di formati non superiori a 50x50cm.

slimtech 3plus - slimtech 5plus

* AD ESCLUSIONE DI ZONE SOTTOPOSTE AL PASSAGGIO DI CARICHI PESANTI CONCENTRATI (AD ES. CARRELLI A RUOTE DURE).

FLOOR INSTALLATION

For new buildings and refurbishing, for installation on existing floors.

RESIDENTIAL (KITCHENS, BATHROOMS, LIVING ROOMS, COMMON APARTMENT BLOCK AREAS AND ANY OTHER RESIDENTIAL ENVIRONMENT).

slimtech 3plus - slimtech 5plus

INTERIORS

LIGHT COMMERCIAL (OFFICES, OFFICES OPEN TO THE GENERAL PUBLIC, WAITING ROOMS, SHOPS, BATHROOMS, RESTAURANT DINING ROOMS, CAR SHOWROOMS, BARS, CINEMAS, SURGERIES/CLINICS).

slimtech 3plus - slimtech 5plus

HEAVY DUTY COMMERCIAL (*) (PUBLIC AREAS OF SHOPPING CENTRES, HOTEL HALLS, CANTEENS, FAST FOOD RESTAURANTS, CLUBS, HOSPITALS).

slimtech 5plus

EXTERIORS

Upon condition that surfaces are sheltered (e.g. loggias, covered balconies, etc.) and made totally impervious. The use of sizes that are not larger than 50x50cm is recommended.

slimtech 3plus - slimtech 5plus

* IN ANY SITUATION WITH THE EXCEPTION OF AREAS SUBJECT TO HEAVY LOADS (E.G. TROLLEYS WITH HARD WHEELS).



POSA A PARETE

Situazioni applicative sia per interventi di nuova costruzione che di ristrutturazioni con posa in sovrapposizione a rivestimenti preesistenti.



IN INTERNO

Qualunque ambiente residenziale e commerciale.

slimtech 3mm - slimtech 3plus - slimtech 5plus



IN ESTERNO

In situazioni dove non si devono praticare tagli ad angolo e con formati di lato non superiore ai 100 cm.

slimtech 3mm

In situazioni dove si devono praticare tagli angolari ed utilizzare grandi formati.

slimtech 3plus - slimtech 5plus

WALL INSTALLATION

For new buildings and refurbishing, for installation on existing walls.

Any residential and commercial environment.

slimtech 3mm - slimtech 3plus - slimtech 5plus

INTERIORS

In situations where corner cuts are not necessary and with sizes up to 100 cm.

slimtech 3mm

EXTERIORS

In situations where corner cuts and large sizes are necessary.

slimtech 3plus - slimtech 5plus



DESTINAZIONI SPECIALI

Facciate ventilate, rivestimenti termici a cappotto, rivestimento vasche e piscine, superfici da rivestire nel settore dell'arredamento.

In funzione delle specifiche del progetto e in abbinamento a sistemi costruttivi indicati da panariagroup e approvati dalla direzione lavori.

slimtech 3mm - slimtech 3plus - slimtech 5plus

SPECIAL USES

Ventilated facades, thermal insulation cladding systems, tiling for swimming pools, for furniture surfaces.

Depending on project specifications and in combination with the construction systems recommended by panariagroup and approved by the installation supervisor.

slimtech 3mm - slimtech 3plus - slimtech 5plus

FRA

DEU

ESP

La nouvelle frontière de la dalle "oversize".

Slimtech 5plus complète encore plus le projet Grès laminé de LEA Ceramiche.

L'épaisseur de 5,5 mm ouvre à nouvelles performances techniques et à exceptionnelles finitions de surface.

Augmente les possibilités d'application et utilisation, idéal pour le «trafic intensif».

Das neue Ziel in Großformatigen Platten.

Slimtech 5Plus, ist als Ergänzung von Laminierter feinsteinzeug Projects von Lea Ceramiche geboren.

Die 5,5 Starke eröffnet neue Möglichkeiten in technische Bereich, und überraschend oberflächen Optik.

Erweiterte Anwendungen. Ideal für hoher Gehfrequenz.

El nuevo objetivo de la placa de gran tamaño.

Slimtech 5Plus nació en la finalización de el proyecto de Porcelánico Laminado por Lea Ceramiche.

El grosor de 5,5 mm abre nuevas técnicas de interpretación y acabados sorprendentes.

Actualiza aplicaciones y usos, ideal para entornos de tráfico pesado.

DESTINATIONS D'USAGE

POSE AU SOL

Application aussi bien dans le cadre de nouveaux bâtiments que de rénovations avec pose sur un support existant.

RÉSIDENTIEL (CUISINES, SALLES DE BAIN, LIVING, PARTIES COMMUNES, TOUT AUTRE UTILISATION DANS LE CADRE RÉSIDENTIEL).

slimtech 3plus - slimtech 5plus

A L'INTÉRIEUR

COMMERCIAL MODÉRÉ (BUREAUX, BUREAUX OUVERTS AU PUBLIC, SALLES D'ATTENTE, MAGASINS, TOILETTES, SALLES DE RESTAURANT, GARAGES, CAFÉS, CINÉMAS, CABINETS MÉDICAUX, CLINIQUES).

slimtech 3plus - slimtech 5plus

COMMERCIAL INTENSIF (*) (PARTIES COMMUNES DE CENTRES COMMERCIAUX, RÉCEPTIONS D'HÔTELS, CANTINES, FAST FOOD, DISCOTHÈQUES, HÔPITAUX).

slimtech 5plus

A L'EXTÉRIEUR

À condition que le sol soit couvert (par ex. Loges, terrasses couvertes, etc.) et parfaitement imperméabilisé. On conseille l'utilisation du format 50x50.

slimtech 3plus - slimtech 5plus

* À L'EXCLUSION D'ENDROITS SOUMIS AU PASSAGE DE CHARGES LOURDES CONCENTRÉES (PAR EX. CHARIOTS AVEC PNEUS DURS, FENWICKS).

ANWENDUNGEN

FUBBODENVERLEGUNG

Zum Verlegen auf alten Fußbodenflächen oder auf neuem Estrich.

WOHNBEREICH (KÜCHEN, BAD, WOHNZIMMERN, ÖFFENTLICHEN BEREICHEN EIGENTUMSWOHNUNG, UND ALLEM ANDERE WOHNBEREICH).

slimtech 3plus - slimtech 5plus

INNENBEREICH

LEICHTE KOMMERZIELLE (BÜROS, ÖFFENTLICHEN BÜROS, WARTERÄUME, GESCHÄFTE, BÄDER, ZIMMER, RESTAURANTS, AUSSTELLUNGSRÄUME, BARS, KINOS, PRAXEN / KLINIKEN).

slimtech 3plus - slimtech 5plus

SCHWER KOMMERZIELLE (*) (ÖFFENTLICHEN BEREICHEN VON EINKAUFSZENTREN, HOTEL HALLS, CAFÉS, FAST-FOOD, DISKOS, KRANKENHÄUSER).

slimtech 5plus

AUSSENBEREICH

Vorausgesetzt, daß die Flächen abgedeckt sind (ZB: Halle, Dachten Terrassen Etc) und perfekt abgedichtet.

slimtech 3plus - slimtech 5plus

* AUSGENOMMEN BEREICHE MIT SCHWER UND KONZENTRIERT VERKEHR (ZB. WAGEN MIT HARTEN RÄDER).

USOS

COLOCACIÓN EN SUELOS

Situaciones de aplicación para trabajos en obras nuevas y para reestructuraciones con colocación sobre pavimentos existente.

RÉSIDENTIAL (COCINAS, CUARTOS DE BAÑO, LIVING, ÁREAS COMUNITARIAS COMUNES Y CUALQUIER OTRO ENTORNO DE USO RESIDENCIAL).

slimtech 3plus - slimtech 5plus

EN INTERIORES

COMERCIAL LIGERO (OFICINAS, OFICINAS ABIERTAS AL PÚBLICO, SALAS DE ESPERA, TIENDAS, BAÑOS, SALAS DE RESTAURANTES, TIENDAS DE COCHES, BARES, CINES, CONSULTORIOS/CLÍNICAS).

slimtech 3plus - slimtech 5plus

COMERCIAL INTENSIVO (*) (ÁREAS COMUNES DE CENTROS COMERCIALES, HALL DE HOTELES, COMEDORES COLECTIVOS, FAST FOOD, DISCOTECAS, HOSPITALES).

slimtech 5plus

EN EXTERIORES

Siempre que las superficies estén cubiertas (ej. galerías, balcones cubiertos, etc.) y perfectamente impermeabilizadas. Se aconseja utilizar formatos no superiores a 50x50 cm.

slimtech 3plus - slimtech 5plus

* EXCLUIDAS LAS ZONAS CON TRÁNSITO DE CARGAS PESADAS CONCENTRADAS (POR EJ. CARRETTILLAS CON RUEDAS DURAS).

POSE MURALE

Aussi bien dans de nouveaux bâtiments qu'en cas de rénovation avec pose sur un revêtement mural existant.

N'importe quel cadre résidentiel et commercial.

slimtech 3mm - slimtech 3plus - slimtech 5plus

A L'INTÉRIEUR

Dans les situations où on ne doit pas pratiquer une coupe à angle et utiliser un format dont le côté ne dépasse pas les 100 cm.

slimtech 3mm

A L'EXTÉRIEUR

Dans les cas où on doit effectuer une coupe à angle et utiliser de grands formats.

slimtech 3plus - slimtech 5plus

WANDVELEGUNG

Zum Verlegen auf alten neuem Wandflächen.

Jeder Kommerzielle und Wohnbereich.

slimtech 3mm - slimtech 3plus - slimtech 5plus

INNENBEREICH

In Fällen wo muss man, ohne winkeln und mit formaten nicht grosser als 100 cm pro seite arbeiten.

slimtech 3mm

AUSSENBEREICH

In Fällen wo muss man Winkeln scheniden und grossformaten benutzen.

slimtech 3plus - slimtech 5plus

COLOCACIÓN EN PAREDES

Situaciones de aplicación para trabajos en obras nuevas y para reestructuraciones con colocación sobre revestimientos existentes.

Cualquier entorno residencial y comercial.

slimtech 3mm - slimtech 3plus - slimtech 5plus

EN INTERIORES

En situaciones donde no se deben realizar cortes en ángulo y con formatos con un lado no superior a 100 cm.

slimtech 3mm

EN EXTERIORES

En situaciones donde se deben realizar cortes en ángulo y utilizar formatos grandes.

slimtech 3plus - slimtech 5plus

UTILISATIONS SPECIALES

Façades bardées, habillage de l'isolant thermique en façade, revêtement intérieur de spa et piscines, utilisations multiples dans l'ameublement.

En fonction des caractéristiques du projet et en mariage avec de systèmes constructifs indiqués par le groupe Panaria et approuvés par la direction des travaux.

slimtech 3mm - slimtech 3plus - slimtech 5plus

BESONDERE ANWENDUNGEN

Hinterlüftete Fassaden, Thermische Mantel Fassade, Becken Schwimmbäder, Möbelbereich.

Abhängig von den Projekts Spezifikationen, und in Verbindung mit Panariagroup Bausysteme, und Genehmigung der Bauleitung.

slimtech 3mm - slimtech 3plus - slimtech 5plus

USOS PREVISTOS ESPECIALES











Fachadas ventiladas, revestimientos de aislamiento térmico por el exterior, revestimiento de bañeras y piscinas, superficies para revestir en el sector de la decoración.

En función de las especificaciones del proyecto y en combinación con sistemas de construcción indicados por panariagroup y aprobados por la dirección de obras.

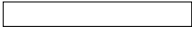
slimtech 3mm - slimtech 3plus - slimtech 5plus

WOOD-STOCK Microban®

protezione antibatterica

	Snow Wood	
		20x100cm/8"x39" slimtech 5plus
	Cream Wood	
	Nut Wood	
		20x150cm/8"x59" slimtech 5plus
	Honey Wood	
		20x200cm/8"x79" slimtech 5plus
	Vintage Wood	
	Coffee Wood	
		33x300cm/13"x118" slimtech 5plus

Imballi pag. 436
Packing
Emballage
Verpackung
Embalajes

GRES LAMINATO UGL

Laminated porcelain UGL
Grès laminé UGL
Laminiertes Feinsteinzeug UGL
Gres laminado UGL

SPESSORE

Thickness
Epaisseur
Stärke
Espesor

5,5 mm → slimtech 5plus

STONALIZZAZIONE

Shading
Denuançage
Spielfarbig
Grado de tonalización

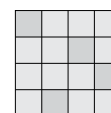

V2

FUGA MINIMA CONSIGLIATA PER POSA IN INTERNO

Minimum suggested joint for indoor fixing
Joint minimum conseillé pour pose en enterieure
Empfohlene Fugenbreite fuer Innenbereich
Junta mínima aconsejada para colocación en interior

Parete / Wall / Mur / Wand / Revestimiento
1 mm → slimtech 5plus

Pavimento / Floor / Sol / Boden / Pavimento
2 mm → slimtech 5plus

COEFFICIENTE DI ATTRITO DINAMICO B.C.R. TORTUS

$\mu > 0,40$

COEFFICIENT OF FRICTION ASTM C1028

dry - COF ≥ 0.60
wet - COF ≥ 0.60

RESISTENZA ALLO SCIVOLAMENTO DIN 51130

Slip resistance
Résistance au glissement
Rutschfestigkeit
Resistencia antideslizante

R10

DYNAMIC COEFFICIENT OF FRICTION BOT 3000

DCOF ≥ 0.42

ANTIBACTERIAL





wood-stock snow wood 20x200cm / 8"x79"



wood-stock cream wood 20x100cm / 8"x39"



wood-stock nut wood 20x200cm / 8"x79"



wood-stock coffee wood 20x200cm / 8"x79" - type-32 snow δ W 25 20x200cm / 8"x79"



wood-stock vintage wood 20x200cm / 8"x79"

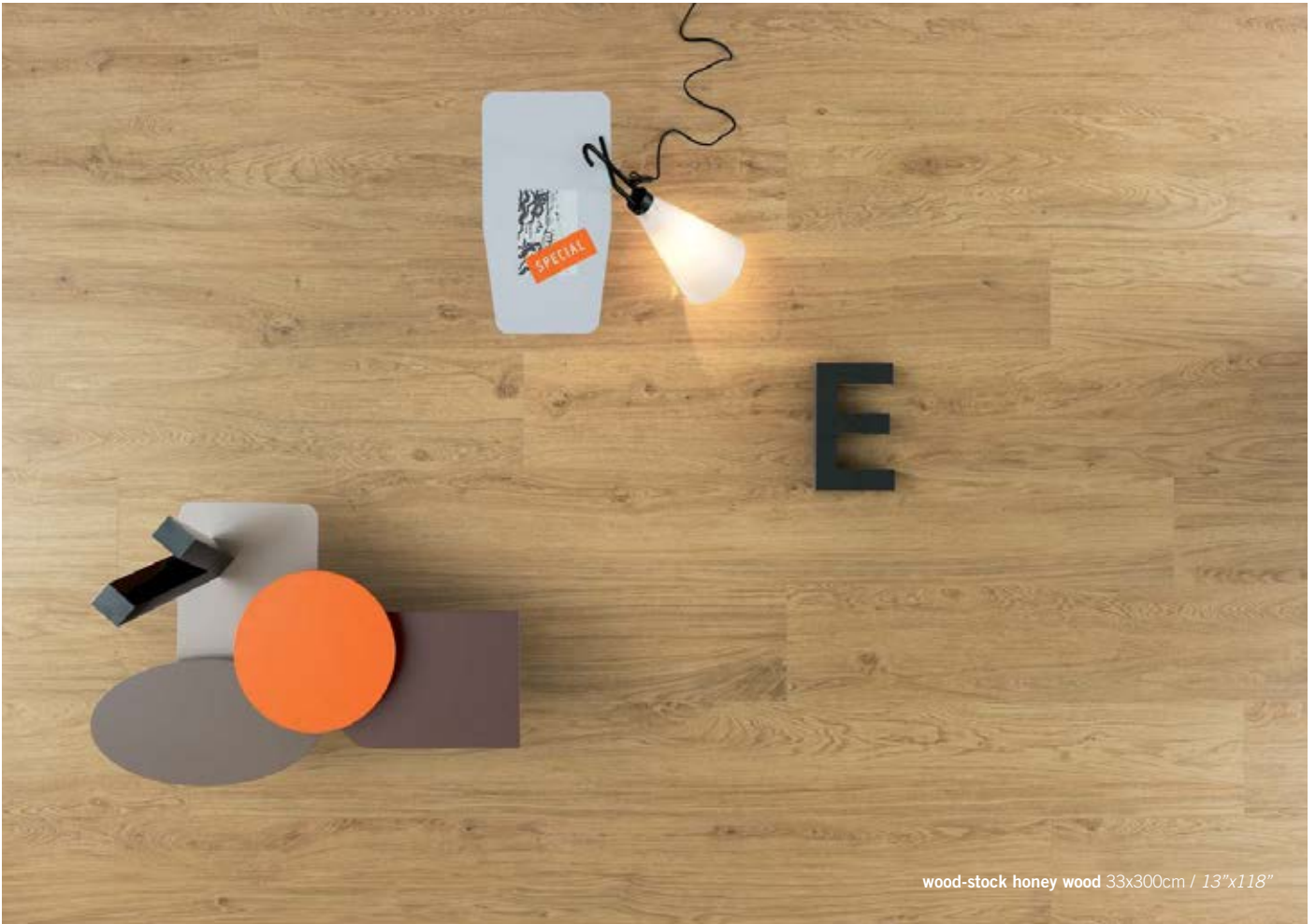

wood-stock honey wood 33x300cm / 13"x118"

Wood-stock Slimtech formati e colori

sizes and colors / formats et couleurs / formaten und farben / formatos y colores

snow wood



*33x300cm / 13"x118"
slimtech 5plus LS8WS45 2035

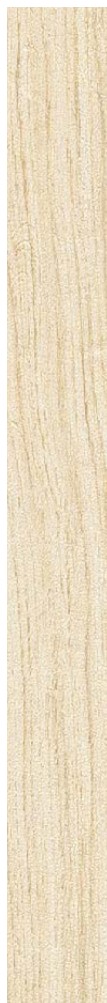

20x200cm / 8"x79"
slimtech 5plus LSJWS45 2015



20x150cm / 8"x59"
slimtech 5plus LSRWS45 2005



20x100cm / 8"x39"
slimtech 5plus LS0WS45 1915

*per ordini inferiori alle 15 lastre sarà addebitato il costo del pallet a Euro 80,00 netto. - the cost of the pallet, Euro 80,00 net, will be charged for orders less than 15 slabs. - pour toutes commandes inférieures à 15 dalles, un cout de 80 Euro correspondant au cout de la palette sera ajouté. - bei Abnahme einer Menge unter 15 Platten werden Euro 80,00 Netto für Verpackung/palette belastet. - Por pedidos inferiores a las 15 piezas adeudaremos el coste del palet de 80 Euro neto.

cream wood



*33x300cm / 13"x118"
slimtech 5plus LS8WS05 2035

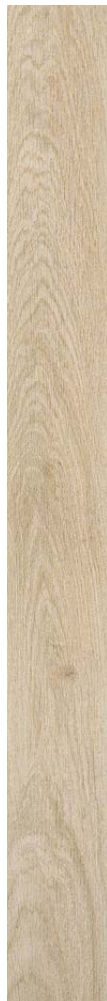

20x200cm / 8"x79"
slimtech 5plus LSJWS05 2015



20x150cm / 8"x59"
slimtech 5plus LSRWS05 2005



20x100cm / 8"x39"
slimtech 5plus LS0WS05 1915

Wood-stock Slimtech formati e colori

sizes and colors / formats et couleurs / formaten und farben / formatos y colores

nut wood



*33x300cm / 13"x118"
slimtech 5plus LS8WS55 2035



20x200cm / 8"x79"
slimtech 5plus LSJWS55 2015



20x150cm / 8"x59"
slimtech 5plus LSRWS55 2005



20x100cm / 8"x39"
slimtech 5plus LS0WS55 1915

*per ordini inferiori alle 15 lastre sarà addebitato il costo del pallet a Euro 80,00 netto. - the cost of the pallet, Euro 80,00 net, will be charged for orders less than 15 slabs. - pour toutes commandes inférieures à 15 dalles, un cout de 80 Euro correspondant au cout de la palette sera ajouté. - bei Abnahme einer Menge unter 15 Platten werden Euro 80,00 Netto für Verpackung/palette belastet. - Por pedidos inferiores a las 15 piezas adeudaremos el coste del palet de 80 Euro neto.

honey wood



*33x300cm / 13"x118"
slimtech 5plus LS8WS15 2035



20x200cm / 8"x79"
slimtech 5plus LSJWS15 2015



20x150cm / 8"x59"
slimtech 5plus LSRWS15 2005



20x100cm / 8"x39"
slimtech 5plus LS0WS15 1915

Wood-stock Slimtech formati e colori

sizes and colors / formats et couleurs / formaten und farben / formatos y colores

vintage wood



*33x300cm / 13"x118"
slimtech 5plus LS8WS25 2035



20x200cm / 8"x79"
slimtech 5plus LSJWS25 2015



20x150cm / 8"x59"
slimtech 5plus LSRWS25 2005



20x100cm / 8"x39"
slimtech 5plus LS0WS25 1915

*per ordini inferiori alle 15 lastre sarà addebitato il costo del pallet a Euro 80,00 netto. - the cost of the pallet, Euro 80,00 net, will be charged for orders less than 15 slabs. - pour toutes commandes inférieures à 15 dalles, un cout de 80 Euro correspondant au cout de la palette sera ajouté. - bei Abnahme einer Menge unter 15 Platten werden Euro 80,00 Netto für Verpackung/palette belastet. - Por pedidos inferiores a las 15 piezas adeudaremos el coste del palet de 80 Euro neto.

coffee wood



*33x300cm / 13"x118"
slimtech 5plus LS8WS35 2035



20x200cm / 8"x79"
slimtech 5plus LSJWS35 2015



20x150cm / 8"x59"
slimtech 5plus LSRWS35 2005



20x100cm / 8"x39"
slimtech 5plus LS0WS35 1915

TYPE-32

design Diego Grandi

 Snow

 Honey

 Vintage

 Coffee



20x200cm/8"x79"
slimtech 5plus

Imballi pag. 436
Packing
Emballage
Verpackung
Embalajes

GRES LAMINATO UGL

Laminated porcelain UGL
Grès laminé UGL
Laminiertes Feinsteinzeug UGL
Gres laminado UGL

SPESSORE

Thickness
Epaisseur
Stärke
Espesor
5,5 mm → slimtech 5plus

STONALIZZAZIONE

Shading
Denuançage
Spielfarbig
Grado de tonalización

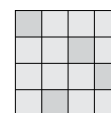

V2

FUGA MINIMA CONSIGLIATA PER POSA IN INTERNO

Minimum suggested joint for indoor fixing
Joint minimum conseillé pour pose en intérieure
Empfohlene Fugenbreite fuer Innenbereich
Junta mínima aconsejada para colocación en interior

Parete / Wall / Mur / Wand / Revestimiento
1 mm → slimtech 5plus

Pavimento / Floor / Sol / Boden / Pavimento
1 mm → slimtech 5plus

COEFFICIENTE DI ATTRITO DINAMICO B.C.R. TORTUS

$\mu > 0,40$

RESISTENZA ALLO SCIVOLAMENTO DIN 51130

Slip resistance
Résistance au glissement
Rutschfestigkeit
Resistencia antideslizante

R10

COEFFICIENT OF FRICTION ASTM C1028

dry - COF ≥ 0.60
wet - COF ≥ 0.60

DYNAMIC COEFFICIENT OF FRICTION BOT 3000

DCOF ≥ 0.42



type-32 Slimtech formati e colori

sizes and colors / formats et couleurs / formaten und farben / formatos y colores

snow



alfa snow warm 04
20x200cm / 8"x79"
slimtech 5plus

LSJTY04 [1995](#)



beta snow warm 12
20x200cm / 8"x79"
slimtech 5plus

LSJTY12 [1995](#)



gamma snow warm 20
20x200cm / 8"x79"
slimtech 5plus

LSJTY20 [1995](#)



delta snow warm 28
20x200cm / 8"x79"
slimtech 5plus

LSJTY28 [1995](#)



alfa snow cold 05
20x200cm / 8"x79"
slimtech 5plus

LSJTY05 [1995](#)



beta snow cold 13
20x200cm / 8"x79"
slimtech 5plus

LSJTY13 [1995](#)



gamma snow cold 21
20x200cm / 8"x79"
slimtech 5plus

LSJTY21 [1995](#)



delta snow cold 29
20x200cm / 8"x79"
slimtech 5plus

LSJTY29 [1995](#)

honey



alfa honey warm 03
20x200cm / 8"x79"
slimtech 5plus

LSJTY03 [1995](#)



beta honey warm 11
20x200cm / 8"x79"
slimtech 5plus

LSJTY11 [1995](#)



gamma honey warm 19
20x200cm / 8"x79"
slimtech 5plus

LSJTY19 [1995](#)



delta honey warm 27
20x200cm / 8"x79"
slimtech 5plus

LSJTY27 [1995](#)



alfa honey cold 06
20x200cm / 8"x79"
slimtech 5plus

LSJTY06 [1995](#)



beta honey cold 14
20x200cm / 8"x79"
slimtech 5plus

LSJTY14 [1995](#)



gamma honey cold 22
20x200cm / 8"x79"
slimtech 5plus

LSJTY22 [1995](#)



delta honey cold 30
20x200cm / 8"x79"
slimtech 5plus

LSJTY30 [1995](#)

type-32 Slimtech formati e colori

sizes and colors / formats et couleurs / formaten und farben / formatos y colores

vintage



alfa vintage warm 02
20x200cm / 8"x79"
slimtech 5plus

LSJTY02 [1995](#)



beta vintage warm 10
20x200cm / 8"x79"
slimtech 5plus

LSJTY10 [1995](#)



gamma vintage warm 18
20x200cm / 8"x79"
slimtech 5plus

LSJTY18 [1995](#)



delta vintage warm 26
20x200cm / 8"x79"
slimtech 5plus

LSJTY26 [1995](#)

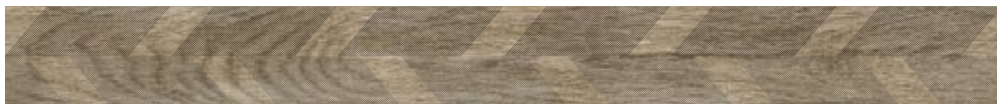

alfa vintage cold 07
20x200cm / 8"x79"
slimtech 5plus

LSJTY07 [1995](#)



beta vintage cold 15
20x200cm / 8"x79"
slimtech 5plus

LSJTY15 [1995](#)



gamma vintage cold 23
20x200cm / 8"x79"
slimtech 5plus

LSJTY23 [1995](#)



delta vintage cold 31
20x200cm / 8"x79"
slimtech 5plus

LSJTY31 [1995](#)

coffee



alfa coffee warm 01
20x200cm / 8"x79"
slimtech 5plus

LSJTY01 [1995](#)

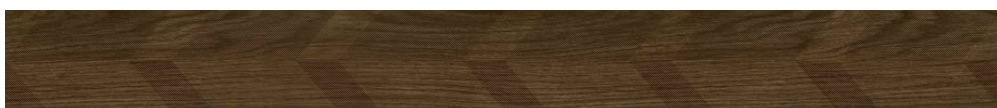

beta coffee warm 09
20x200cm / 8"x79"
slimtech 5plus

LSJTY09 [1995](#)



gamma coffee warm 17
20x200cm / 8"x79"
slimtech 5plus

LSJTY17 [1995](#)



delta coffee warm 25
20x200cm / 8"x79"
slimtech 5plus

LSJTY25 [1995](#)



alfa coffee cold 08
20x200cm / 8"x79"
slimtech 5plus

LSJTY08 [1995](#)



beta coffee cold 16
20x200cm / 8"x79"
slimtech 5plus

LSJTY16 [1995](#)



gamma coffee cold 24
20x200cm / 8"x79"
slimtech 5plus

LSJTY24 [1995](#)



delta coffee cold 32
20x200cm / 8"x79"
slimtech 5plus

LSJTY32 [1995](#)

RE-evolution

 SRW010

4,9x100cm/2"x39"
slimtech 3plus

 SRW020

 SRW030

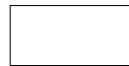

50x100cm/19 1/2"x39"
slimtech 3mm
slimtech 3plus



50x50cm/19 1/2"x19 1/2"
slimtech 3plus

 SRC010

 SRC020

 SRC030

100x100cm/39"x39"
slimtech 3plus

100x300cm/39"x118"
slimtech 3mm
slimtech 3plus

Imballi pag. 433
Packing
Emballage
Verpackung
Embalajes

GRES LAMINATO UGL

Laminated porcelain UGL
Grès laminé UGL
Laminiertes Feinsteinzeug UGL
Gres laminado UGL

SPESSORE

Thickness
Epaisseur
Stärke
Espesor

3 mm → slimtech 3mm
3,5 mm → slimtech 3plus

STONALIZZAZIONE

Shading
Denuançage
Spielfarbig
Grado de tonalización

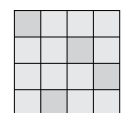

V2

FUGA MINIMA CONSIGLIATA PER POSA IN INTERNO

Minimum suggested joint for indoor fixing
Joint minimum conseillé pour pose en enterieure
Empfohlene Fugenbreite fuer Innenbereich
Junta mínima aconsejada para colocación en interior

Parete / Wall / Mur / Wand / Revestimiento
1 mm → slimtech 3mm - slimtech 3plus

Pavimento / Floor / Sol / Boden / Pavimento
2 mm → slimtech 3plus





RE-evolution SRC020 100x300cm / 39"x118" - RE-evolution SRW010 100x100cm / 39"x39"



RE-evolution SRC020 100x300cm / 39"x118"



RE-evolution SRW020 100x100cm / 39"x39"

RE-evolution Slimtech formati e colori

sizes and colors / formats et couleurs / formaten und farben / formatos y colores

SRW010



*100x300cm / 39"x118"
slimtech 3mm
slimtech 3plus

LSARE60 1755
LSARE65 1945



50x50cm / 19 1/2"x19 1/2"
slimtech 3plus LSDRE65 1945



50x100cm / 19 1/2"x39"
slimtech 3mm
slimtech 3plus

LSBRE60 1755
LSBRE65 1945



100x100cm / 39"x39"
slimtech 3plus

LSCRE65 1945



4,9x100cm / 2"x39"
slimtech 3plus LSERE65 2075

*per ordini inferiori alle 5 lastre sarà addebitato il costo del pallet a Euro 80,00 netto. - the cost of the pallet, Euro 80,00 net, will be charged for orders less than 5 slabs. - pour toutes commandes inférieures à 5 dalles, un cout de 80 Euro correspondant au cout de la palette sera ajouté. - bei Abnahme einer Menge unter 5 Platten werden Euro 80,00 Netto für Verpackung/palette belastet. - Por pedidos inferiores a las 5 piezas adeudaremos el coste del palet de 80 Euro neto.

SRW020



*100x300cm / 39"x118"
slimtech 3mm
slimtech 3plus

LSARE70 1755
LSARE75 1945



50x50cm / 19 1/2"x19 1/2"
slimtech 3plus LSDRE75 1945

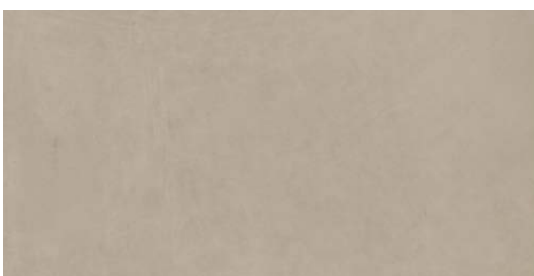

50x100cm / 19 1/2"x39"
slimtech 3mm
slimtech 3plus

LSBRE70 1755
LSBRE75 1945



100x100cm / 39"x39"
slimtech 3plus

LSCRE75 1945



4,9x100cm / 2"x39"
slimtech 3plus LSERE75 2075

RE-evolution Slimtech formati e colori

sizes and colors / formats et couleurs / formaten und farben / formatos y colores

SRW030



*100x300cm / 39"x118"
slimtech 3mm
slimtech 3plus

LSARE80 1755
LSARE85 1945



50x50cm / 19 1/2"x19 1/2"
slimtech 3plus LSDRE85 1945



50x100cm / 19 1/2"x39"
slimtech 3mm
slimtech 3plus

LSBRE80 1755
LSBRE85 1945



100x100cm / 39"x39"
slimtech 3plus

LSCRE85 1945



4,9x100cm / 2"x39"
slimtech 3plus LSERE85 2075

*per ordini inferiori alle 5 lastre sarà addebitato il costo del pallet a Euro 80,00 netto. - the cost of the pallet, Euro 80,00 net, will be charged for orders less than 5 slabs. - pour toutes commandes inférieures à 5 dalles, un cout de 80 Euro correspondant au cout de la palette sera ajouté. - bei Abnahme einer Menge unter 5 Platten werden Euro 80,00 Netto für Verpackung/palette belastet. - Por pedidos inferiores a las 5 piezas adeudaremos el coste del palet de 80 Euro neto.

SRC010



50x50cm / 19¹/₂"x19¹/₂"
slimtech 3plus LSDRE15 1945

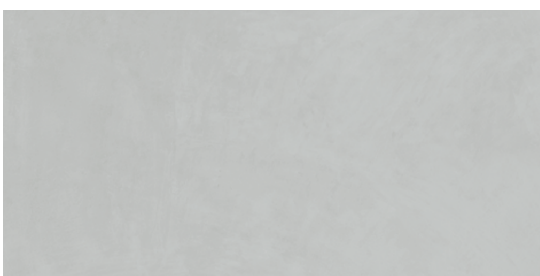

50x100cm / 19¹/₂"x39"
slimtech 3mm LSBRE10 1755
slimtech 3plus LSBRE15 1945



100x100cm / 39"x39"
slimtech 3plus LSCRE15 1945



4,9x100cm / 2"x39"
slimtech 3plus LSERE15 2075

*100x300cm / 39"x118"
slimtech 3mm LSARE10 1755
slimtech 3plus LSARE15 1945

RE-evolution Slimtech formati e colori

sizes and colors / formats et couleurs / formaten und farben / formatos y colores

SRC020



*100x300cm / 39"x118"
slimtech 3mm
slimtech 3plus

LSARE20 1755
LSARE25 1945



50x50cm / 19 1/2"x19 1/2"
slimtech 3plus LSDRE25 1945

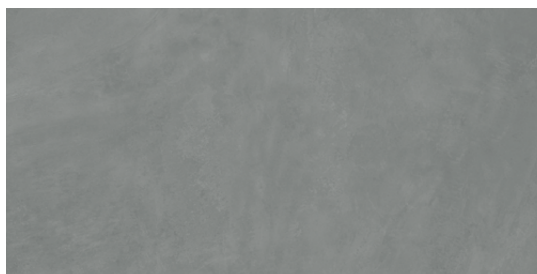

50x100cm / 19 1/2"x39"
slimtech 3mm
slimtech 3plus

LSBRE20 1755
LSBRE25 1945

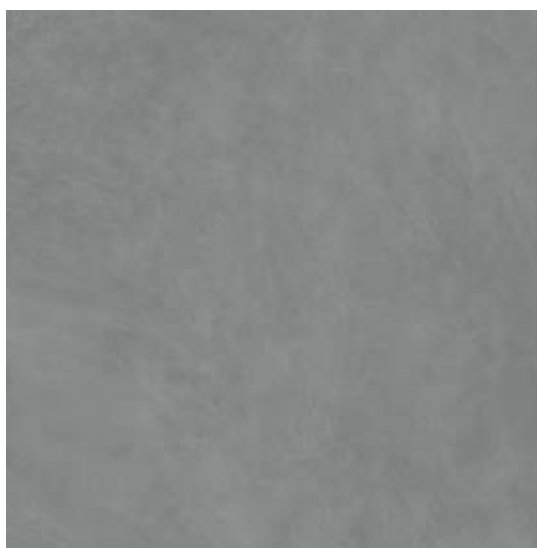

100x100cm / 39"x39"
slimtech 3plus

LSCRE25 1945



4,9x100cm / 2"x39"
slimtech 3plus LSERE25 2075

*per ordini inferiori alle 5 lastre sarà addebitato il costo del pallet a Euro 80,00 netto. - the cost of the pallet, Euro 80,00 net, will be charged for orders less than 5 slabs. - pour toutes commandes inférieures à 5 dalles, un cout de 80 Euro correspondant au cout de la palette sera ajouté. - bei Abnahme einer Menge unter 5 Platten werden Euro 80,00 Netto für Verpackung/palette belastet. - Por pedidos inferiores a las 5 piezas adeudaremos el coste del palet de 80 Euro neto.

SRC030



*100x300cm / 39"x118"
slimtech 3mm
slimtech 3plus

LSARE30 1755
LSARE35 1945



50x50cm / 19 1/2"x19 1/2"
slimtech 3plus LSDRE35 1945



50x100cm / 19 1/2"x39"
slimtech 3mm
slimtech 3plus

LSBRE30 1755
LSBRE35 1945



100x100cm / 39"x39"
slimtech 3plus

LSCRE35 1945



4,9x100cm / 2"x39"
slimtech 3plus LSERE35 2075

RE-evolution Slimtech corredi e pezzi speciali

trims and decors / articles et pièces spéciales

formstücke und dekore / decorados y piezas especiales



CORNICE
SRW010
5,5x50cm / 2 1/8"x19 1/2"

LG9RE60 [0435](#)



BATTISCOPIA
SRW010
12x50cm / 4 3/4"x19 1/2"

LG9REB6 [0615](#)



CORNICE
SRW020
5,5x50cm / 2 1/8"x19 1/2"

LG9RE70 [0435](#)



BATTISCOPIA
SRW020
12x50cm / 4 3/4"x19 1/2"

LG9REB7 [0615](#)



CORNICE
SRW030
5,5x50cm / 2 1/8"x19 1/2"

LG9RE80 [0435](#)

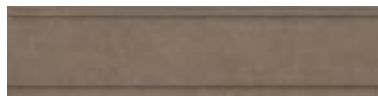

BATTISCOPIA
SRW030
12x50cm / 4 3/4"x19 1/2"

LG9REB8 [0615](#)



CORNICE
SRC010
5,5x50cm / 2 1/8"x19 1/2"

LG9RE10 [0435](#)



BATTISCOPIA
SRC010
12x50cm / 4 3/4"x19 1/2"

LG9REB1 [0615](#)



CORNICE
SRC020
5,5x50cm / 2 1/8"x19 1/2"

LG9RE20 [0435](#)



BATTISCOPIA
SRC020
12x50cm / 4 3/4"x19 1/2"

LG9REB2 [0615](#)



CORNICE
SRC030
5,5x50cm / 2 1/8"x19 1/2"

LG9RE30 [0435](#)



BATTISCOPIA
SRC030
12x50cm / 4 3/4"x19 1/2"

LG9REB3 [0615](#)



RE-evolution SRW010 4,9x100cm / 2"x39" - RE-evolution SRW030 4,9x100cm / 2"x39"
RE-evolution SRW010 100x100cm / 39"x39" - RE-evolution cornice SRW010 5,5x50cm / 2¹/₈"x19¹/₂"
RE-evolution battiscopa SRW010 12x50cm / 4³/₄"x19¹/₂"

GOUACHE.10

design Diego Grandi

 White Cloud

 Soft Sand

 Light Rock

 Black Stone

 Crystal Water

 Cool Rain

 Deep Sea

4,9x100cm/2"x39"
slimtech 3plus

50x100cm/19 1/2"x39"
slimtech 3mm
slimtech 3plus

100x100cm/39"x39"
slimtech 3plus

50x50cm/19 1/2"x19 1/2"
slimtech 3plus



100x300cm/39"x118"
slimtech 3mm
slimtech 3plus

Imballi pag. 429
Packing
Emballage
Verpackung
Embalajes

GRES LAMINATO UGL
Laminated porcelain UGL
Grès laminé UGL
Laminiertes Feinsteinzeug UGL
Gres laminado UGL

SPESORE
Thickness
Epaisseur
Stärke
Espesor
3 mm → slimtech 3mm
3,5 mm → slimtech 3plus

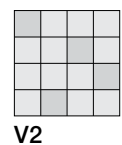
STONALIZZAZIONE
Shading
Denuançage
Spielfarbig
Grado de tonalización



FUGA MINIMA CONSIGLIATA PER POSA IN INTERNO
Minimum suggested joint for indoor fixing
Joint minimum conseillé pour pose en enterieure
Empfohlene Fugenbreite fuer Innenbereich
Junta mínima aconsejada para colocación en interior

Parete / Wall / Mur / Wand / Revestimiento
1 mm → slimtech 3mm - slimtech 3plus

Pavimento / Floor / Sol / Boden / Pavimento
2 mm → slimtech 3plus

RESISTENZA ALLO SCIVOLAMENTO DIN 51130

Slip resistance
Résistance au glissement
Rutschfestigkeit
Resistencia antideslizante
R9 (3plus)

COEFFICIENTE DI ATTRITO DINAMICO B.C.R. TORTUS
 $\mu > 0,40$ (3plus)

COEFFICIENT OF FRICTION ASTM C1028
dry - COF ≥ 0.60 (3plus)
wet - COF ≥ 0.60 (3plus)

DYNAMIC COEFFICIENT OF FRICTION BOT 3000
DCOF ≥ 0.42 (3plus)





gouache.10 crystal water 100x300cm / 39"x118" - **gouache.10 crystal water** 100x100cm / 39"x39"



gouache.10 deep sea 100x100cm / 39"x39" - *kensington plank lagoon 31x62 / 12¹/₄"x24¹/₂"*



gouache.10 crystal water 100x300cm / 39"x118"

Gouache.10 Slimtech formati e colori

sizes and colors / formats et couleurs / formaten und farben / formatos y colores

white cloud



*100x300cm / 39"x118"
slimtech 3mm
slimtech 3plus

LSAGU31 1560
LSAGU36 1810



50x50cm / 19 1/2"x19 1/2"
slimtech 3plus LSDGU35 1620



50x100cm / 19 1/2"x39"
slimtech 3mm
slimtech 3plus

LSBGU30 1400
LSBGU35 1620



100x100cm / 39"x39"
slimtech 3plus

LSCGU35 1750



4,9x100cm / 2"x39"
slimtech 3plus LSEGU35 1930

*per ordini inferiori alle 5 lastre sarà addebitato il costo del pallet a Euro 80,00 netto. - the cost of the pallet, Euro 80,00 net, will be charged for orders less than 5 slabs. - pour toutes commandes inférieures à 5 dalles, un cout de 80 Euro correspondant au cout de la palette sera ajouté. - bei Abnahme einer Menge unter 5 Platten werden Euro 80,00 Netto für Verpackung/palette belastet. - Por pedidos inferiores a las 5 piezas adeudaremos el coste del palet de 80 Euro neto.

soft sand



*100x300cm / 39"x118"
slimtech 3mm
slimtech 3plus

LSAGU21 1560
LSAGU26 1810



50x50cm / 19 1/2"x19 1/2"
slimtech 3plus LSDGU25 1620



50x100cm / 19 1/2"x39"
slimtech 3mm
slimtech 3plus

LSBGU20 1400
LSBGU25 1620



100x100cm / 39"x39"
slimtech 3plus

LSCGU25 1750



4,9x100cm / 2"x39"
slimtech 3plus LSEGU25 1930

Gouache.10 Slimtech formati e colori

sizes and colors / formats et couleurs / formaten und farben / formatos y colores

light rock



*100x300cm / 39"x118"
slimtech 3mm
slimtech 3plus

LSAGU11 1560
LSAGU16 1810



50x50cm / 19 1/2"x19 1/2"
slimtech 3plus LSDGU15 1620



50x100cm / 19 1/2"x39"
slimtech 3mm
slimtech 3plus

LSBGU10 1400
LSBGU15 1620



100x100cm / 39"x39"
slimtech 3plus

LSCGU15 1750



4,9x100cm / 2"x39"
slimtech 3plus LSEGU15 1930

*per ordini inferiori alle 5 lastre sarà addebitato il costo del pallet a Euro 80,00 netto. - the cost of the pallet, Euro 80,00 net, will be charged for orders less than 5 slabs. - pour toutes commandes inférieures à 5 dalles, un cout de 80 Euro correspondant au cout de la palette sera ajouté. - bei Abnahme einer Menge unter 5 Platten werden Euro 80,00 Netto für Verpackung/palette belastet. - Por pedidos inferiores a las 5 piezas adeudaremos el coste del palet de 80 Euro neto.

black stone

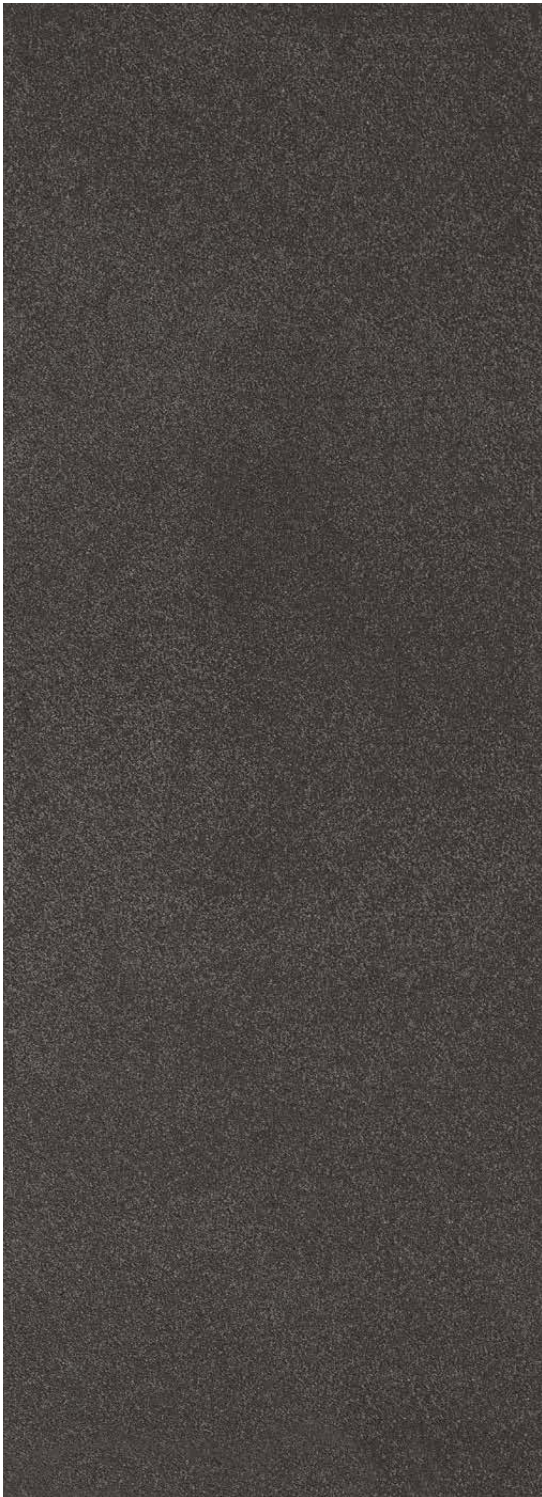

*100x300cm / 39"x118"
slimtech 3mm
slimtech 3plus

LSAGU01 1560
LSAGU06 1810

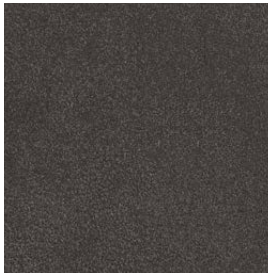

50x50cm / 19 1/2"x19 1/2"
slimtech 3plus LSDGU05 1620



50x100cm / 19 1/2"x39"
slimtech 3mm
slimtech 3plus

LSBGU00 1400
LSBGU05 1620



100x100cm / 39"x39"
slimtech 3plus

LSCGU05 1750



4,9x100cm / 2"x39"
slimtech 3plus LSEGU05 1930

Gouache.10 Slimtech formati e colori

sizes and colors / formats et couleurs / formaten und farben / formatos y colores

crystal water



*100x300cm / 39"x118"
slimtech 3mm
slimtech 3plus

LSAGU41 1560
LSAGU46 1810



50x50cm / 19 1/2"x19 1/2"
slimtech 3plus LSDGU45 1620



50x100cm / 19 1/2"x39"
slimtech 3mm
slimtech 3plus

LSBGU40 1400
LSBGU45 1620



100x100cm / 39"x39"
slimtech 3plus

LSCGU45 1750



4,9x100cm / 2"x39"
slimtech 3plus LSEGU45 1930

*per ordini inferiori alle 5 lastre sarà addebitato il costo del pallet a Euro 80,00 netto. - the cost of the pallet, Euro 80,00 net, will be charged for orders less than 5 slabs. - pour toutes commandes inférieures à 5 dalles, un cout de 80 Euro correspondant au cout de la palette sera ajouté. - bei Abnahme einer Menge unter 5 Platten werden Euro 80,00 Netto für Verpackung/palette belastet. - Por pedidos inferiores a las 5 piezas adeudaremos el coste del palet de 80 Euro neto.

cool rain

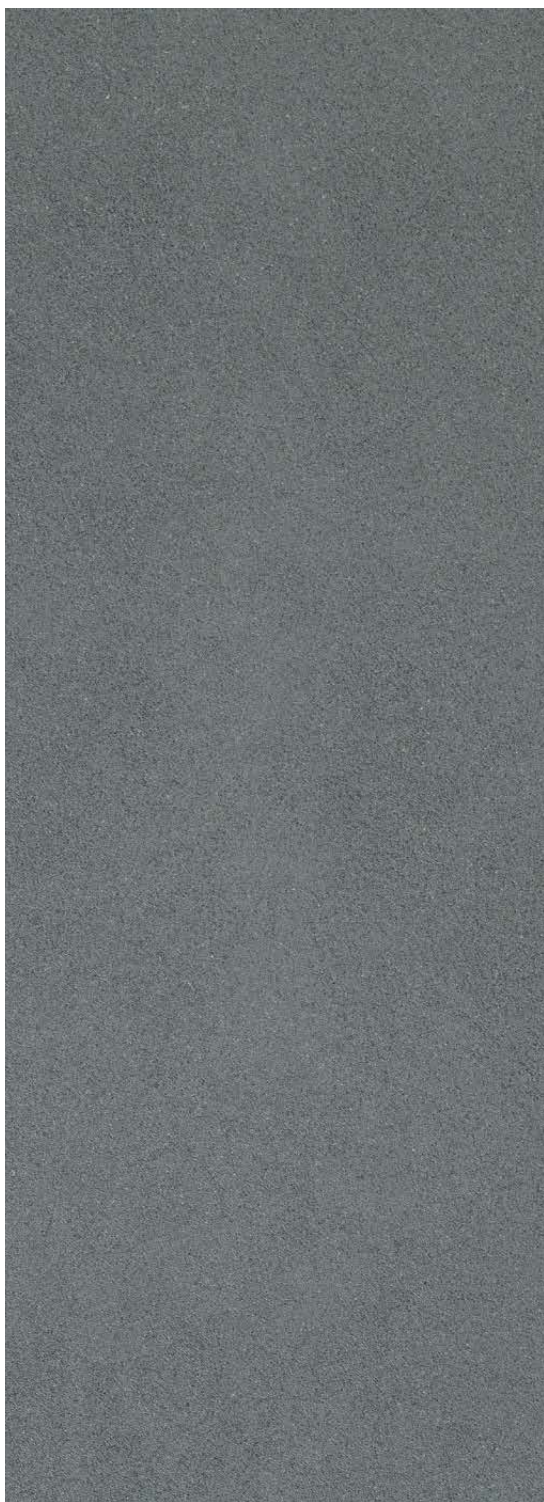

*100x300cm / 39"x118"
slimtech 3mm
slimtech 3plus

LSAGU51 1560
LSAGU56 1810



50x50cm / 19 1/2"x19 1/2"
slimtech 3plus LSDGU55 1620

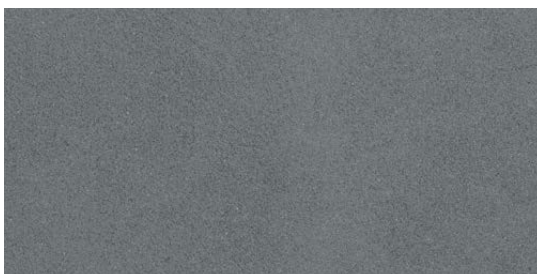

50x100cm / 19 1/2"x39"
slimtech 3mm
slimtech 3plus

LSBGU50 1400
LSBGU55 1620

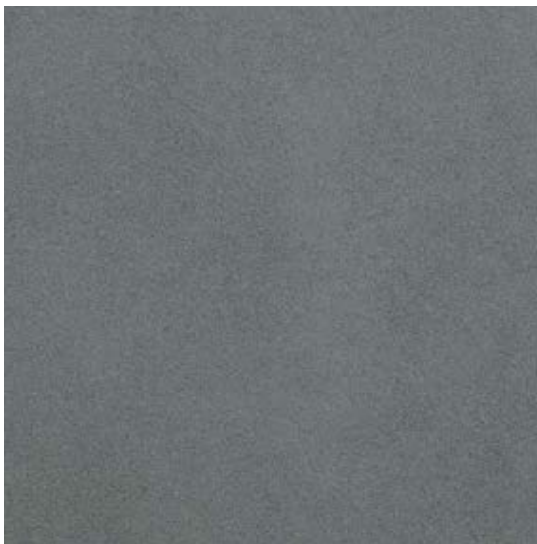

100x100cm / 39"x39"
slimtech 3plus

LSCGU55 1750



4,9x100cm / 2"x39"
slimtech 3plus LSEGU55 1930

Gouache.10 Slimtech formati e colori

sizes and colors / formats et couleurs / formaten und farben / formatos y colores

deep sea



*100x300cm / 39"x118"
slimtech 3mm
slimtech 3plus

LSAGU61 1560
LSAGU66 1810



50x50cm / 19 1/2"x19 1/2"
slimtech 3plus LSDGU65 1620



50x100cm / 19 1/2"x39"
slimtech 3mm
slimtech 3plus

LSBGU60 1400
LSBGU65 1620



100x100cm / 39"x39"
slimtech 3plus

LSCGU65 1750



4,9x100cm / 2"x39"
slimtech 3plus LSEGU65 1930

*per ordini inferiori alle 5 lastre sarà addebitato il costo del pallet a Euro 80,00 netto. - the cost of the pallet, Euro 80,00 net, will be charged for orders less than 5 slabs. - pour toutes commandes inférieures à 5 dalles, un cout de 80 Euro correspondant au cout de la palette sera ajouté. - bei Abnahme einer Menge unter 5 Platten werden Euro 80,00 Netto für Verpackung/palette belastet. - Por pedidos inferiores a las 5 piezas adeudaremos el coste del palet de 80 Euro neto.

Gouache.10 Slimtech decori

decors / decors / dekore / decoros

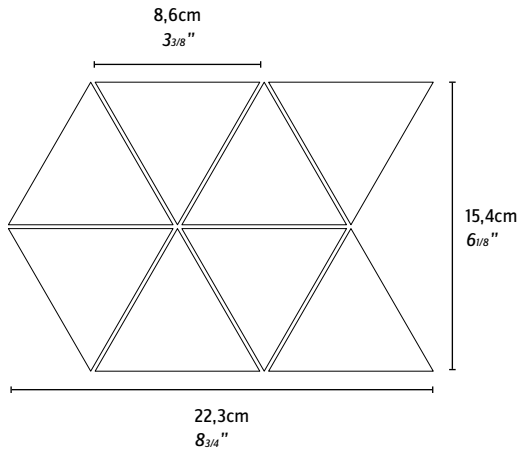

LIBECCIO
white cloud
15,4x22,3cm / 6 1/8"x8 3/4"
LS9GU03 [0330](#)

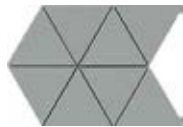

LIBECCIO
crystal water
15,4x22,3cm / 6 1/8"x8 3/4"
LS9GU02 [0330](#)



LIBECCIO 01
warm
15,4x22,3cm / 6 1/8"x8 3/4"
LS9GU08 [0330](#)



LIBECCIO 01
cold
15,4x22,3cm / 6 1/8"x8 3/4"
LS9GU07 [0330](#)



LIBECCIO
soft sand
15,4x22,3cm / 6 1/8"x8 3/4"
LS9GU04 [0330](#)



LIBECCIO
cool rain
15,4x22,3cm / 6 1/8"x8 3/4"
LS9GU00 [0330](#)



LIBECCIO 02
15,4x22,3cm / 6 1/8"x8 3/4"
LS9GU09 [0330](#)



LIBECCIO 03
15,4x22,3cm / 6 1/8"x8 3/4"
LS9GU10 [0330](#)



LIBECCIO
light rock
15,4x22,3cm / 6 1/8"x8 3/4"
LS9GU01 [0330](#)



LIBECCIO
deep sea
15,4x22,3cm / 6 1/8"x8 3/4"
LS9GU06 [0330](#)



LIBECCIO
black stone
15,4x22,3cm / 6 1/8"x8 3/4"
LS9GU05 [0330](#)



studies in gouache noire b black stone 50x100cm / 19.1/2"x39" - gouache.10 black stone 100x100cm / 39"x39"

STUDIES IN GOUACHE

design Diego Grandi

white cloud

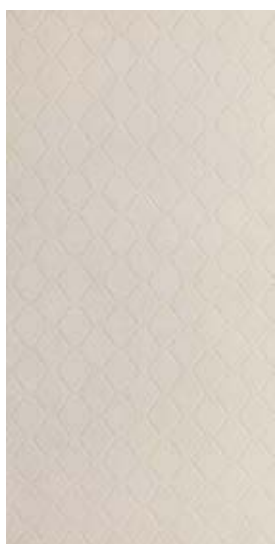

DECORO GRID
white cloud
50x100cm / 19 1/2" x 39"
slimtech 3plus LS9GUG3 2025



DECORO KNIT
white cloud
50x100cm / 19 1/2" x 39"
slimtech 3plus LS9GUK3 2025



DECORO MOIRE B
white cloud
50x100cm / 19 1/2" x 39"
slimtech 3plus LS9GUM3 2025

a



***DECORO SCRATCH**
white cloud
50x100cm / 19 1/2" x 39"
slimtech 3plus LS9GUS3 2115

b



c



a	b	c
a	b	c

Imballi pag. 434

Packing
Emballage
Verpackung
Embalajes

Studies in Gouache Slimtech formati e colori

sizes and colors / formats et couleurs / formaten und farben / formatos y colores

soft sand



DECORO GRID
soft sand
50x100cm / 19 1/2"x39"
slimtech 3plus LS9GUG2 2025



DECORO KNIT
soft sand
50x100cm / 19 1/2"x39"
slimtech 3plus LS9GUK2 2025



DECORO MOIRE B
soft sand
50x100cm / 19 1/2"x39"
slimtech 3plus LS9GUM2 2025

a



***DECORO SCRATCH**
soft sand
50x100cm / 19 1/2"x39"
slimtech 3plus LS9GUS2 2115

b



c



light rock



DECORO GRID
light rock
50x100cm / 19 1/2"x39"
slimtech 3plus LS9GUG1 2025



DECORO KNIT
light rock
50x100cm / 19 1/2"x39"
slimtech 3plus LS9GUK1 2025



DECORO MOIRE B
light rock
50x100cm / 19 1/2"x39"
slimtech 3plus LS9GUM1 2025

a



***DECORO SCRATCH**
light rock
50x100cm / 19 1/2"x39"
slimtech 3plus LS9GUS1 2115

b



c



a	b	c
a	b	c

Studies in Gouache Slimtech formati e colori

sizes and colors / formats et couleurs / formaten und farben / formatos y colores

black stone



DECORO GRID
black stone
50x100cm / 19 1/2"x39"
slimtech 3plus LS9GUG0 2025

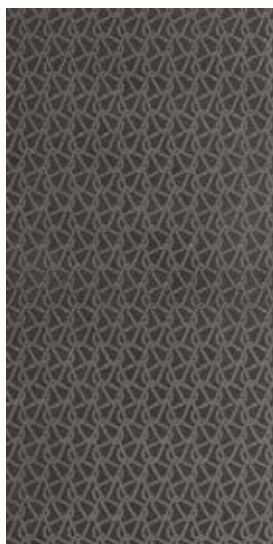

DECORO KNIT
black stone
50x100cm / 19 1/2"x39"
slimtech 3plus LS9GUK0 2025



DECORO MOIRE B
black stone
50x100cm / 19 1/2"x39"
slimtech 3plus LS9GUM0 2025

a



***DECORO SCRATCH**
black stone
50x100cm / 19 1/2"x39"
slimtech 3plus LS9GUS0 2115

b



c



crystal water



DECORO GRID
crystal water
50x100cm / 19 1/2"x39"
slimtech 3plus LS9GUG4 2025



DECORO KNIT
crystal water
50x100cm / 19 1/2"x39"
slimtech 3plus LS9GUK4 2025

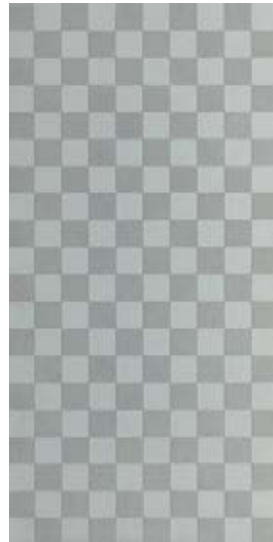

DECORO MOIRE B
crystal water
50x100cm / 19 1/2"x39"
slimtech 3plus LS9GUM4 2025

a



***DECORO SCRATCH**
crystal water
50x100cm / 19 1/2"x39"
slimtech 3plus LS9GUS4 2115

b



c



a	b	c
a	b	c

Studies in Gouache Slimtech formati e colori

sizes and colors / formats et couleurs / formaten und farben / formatos y colores

cool rain



DECORO GRID
cool rain
50x100cm / 19 1/2"x39"
slimtech 3plus LS9GUG5 2025

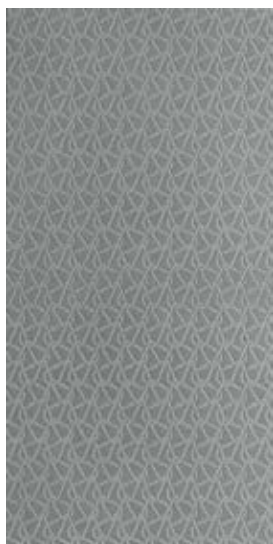

DECORO KNIT
cool rain
50x100cm / 19 1/2"x39"
slimtech 3plus LS9GUK5 2025

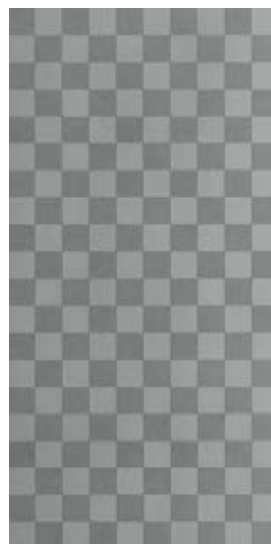

DECORO MOIRE B
cool rain
50x100cm / 19 1/2"x39"
slimtech 3plus LS9GUM5 2025

a

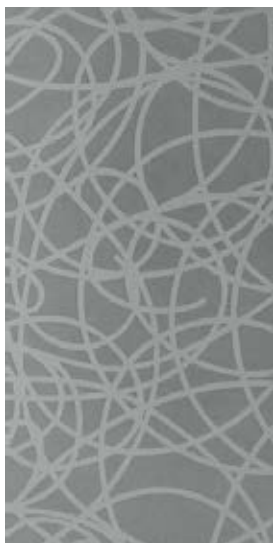

***DECORO SCRATCH**
cool rain
50x100cm / 19 1/2"x39"
slimtech 3plus LS9GUS5 2115

b



c



deep sea



DECORO GRID
 deep sea
 50x100cm / 19 1/2"x39"
 slimtech 3plus LS9GUG6 2025



DECORO KNIT
 deep sea
 50x100cm / 19 1/2"x39"
 slimtech 3plus LS9GUK6 2025

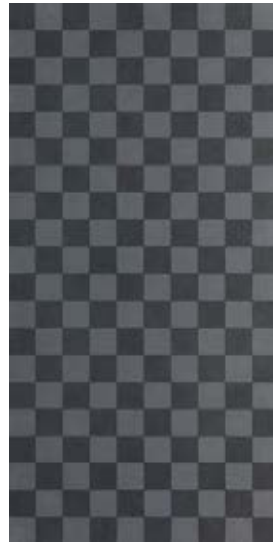

DECORO MOIRE B
 deep sea
 50x100cm / 19 1/2"x39"
 slimtech 3plus LS9GUM6 2025

a



***DECORO SCRATCH**
 deep sea
 50x100cm / 19 1/2"x39"
 slimtech 3plus LS9GUS6 2115

b



c



a	b	c
a	b	c



studies in gouache scratch cool rain 50x100cm / 19½"x39"



studies in gouache grid white cloud 50x100cm / 19½"x39"





studies in gouache knit soft sand 50x100cm / 19¹/₂"x39" - gouache.10 deep sea 100x100cm / 39"x39"

SHADE

 Black Coffee

 Milk

4,9x100cm/2"x39"
slimtech 3plus

50x100cm/19 1/2"x39"
slimtech 3mm
slimtech 3plus

50x50cm/19 1/2"x19 1/2"
slimtech 3plus

100x100cm/39"x39"
slimtech 3plus



100x300cm/39"x118"
slimtech 3mm
slimtech 3plus

Imballi pag. 433
Packing
Emballage
Verpackung
Embalajes

GRES LAMINATO UGL
Laminated porcelain UGL
Grès laminé UGL
Laminiertes Feinsteinzeug UGL
Gres laminado UGL

SPESORE
Thickness
Epaisseur
Stärke
Espesor
3 mm → slimtech 3mm
3,5 mm → slimtech 3plus

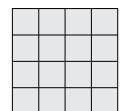
STONALIZZAZIONE
Shading
Denuançage
Spielfarbig
Grado de tonalización



V1

FUGA MINIMA CONSIGLIATA PER POSA IN INTERNO
Minimum suggested joint for indoor fixing
Joint minimum conseillé pour pose en entérieure
Empfohlene Fugenbreite fuer Innenbereich
Junta mínima aconsejada para colocación en interior

Parete / Wall / Mur / Wand / Revestimiento
1 mm → slimtech 3mm - slimtech 3plus

Pavimento / Floor / Sol / Boden / Pavimento
2 mm → slimtech 3plus

RESISTENZA ALLO SCIVOLAMENTO DIN 51130

Slip resistance
Résistance au glissement
Rutschfestigkeit
Resistencia antideslizante
R9 (3plus)

COEFFICIENTE DI ATTRITO DINAMICO B.C.R. TORTUS
 $\mu > 0,40$ (3plus)

COEFFICIENT OF FRICTION ASTM C1028
dry - COF ≥ 0.60 (3plus)
wet - COF ≥ 0.60 (3plus)

DYNAMIC COEFFICIENT OF FRICTION BOT 3000
DCOF ≥ 0.42 (3plus)



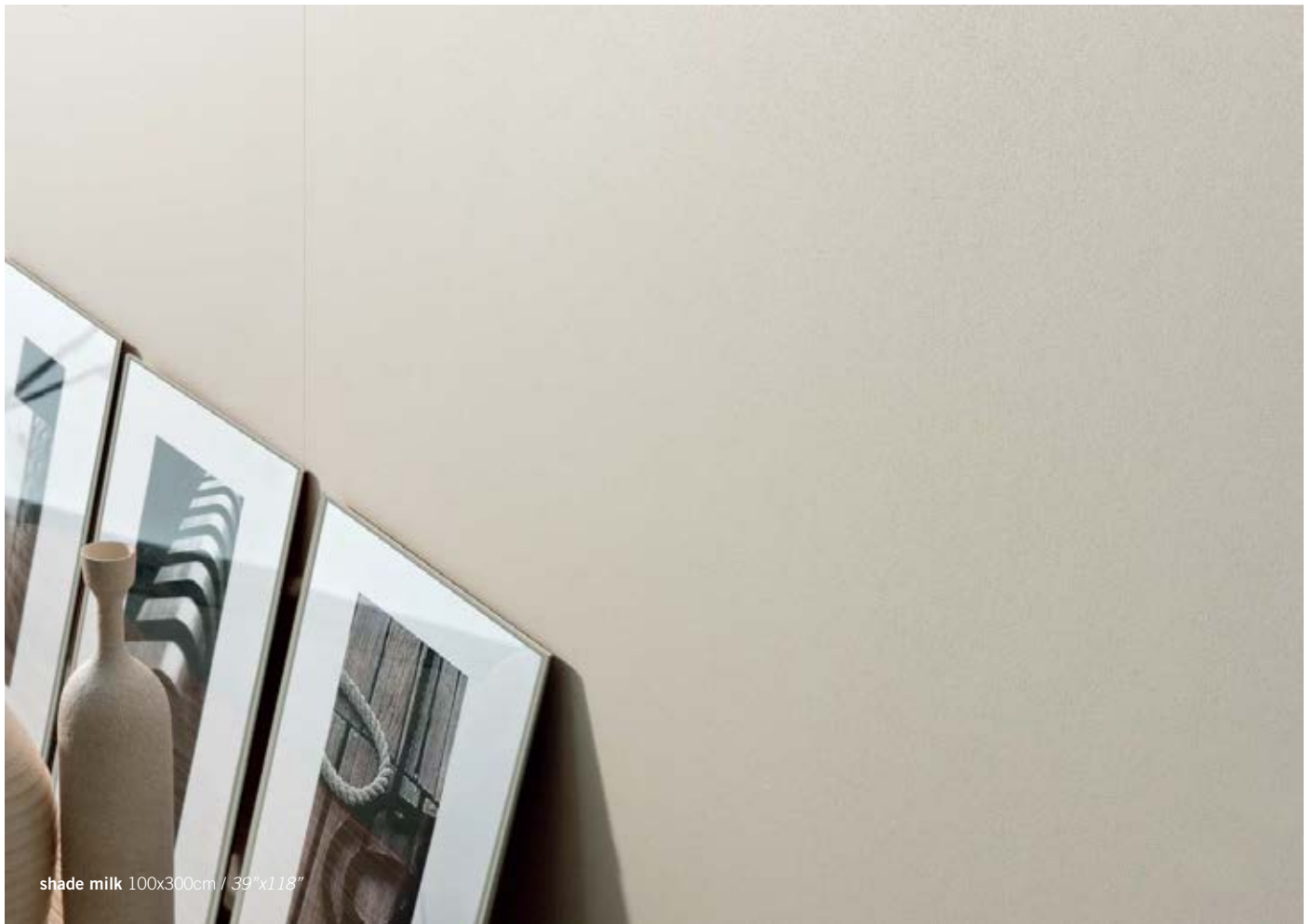

shade milk 100x300cm / 39"x118"



shade black coffee 100x100cm / 39"x39"



shade black coffee 100x300cm / 39"x118" - 100x100cm / 39"x39"

Shade Slimtech formati e colori

sizes and colors / formats et couleurs / formaten und farben / formatos y colores

black coffee



*100x300cm / 39"x118"
slimtech 3mm
slimtech 3plus

LSASD10 1560
LSASD15 1810



50x50cm / 19 1/2"x19 1/2"
slimtech 3plus LSBSD15 1620

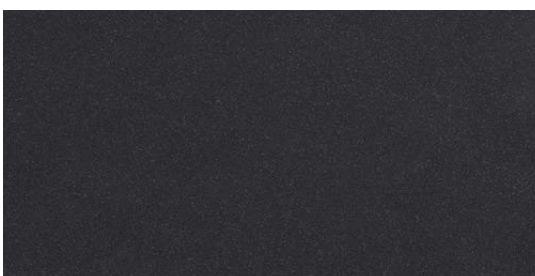

50x100cm / 19 1/2"x39"
slimtech 3mm
slimtech 3plus

LSBSD10 1400
LSBSD15 1620



100x100cm / 39"x39"
slimtech 3plus

LSCSD15 1750



4,9x100cm / 2"x39"
slimtech 3plus LSESD15 1930

*per ordini inferiori alle 5 lastre sarà addebitato il costo del pallet a Euro 80,00 netto. - the cost of the pallet, Euro 80,00 net, will be charged for orders less than 5 slabs. - pour toutes commandes inférieures à 5 dalles, un cout de 80 Euro correspondant au cout de la palette sera ajouté. - bei Abnahme einer Menge unter 5 Platten werden Euro 80,00 Netto für Verpackung/palette belastet. - Por pedidos inferiores a las 5 piezas adeudaremos el coste del palet de 80 Euro neto.

milk



*100x300cm / 39"x118"
slimtech 3mm
slimtech 3plus

LSASD00 1560
LSASD05 1810



50x50cm / 19¹/₂"x19¹/₂"
slimtech 3plus LSDSD05 1620



50x100cm / 19¹/₂"x39"
slimtech 3mm
slimtech 3plus

LSBSD00 1400
LSBSD05 1620



100x100cm / 39"x39"
slimtech 3plus

LSCSD05 1750



4,9x100cm / 2"x39"
slimtech 3plus LSESD05 1930

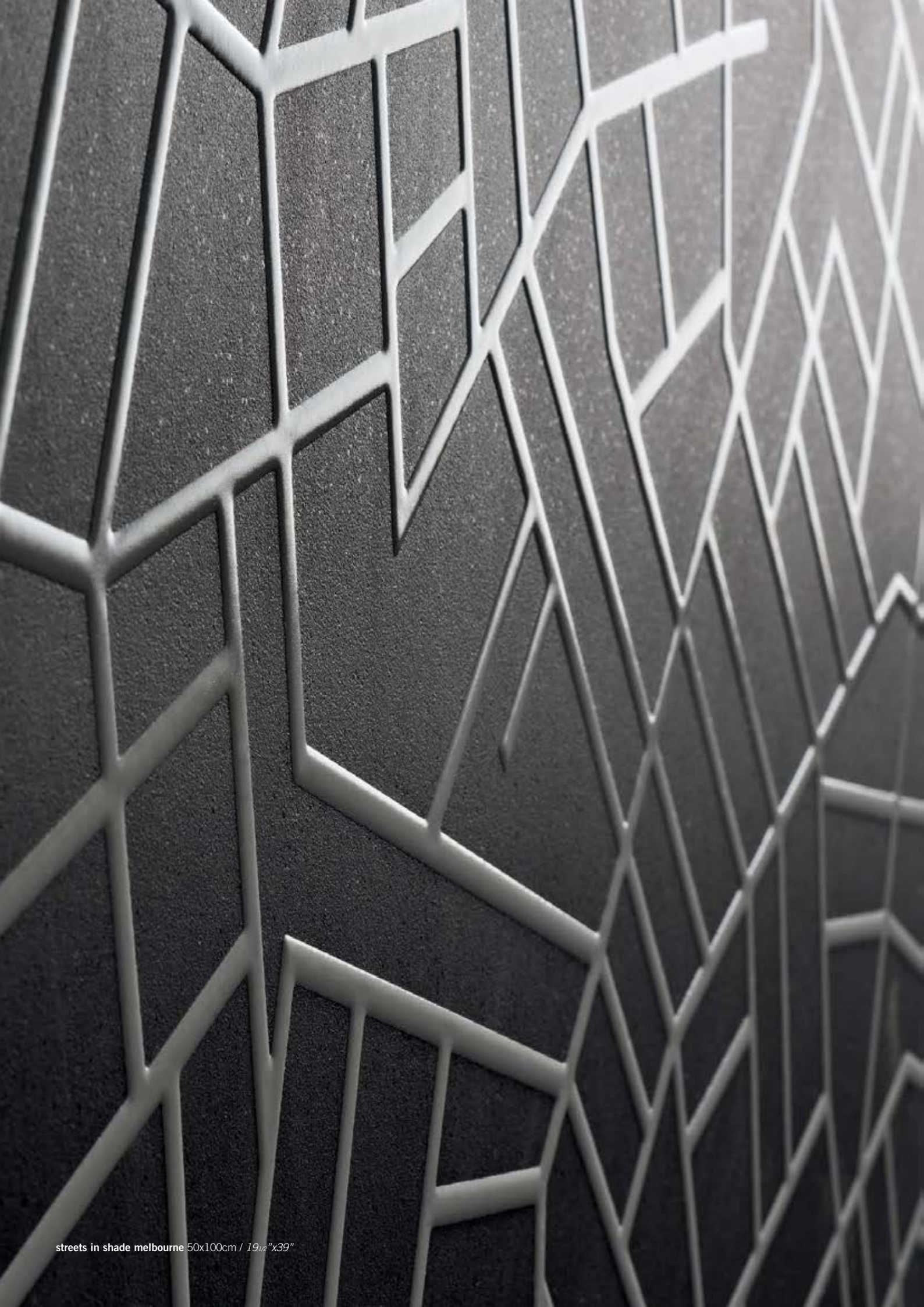

STREETS IN SHADE

design Diego Grandi

streets kyoto



50x100cm / 19 1/2"x39"
slimtech 3plus

LSBSD17 0575

streets melbourne



50x100cm / 19 1/2"x39"
slimtech 3plus

LSBSD18 0575

ARENARIA

 Avorio

 Sabbia

 Caramel

 Brown

4,9x100cm/2"x39"
slimtech 3mm
slimtech 3plus

50x100cm/19 1/2"x39"
slimtech 3mm
slimtech 3plus

50x50cm/19 1/2"x19 1/2"
slimtech 3plus

100x100cm/39"x39"
slimtech 3plus



100x300cm/39"x118"
slimtech 3mm
slimtech 3plus

Imballi pag. 425
Packing
Emballage
Verpackung
Embalajes

GRES LAMINATO UGL
Laminated porcelain UGL
Grès laminé UGL
Laminiertes Feinsteinzeug UGL
Gres laminado UGL

SPESSORE
Thickness
Epaisseur
Stärke
Espesor
3 mm → slimtech 3mm
3,5 mm → slimtech 3plus

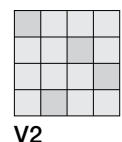
STONALIZZAZIONE
Shading
Denuançage
Spielfarbig
Grado de tonalización



V2

FUGA MINIMA CONSIGLIATA PER POSA IN INTERNO
Minimum suggested joint for indoor fixing
Joint minimum conseillé pour pose en enterieure
Empfohlene Fugenbreite fuer Innenbereich
Junta mínima aconsejada para colocación en interior

Parete / Wall / Mur / Wand / Revestimiento
1 mm → slimtech 3mm - slimtech 3plus

Pavimento / Floor / Sol / Boden / Pavimento
2 mm slimtech 3plus

RESISTENZA ALLO SCIVOLAMENTO DIN 51130

Slip resistance
Résistance au glissement
Rutschfestigkeit
Resistencia antideslizante
R9 (3plus)

COEFFICIENTE DI ATTRITO DINAMICO B.C.R. TORTUS
 $\mu > 0,40$ (3plus)

COEFFICIENT OF FRICTION ASTM C1028
dry - COF ≥ 0.60 (3plus)
wet - COF ≥ 0.60 (3plus)

DYNAMIC COEFFICIENT OF FRICTION BOT 3000
DCOF ≥ 0.42 (3plus)



arenaria avorio 100x300cm / 39"x118" - arenaria avorio 100x100cm / 39"x39"
arenaria avorio 50x50cm / 19½"x19½" - arenaria caramel 100x100cm / 39"x39"
mosaico listello caramel 25x50cm / 10"x19½"



arenaria sabbia 100x300cm / 39"x118" - arenaria brown 50x50cm / 19¹/₂"x19¹/₂"



arenaria caramel 100x300cm / 39"x118" - **arenaria caramel** 100x100cm / 39"x39"
arenaria caramel 50x50cm / 19.1/2"x19.1/2" - **arenaria caramel** 4,9x100cm / 2"x39"



arenaria sabbia 100x300cm / 39"x118" - **arenaria sabbia** 4,9x100cm / 2"x39"
arenaria brown 100x300cm / 39"x118" - **arenaria brown** 4,9x100cm / 2"x39"

Arenaria Slimtech formati e colori

sizes and colors / formats et couleurs / formaten und farben / formatos y colores

avorio



*100x300cm / 39"x118"
slimtech 3mm
slimtech 3plus

LSAAR00 1560
LSAAR05 1810



50x50cm / 19 1/2"x19 1/2"
slimtech 3plus LSDAR05 1620



50x100cm / 19 1/2"x39"
slimtech 3mm
slimtech 3plus

LSBAR00 1400
LSBAR05 1620



100x100cm / 39"x39"
slimtech 3plus

LSCAR05 1750



4,9x100cm / 2"x39"
slimtech 3mm LSEAR00 1750
slimtech 3plus LSEAR05 1930

*per ordini inferiori alle 5 lastre sarà addebitato il costo del pallet a Euro 80,00 netto. - the cost of the pallet, Euro 80,00 net, will be charged for orders less than 5 slabs. - pour toutes commandes inférieures à 5 dalles, un cout de 80 Euro correspondant au cout de la palette sera ajouté. - bei Abnahme einer Menge unter 5 Platten werden Euro 80,00 Netto für Verpackung/palette belastet. - Por pedidos inferiores a las 5 piezas adeudaremos el coste del palet de 80 Euro neto.

sabbia



*100x300cm / 39"x118"
slimtech 3mm
slimtech 3plus

LSAAR10 1560
LSAAR15 1810



50x50cm / 19 1/2"x19 1/2"
slimtech 3plus LSDAR15 1620

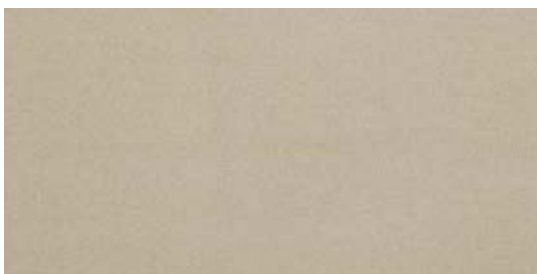

50x100cm / 19 1/2"x39"
slimtech 3mm
slimtech 3plus

LSBAR10 1400
LSBAR15 1620



100x100cm / 39"x39"
slimtech 3plus

LSCAR15 1750



4,9x100cm / 2"x39"
slimtech 3mm LSEAR10 1750
slimtech 3plus LSEAR15 1930

Arenaria Slimtech formati e colori

sizes and colors / formats et couleurs / formaten und farben / formatos y colores

caramel



*100x300cm / 39"x118"
slimtech 3mm
slimtech 3plus

LSAAR20 1560
LSAAR25 1810



50x50cm / 19 1/2"x19 1/2"
slimtech 3plus LSDAR25 1620



50x100cm / 19 1/2"x39"
slimtech 3mm
slimtech 3plus

LSBAR20 1400
LSBAR25 1620



100x100cm / 39"x39"
slimtech 3plus

LSCAR25 1750



4,9x100cm / 2"x39"
slimtech 3mm LSEAR20 1750
slimtech 3plus LSEAR25 1930

*per ordini inferiori alle 5 lastre sarà addebitato il costo del pallet a Euro 80,00 netto. - the cost of the pallet, Euro 80,00 net, will be charged for orders less than 5 slabs. - pour toutes commandes inférieures à 5 dalles, un cout de 80 Euro correspondant au cout de la palette sera ajouté. - bei Abnahme einer Menge unter 5 Platten werden Euro 80,00 Netto für Verpackung/palette belastet. - Por pedidos inferiores a las 5 piezas adeudaremos el coste del palet de 80 Euro neto.

brown



*100x300cm / 39"x118"
slimtech 3mm
slimtech 3plus

LSAAR30 1560
LSAAR35 1810



50x50cm / 19 1/2"x19 1/2"
slimtech 3plus LSDAR35 1620



50x100cm / 19 1/2"x39"
slimtech 3mm
slimtech 3plus

LSBAR30 1400
LSBAR35 1620



100x100cm / 39"x39"
slimtech 3plus

LSCAR35 1750



4,9x100cm / 2"x39"
slimtech 3mm LSEAR30 1750
slimtech 3plus LSEAR35 1930

Arenaria Slimtech corredi

decors / decors / dekore / decoros



MOSAICO MATTONE
avorio
25x25cm / 10"x10"
LS9AR00 0240



MOSAICO QUADRO
avorio
25x25cm / 10"x10"
LS9AR04 0330



MOSAICO STRISCIA
avorio
25x50cm / 10"x19 1/2"
LS9AR08 0470

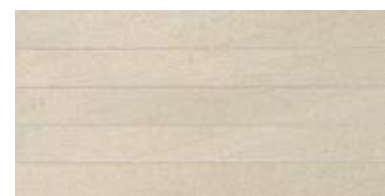

MOSAICO LISTELLO
avorio
25x50cm / 10"x19 1/2"
LS9AR12 0390



MOSAICO MATTONE
sabbia
25x25cm / 10"x10"
LS9AR01 0240



MOSAICO QUADRO
sabbia
25x25cm / 10"x10"
LS9AR05 0330

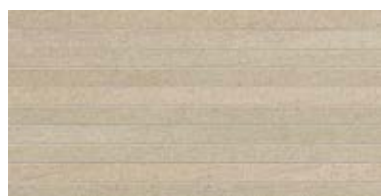

MOSAICO STRISCIA
sabbia
25x50cm / 10"x19 1/2"
LS9AR09 0470

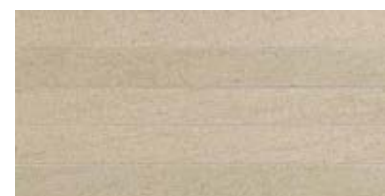

MOSAICO LISTELLO
sabbia
25x50cm / 10"x19 1/2"
LS9AR13 0390



MOSAICO MATTONE
caramello
25x25cm / 10"x10"
LS9AR02 0240



MOSAICO QUADRO
caramello
25x25cm / 10"x10"
LS9AR06 0330

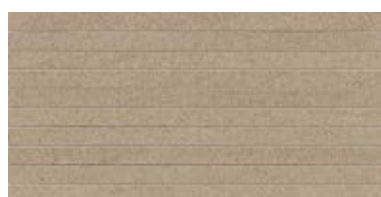

MOSAICO STRISCIA
caramello
25x50cm / 10"x19 1/2"
LS9AR10 0470



MOSAICO LISTELLO
caramello
25x50cm / 10"x19 1/2"
LS9AR14 0390

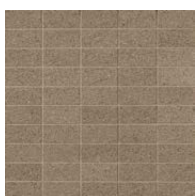

MOSAICO MATTONE
brown
25x25cm / 10"x10"
LS9AR03 0240

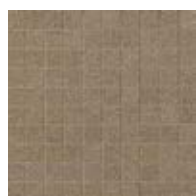

MOSAICO QUADRO
brown
25x25cm / 10"x10"
LS9AR07 0330



MOSAICO STRISCIA
brown
25x50cm / 10"x19 1/2"
LS9AR11 0470



MOSAICO LISTELLO
brown
25x50cm / 10"x19 1/2"
LS9AR15 0390



DECORO BAMBOO
50x100cm / 19 1/2"x39"
slimtech 3mm

LS9AR16 1850

BASALTINA STONE PROJECT

 Sabbaiata

 Naturale

 Lappata

 Stuccata

4,9x100cm/2"x39"
slimtech 3mm
slimtech 3plus

50x100cm/19 1/2"x39"
slimtech 3mm
slimtech 3plus

50x50cm/19 1/2"x19 1/2"
slimtech 3plus

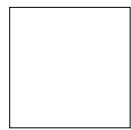
100x100cm/39"x39"
slimtech 3plus



100x300cm/39"x118"
slimtech 3mm
slimtech 3plus

Imballi pag. 427
Packing
Emballage
Verpackung
Embalajes

GRES LAMINATO UGL
Laminated porcelain UGL
Grès laminé UGL
Laminiertes Feinsteinzeug UGL
Gres laminado UGL

SPESORE
Thickness
Epaisseur
Stärke
Espesor
3 mm → slimtech 3mm
3,5 mm → slimtech 3plus

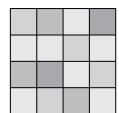
STONALIZZAZIONE
Shading
Denuançage
Spielfarbig
Grado de tonalización



V3

FUGA MINIMA CONSIGLIATA PER POSA IN INTERNO

Minimum suggested joint for indoor fixing
Joint minimum conseillé pour pose en enterieure
Empfohlene Fugenbreite fuer Innenbereich
Junta mínima aconsejada para colocación en interior

Parete / Wall / Mur / Wand / Revestimiento
1 mm → slimtech 3mm - slimtech 3plus

Pavimento / Floor / Sol / Boden / Pavimento
2 mm → slimtech 3plus

RESISTENZA ALLO SCIVOLAMENTO DIN 51130

Slip resistance
Résistance au glissement
Rutschfestigkeit
Resistencia antideslizante
R9 (3plus)

COEFFICIENTE DI ATTRITO DINAMICO B.C.R. TORTUS
 $\mu > 0,40$ (3plus)

COEFFICIENT OF FRICTION ASTM C1028
dry - COF ≥ 0.60 (3plus)
wet - COF ≥ 0.60 (3plus)

DYNAMIC COEFFICIENT OF FRICTION BOT 3000
DCOF ≥ 0.42 (3plus)



basaltina stone project naturale 100x300cm / 39"x118" - basaltina stone project lappata 50x100cm / 19 1/2"x39"
basaltina stone project lappata 4,9x100cm / 2"x39" - basaltina stone project plus naturale 100x100cm / 39"x39"





basaltina stone project sabbia 100x300cm / 39"x118" - mosaico mattone sabbia 25x25cm / 10"x10"
basaltina stone project sabbia 60x120cm / 24"x48"

Basaltina Stone Project Slimtech formati e colori

sizes and colors / formats et couleurs / formaten und farben / formatos y colores

sabbiata



*100x300cm / 39"x118"
slimtech 3mm
slimtech 3plus

LSABS00 1560
LSABS05 1810



50x50cm / 19 1/2"x19 1/2"
slimtech 3plus LSDBS05 1620



50x100cm / 19 1/2"x39"
slimtech 3mm
slimtech 3plus

LSBBS00 1400
LSBBS05 1620



100x100cm / 39"x39"
slimtech 3plus

LSCBS05 1750



4,9x100cm / 2"x39"
slimtech 3mm LSEBS00 1750
slimtech 3plus LSEBS05 1930

*per ordini inferiori alle 5 lastre sarà addebitato il costo del pallet a Euro 80,00 netto. - the cost of the pallet, Euro 80,00 net, will be charged for orders less than 5 slabs. - pour toutes commandes inférieures à 5 dalles, un cout de 80 Euro correspondant au cout de la palette sera ajouté. - bei Abnahme einer Menge unter 5 Platten werden Euro 80,00 Netto für Verpackung/palette belastet. - Por pedidos inferiores a las 5 piezas adeudaremos el coste del palet de 80 Euro neto.

naturale

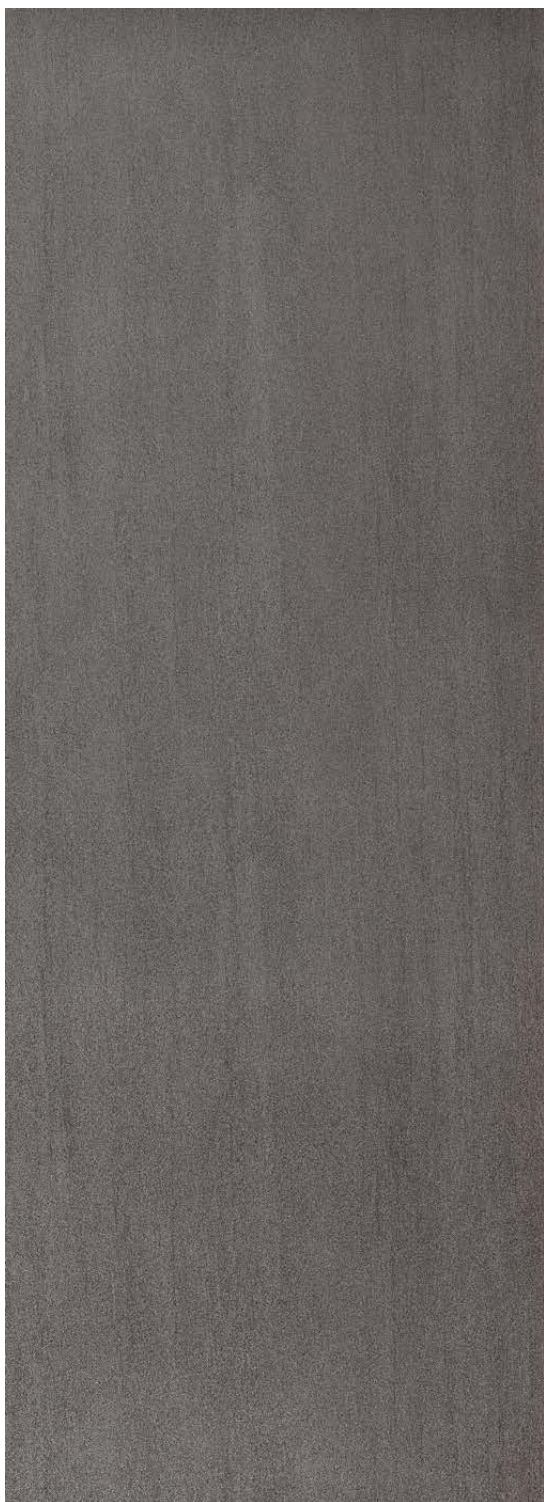

*100x300cm / 39"x118"
slimtech 3mm
slimtech 3plus

LSABS10 1560
LSABS15 1810



50x50cm / 19 1/2"x19 1/2"
slimtech 3plus LSDBS15 1620



50x100cm / 19 1/2"x39"
slimtech 3mm
slimtech 3plus

LSBBS10 1400
LSBBS15 1620



100x100cm / 39"x39"
slimtech 3plus

LSCBS15 1750



4,9x100cm / 2"x39"
slimtech 3mm LSEBS10 1750
slimtech 3plus LSEBS15 1930

Basaltina Stone Project Slimtech formati e colori

sizes and colors / formats et couleurs / formaten und farben / formatos y colores

stuccata



*100x300cm / 39"x118"
slimtech 3mm
slimtech 3plus

LSABS20 1560
LSABS25 1810



50x50cm / 19 1/2"x19 1/2"
slimtech 3plus LSDBS25 1620



50x100cm / 19 1/2"x39"
slimtech 3mm
slimtech 3plus

LSBBS20 1400
LSBBS25 1620

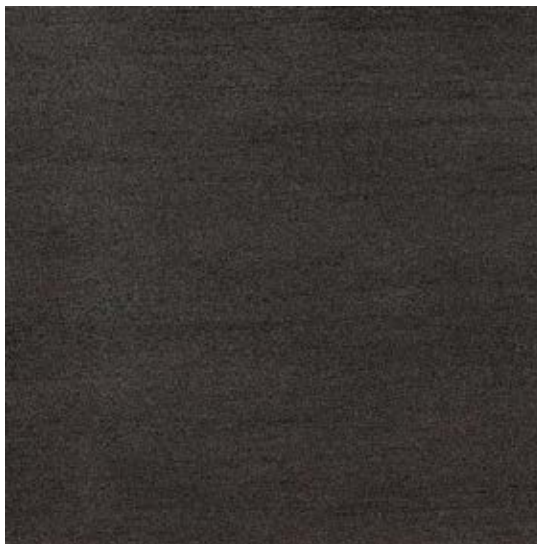

100x100cm / 39"x39"
slimtech 3plus

LSCBS25 1750



4,9x100cm / 2"x39"
slimtech 3mm LSEBS20 1750
slimtech 3plus LSEBS25 1930

*per ordini inferiori alle 5 lastre sarà addebitato il costo del pallet a Euro 80,00 netto. - the cost of the pallet, Euro 80,00 net, will be charged for orders less than 5 slabs. - pour toutes commandes inférieures à 5 dalles, un cout de 80 Euro correspondant au cout de la palette sera ajouté. - bei Abnahme einer Menge unter 5 Platten werden Euro 80,00 Netto für Verpackung/palette belastet. - Por pedidos inferiores a las 5 piezas adeudaremos el coste del palet de 80 Euro neto.

lappata

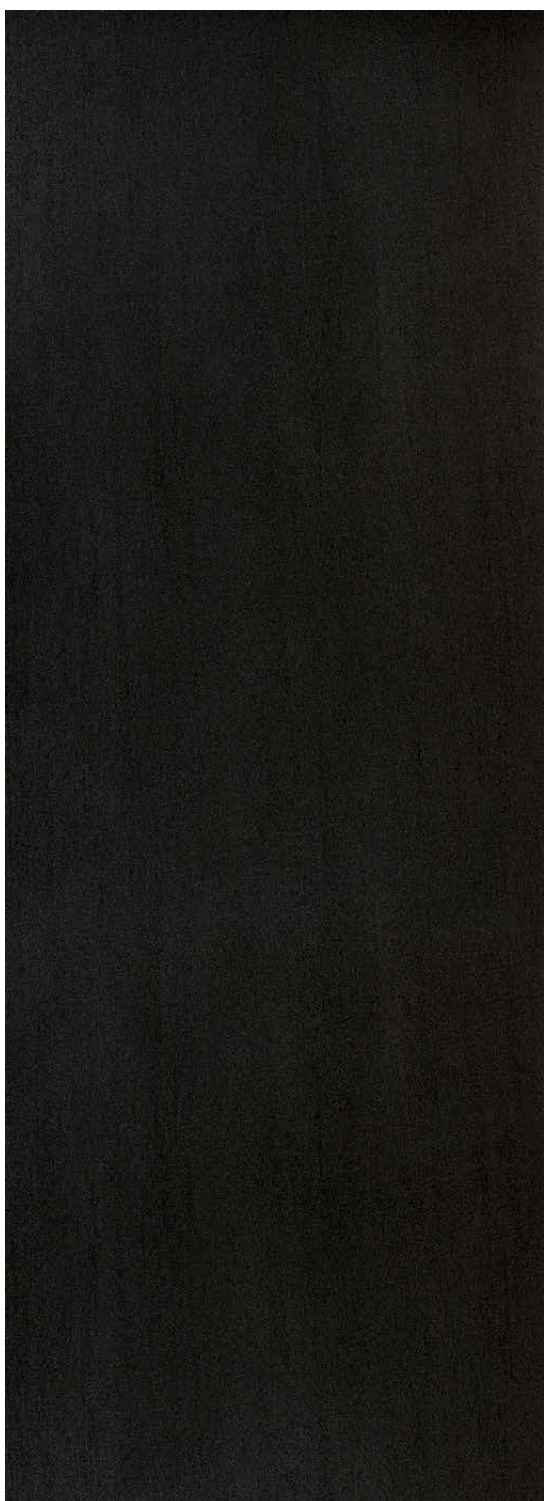

*100x300cm / 39"x118"
slimtech 3mm
slimtech 3plus

LSABS30 1560
LSABS35 1810



50x50cm / 19 1/2"x19 1/2"
slimtech 3plus LSDBS35 1620



50x100cm / 19 1/2"x39"
slimtech 3mm
slimtech 3plus

LSBBS30 1400
LSBBS35 1620

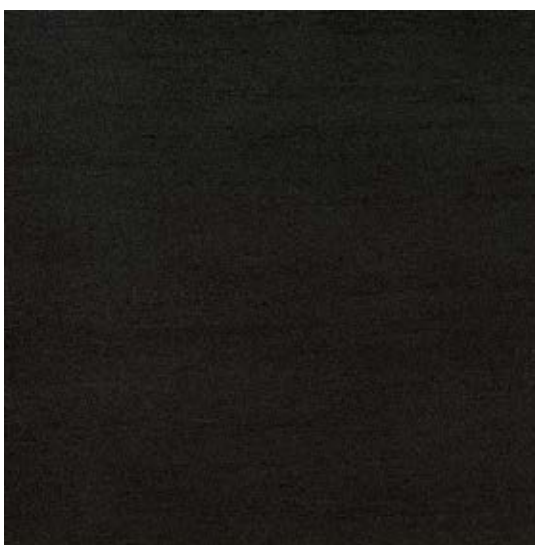

100x100cm / 39"x39"
slimtech 3plus

LSCBS35 1750



4,9x100cm / 2"x39"
slimtech 3mm LSEBS30 1750
slimtech 3plus LSEBS35 1930

Basaltina Stone Project Slimtech corredi

decors / decors / dekore / decoros



MOSAICO QUADRO
sabbia
25x25cm / 10"x10"
LS9BS00 0330



MOSAICO MATTONE
sabbia
25x25cm / 10"x10"
LS9BS10 0240



MOSAICO STRISCIA
sabbia
25x50cm / 10"x19 1/2"
LS9BS20 0470



MOSAICO LISTELLO
sabbia
25x50cm / 10"x19 1/2"
LS9BS30 0390

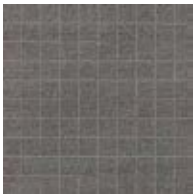

MOSAICO QUADRO
naturale
25x25cm / 10"x10"
LS9BS01 0330



MOSAICO MATTONE
naturale
25x25cm / 10"x10"
LS9BS11 0240



MOSAICO STRISCIA
naturale
25x50cm / 10"x19 1/2"
LS9BS21 0470



MOSAICO LISTELLO
naturale
25x50cm / 10"x19 1/2"
LS9BS31 0390



MOSAICO QUADRO
stuccata
25x25cm / 10"x10"
LS9BS02 0330



MOSAICO MATTONE
stuccata
25x25cm / 10"x10"
LS9BS12 0240

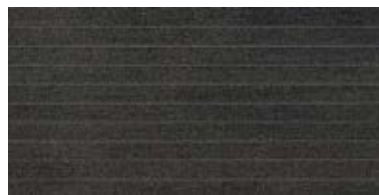

MOSAICO STRISCIA
stuccata
25x50cm / 10"x19 1/2"
LS9BS22 0470

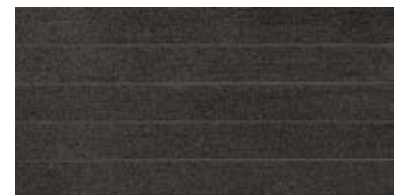

MOSAICO LISTELLO
stuccata
25x50cm / 10"x19 1/2"
LS9BS32 0390

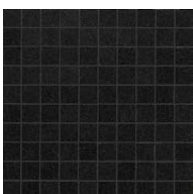

MOSAICO QUADRO
lappata
25x25cm / 10"x10"
LS9BS03 0330



MOSAICO MATTONE
lappata
25x25cm / 10"x10"
LS9BS13 0240

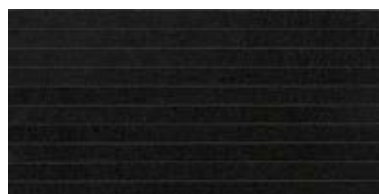

MOSAICO STRISCIA
lappata
25x50cm / 10"x19 1/2"
LS9BS23 0470



MOSAICO LISTELLO
lappata
25x50cm / 10"x19 1/2"
LS9BS33 0390



MOSAICO INOX
sabbiata
25x25cm / 10"x10"
LS9BS05 0750



MOSAICO SATIN
sabbiata
25x25cm / 10"x10"
LS9BS15 0750

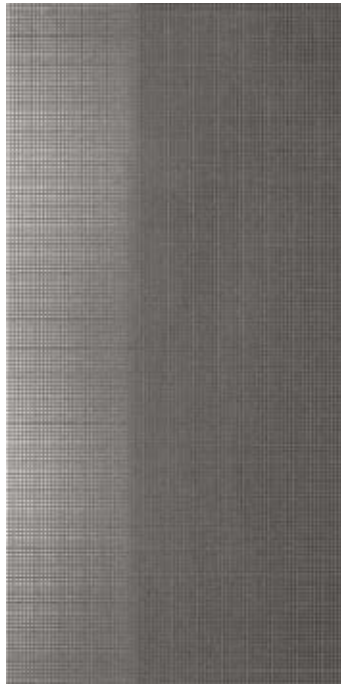

MOSAICO METAL
chiaro (naturale)
50x100cm / 19 1/2"x39"
slimtech 3mm LS9BS37 2110



MOSAICO GLITTER
chiaro (sabbiata)
50x100cm / 19 1/2"x39"
slimtech 3mm LS9BS35 2090



MOSAICO INOX
naturale
25x25cm / 10"x10"
LS9BS06 0750

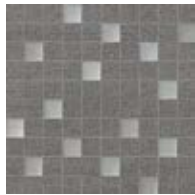

MOSAICO SATIN
naturale
25x25cm / 10"x10"
LS9BS16 0750

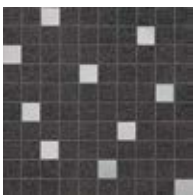

MOSAICO INOX
stuccata
25x25cm / 10"x10"
LS9BS07 0750

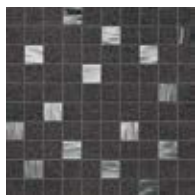

MOSAICO PEARL
stuccata
25x25cm / 10"x10"
LS9BS17 0750



MOSAICO METAL
scuro (lappata)
50x100cm / 19 1/2"x39"
slimtech 3mm LS9BS38 2110



MOSAICO GLITTER
scuro (stuccata)
50x100cm / 19 1/2"x39"
slimtech 3mm LS9BS36 2110

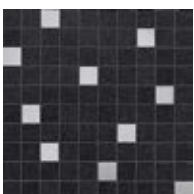

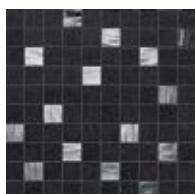

MOSAICO INOX
lappata
25x25cm / 10"x10"
LS9BS08 0750



MOSAICO PEARL
lappata
25x25cm / 10"x10"
LS9BS18 0750

LINES

design Patrick Norguet

-  Line Blue
-  Line Yellow
-  Line Grey



100x300cm/39"x118"
slimtech 3plus

Imballi pag. 430
Packing
Emballage
Verpackung
Embalajes

GRES LAMINATO UGL
Laminated porcelain UGL
Grès laminé UGL
Laminiertes Feinsteinzeug UGL
Gres laminado UGL

SPESSORE
Thickness
Epaisseur
Stärke
Espesor
3,5 mm → slimtech 3plus

STONALIZZAZIONE
Shading
Denuançage
Spielfarbig
Grado de tonalización

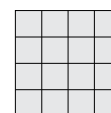

V1

FUGA MINIMA CONSIGLIATA
Minimum grout joint recommended
Joint minimum conseillé
Empfohlene Minimalfugenbreit
Distancia recomendada entre las baldosas

Parete / Wall / Mur / Wand / Revestimiento
1 mm → slimtech 3plus



Lines Slimtech formati e colori

sizes and colors / formats et couleurs / formaten und farben / formatos y colores

line blue

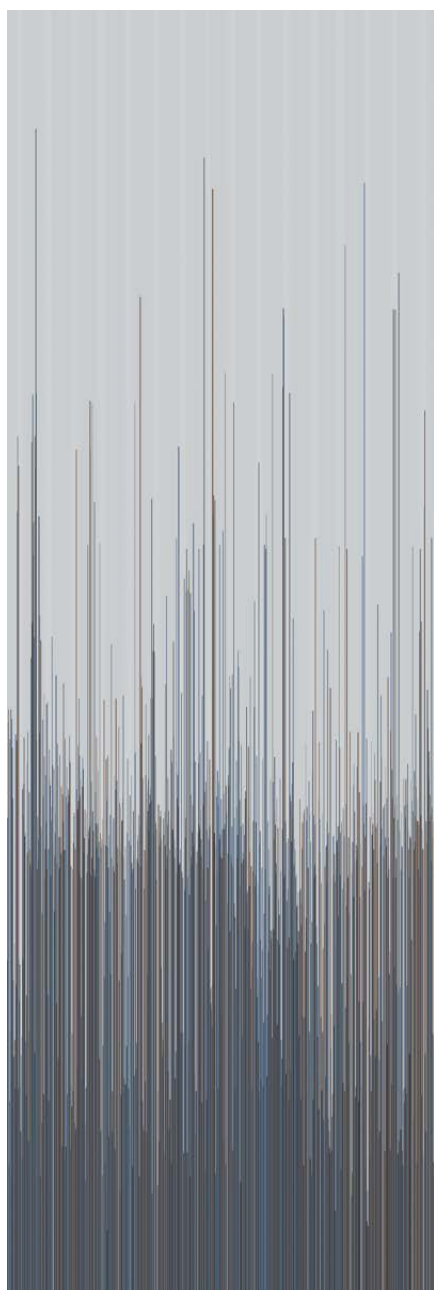

*100x300cm / 39"x118"
slimtech 3plus

LSALI06 1890

line yellow

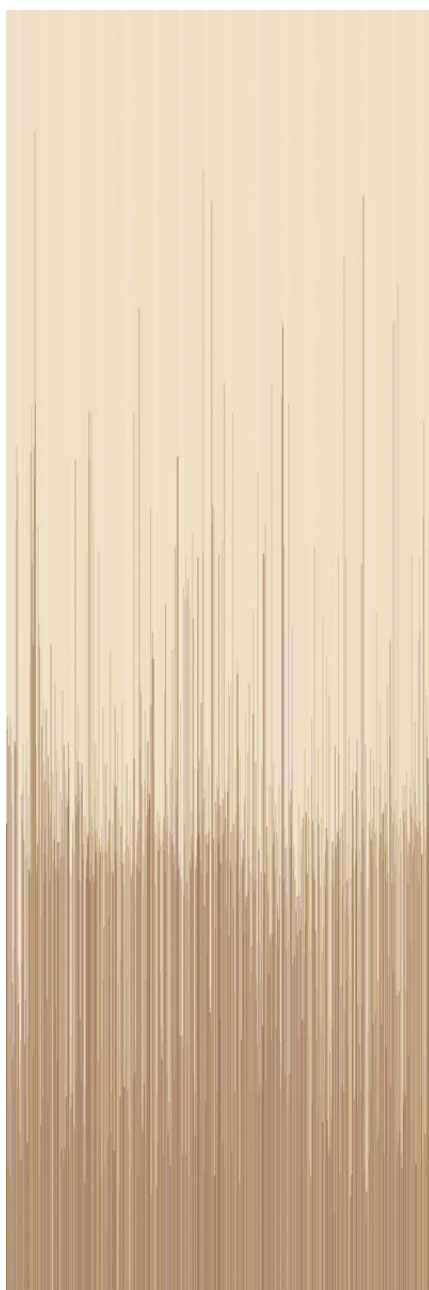

*100x300cm / 39"x118"
slimtech 3plus

LSALI16 1890

line grey

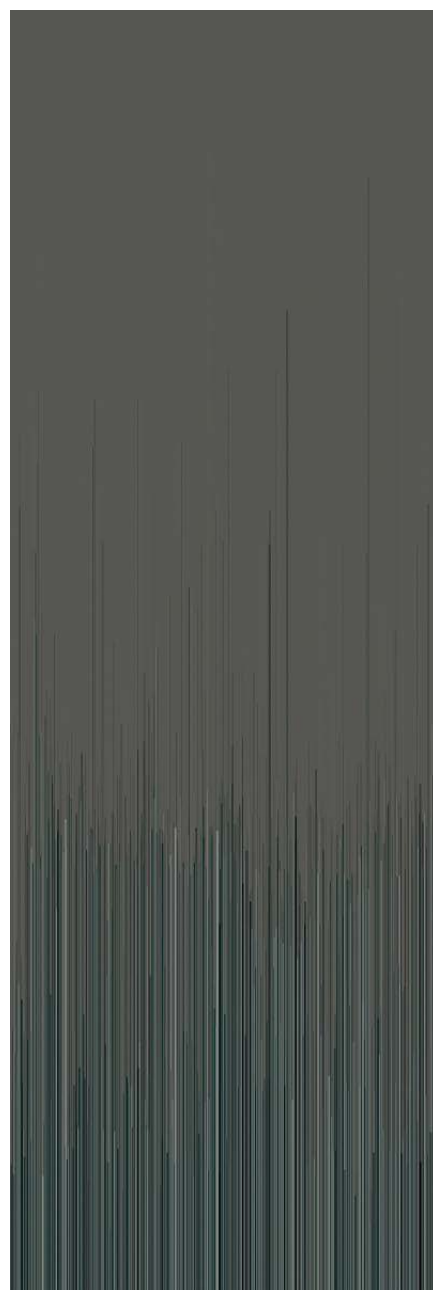

*100x300cm / 39"x118"
slimtech 3plus

LSALI26 1890



*per ordini inferiori alle 5 lastre sarà addebitato il costo del pallet a Euro 80,00 netto. - the cost of the pallet, Euro 80,00 net, will be charged for orders less than 5 slabs. - pour toutes commandes inférieures à 5 dalles, un cout de 80 Euro correspondant au cout de la palette sera ajouté. - bei Abnahme einer Menge unter 5 Platten werden Euro 80,00 Netto für Verpackung/palette belastet. - Por pedidos inferiores a las 5 piezas adeudaremos el coste del palet de 80 Euro neto.



line grey 100x300cm / 39"x118"

WAVES

design Patrick Norguet

-  Wave Blue
-  Wave Green
-  Wave Grey

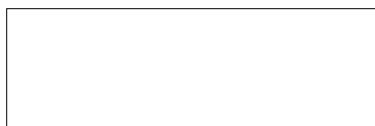

100x300cm/39"x118"
slimtech 3plus

Imballi pag. 436
Packing
Emballage
Verpackung
Embalajes

GRES LAMINATO UGL
Laminated porcelain UGL
Grès laminé UGL
Laminiertes Feinsteinzeug UGL
Gres laminado UGL

SPESSORE
Thickness
Epaisseur
Stärke
Espesor
3,5 mm → slimtech 3plus

STONALIZZAZIONE
Shading
Denuançage
Spielfarbig
Grado de tonalización

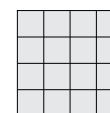

V1

FUGA MINIMA CONSIGLIATA
Minimum grout joint recommended
Joint minimum conseillé
Empfohlene Minimalfugenbreit
Distancia recomendada entre las baldosas

Parete / Wall / Mur / Wand / Revestimiento
1 mm → slimtech 3plus



Waves Slimtech formati e colori

sizes and colors / formats et couleurs / formaten und farben / formatos y colores

wave blue a

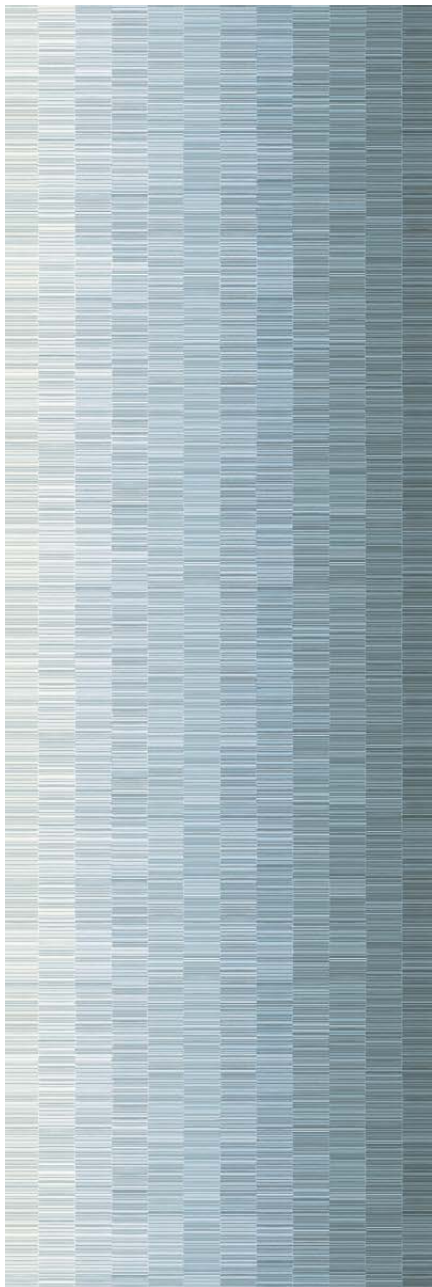

*100x300cm / 39"x118"
slimtech 3plus

LSAWA08 1890

wave green a

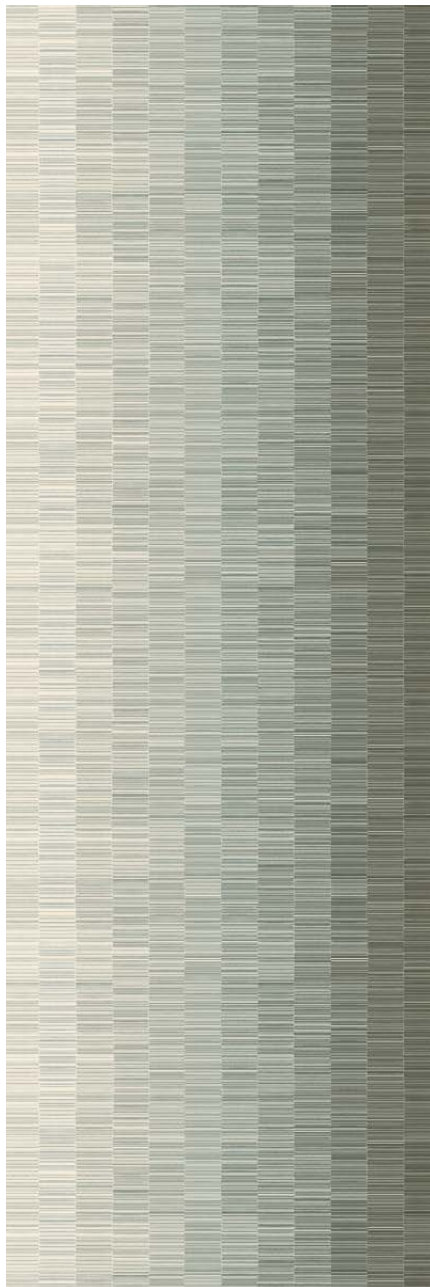

*100x300cm / 39"x118"
slimtech 3plus

LSAWA18 1890

wave grey a



*100x300cm / 39"x118"
slimtech 3plus

LSAWA28 1890

a	b	a	b	a	b
---	---	---	---	---	---

*per ordini inferiori alle 5 lastre sarà addebitato il costo del pallet a Euro 80,00 netto. - the cost of the pallet, Euro 80,00 net, will be charged for orders less than 5 slabs. - pour toutes commandes inférieures à 5 dalles, un cout de 80 Euro correspondant au cout de la palette sera ajouté. - bei Abnahme einer Menge unter 5 Platten werden Euro 80,00 Netto für Verpackung/palette belastet. - Por pedidos inferiores a las 5 piezas adeudaremos el coste del palet de 80 Euro neto.

wave blue b

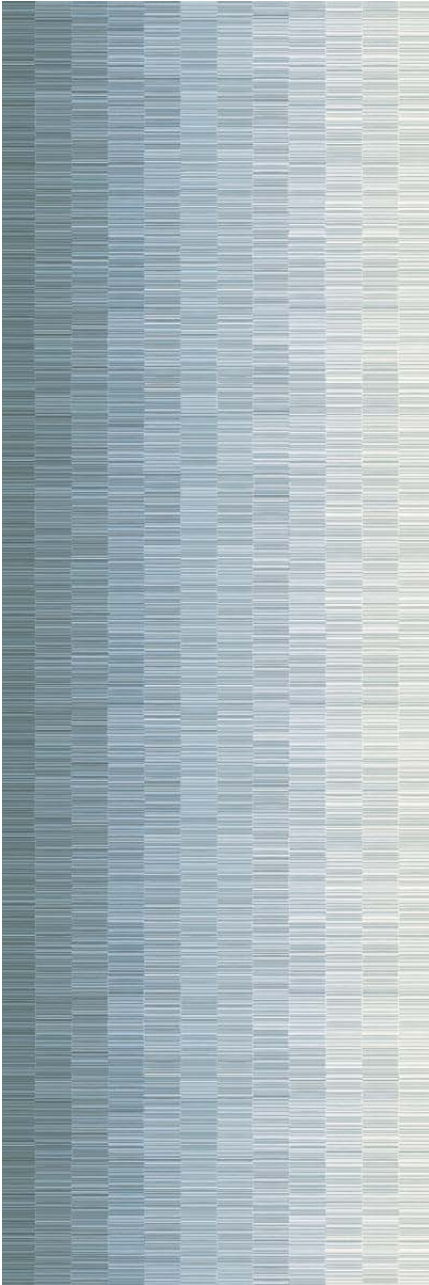

*100x300cm / 39"x118"
slimtech 3plus

LSAWA09 1890

wave green b

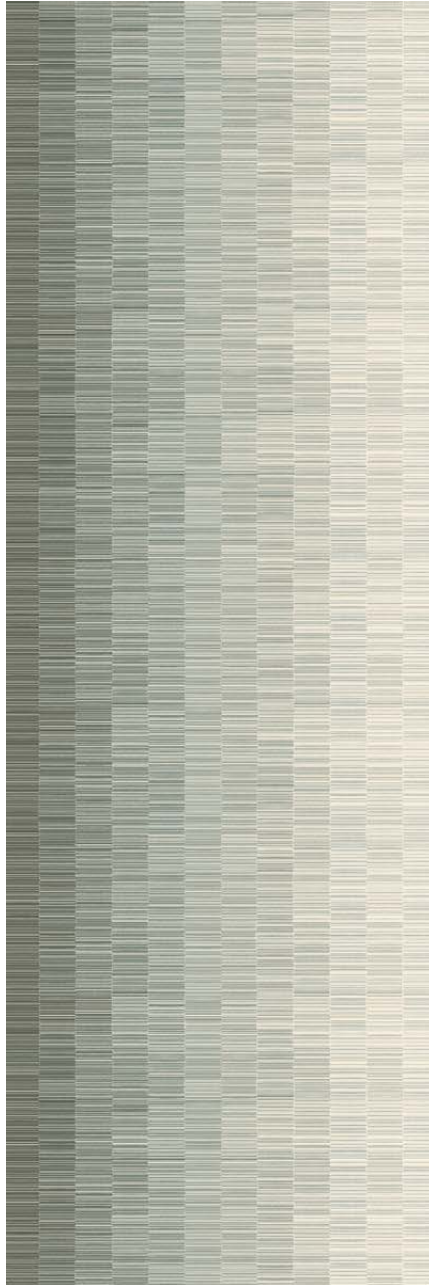

*100x300cm / 39"x118"
slimtech 3plus

LSAWA19 1890

wave grey b

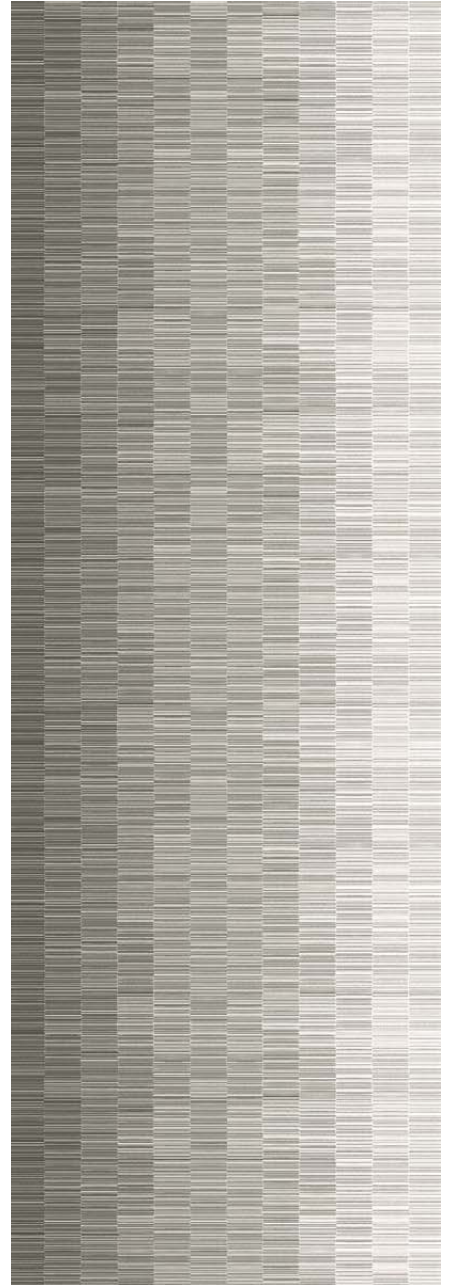

*100x300cm / 39"x118"
slimtech plus

LSAWA29 1890

MAUK

design Diego Grandi

 Sabbiata

 Naturale

 Lappata

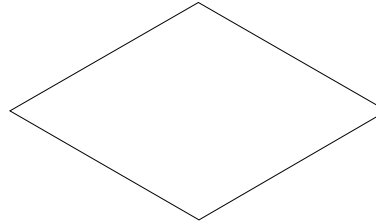

lati 57,6cm/22^{5/8}"
slimtech 3plus

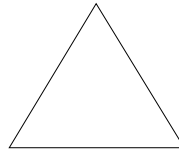

lati 38,3cm/15^{1/8}"
slimtech 3plus

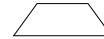

base maggiore 25,8cm/10^{1/8}"
base minore 13,5cm/5^{3/8}"
lati 8,7cm/3^{3/8}"
slimtech 3mm

Imballi pag. 430

Packing
Emballage
Verpackung
Embalajes

GRES LAMINATO UGL

Laminated porcelain UGL
Grès laminé UGL
Laminiertes Feinsteinzeug UGL
Gres laminado UGL

SPESORE

Thickness
Epaisseur
Stärke
Espesor

3 mm → slimtech 3mm (cuadra - esa)
3,5 mm → slimtech 3plus (spina)

STONALIZZAZIONE

Shading
Denuançage
Spielfarbig
Grado de tonalización

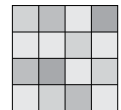

V3

FUGA MINIMA CONSIGLIATA PER POSA IN INTERNO

Minimum suggested joint for indoor fixing
Joint minimum conseillé pour pose en enterieure
Empfohlene Fugenbreite fuer Innenbereich
Junta mínima aconsejada para colocación en interior

Parete / Wall / Mur / Wand / Revestimiento
1 mm → slimtech 3mm - slimtech 3plus

Pavimento / Floor / Sol / Boden / Pavimento
2 mm → slimtech 3plus

COEFFICIENTE DI ATTRITO DINAMICO B.C.R. TORTUS

$\mu > 0,40$ (3plus)

COEFFICIENT OF FRICTION ASTM C1028

dry - COF $\geq 0,60$ (3plus)
wet - COF $\geq 0,60$ (3plus)

RESISTENZA ALLO SCIVOLAMENTO DIN 51130

Slip resistance
Résistance au glissement
Rutschfestigkeit
Resistencia antideslizante
R9 (3plus)

DYNAMIC COEFFICIENT OF FRICTION BOT 3000

DCOF $\geq 0,42$ (3plus)



mauk cuadra bsp plus sabbiata 57,6cm / 22^{5/8}" - mauk cuadra bsp plus naturale 57,6cm / 22^{5/8}"
mauk cuadra bsp plus lappata 57,6cm / 22^{5/8}"

Mauk Slimtech formati e colori

sizes and colors / formats et couleurs / formaten und farben / formatos y colores

cuadra



57,6cm / 22⁵/₈"
bsp slimtech 3plus sabbia
LS9MK05 0810

esa

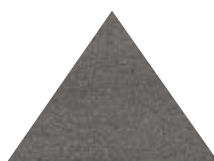

38,3cm / 15¹/₈"
bsp slimtech 3plus naturale
LS9MK04 0240

spina



8,7x13,5x25,8cm / 3³/₈"x5³/₈"x10¹/₈"
bsp slimtech 3mm sabbia
LS9MK01 0030



57,6cm / 22⁵/₈"
bsp slimtech 3plus naturale
LS9MK06 0810



38,3cm / 15¹/₈"
bsp slimtech 3plus lappata
LS9MK03 0240



8,7x13,5x25,8cm / 3³/₈"x5³/₈"x10¹/₈"
bsp slimtech 3mm lappata
LS9MK00 0030











57,6cm / 22⁵/₈"
bsp slimtech 3plus lappata
LS9MK07 0810



mauk spina bsp lappata 8,7x13,5x25,8cm / 3₃₈"x5₃₈"x10₁₈" - mauk cuadra bsp plus sabbia 57,6cm / 22₅₈"
mauk cuadra bsp plus naturale 57,6cm / 22₅₈" - mauk cuadra bsp plus lappata 57,6cm / 22₅₈"

SUPERFICI CONTEMPORANEE

110	METROPOLIS
124	ARENARIA
132	SALENTO
140	BLUE MOUNTAIN
150	BASALTINA STONE PROJECT
160	MAKÒ
168	STONEHENGE
176	CITY

	Tokyo White
	Paris Amande
	Milano Ecrú
	Rio Coffee
	London Gray
	Shanghai Iron
	New York Coal
	Berlin Night

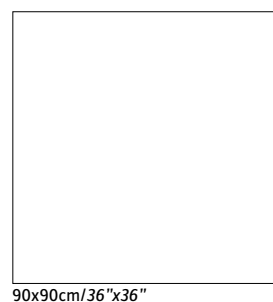
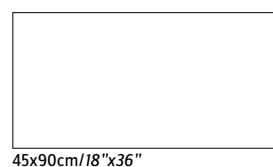
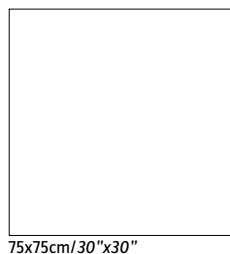
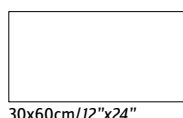

Imballi pag. 431
 Packing
 Emballage
 Verpackung
 Embalajes

GRES TUTTA MASSA UGL

Full-body porcelain
 Grès Cérame pleine masse
 Vollgemischtes Durchgefärbtes Feinsteinzeug
 Gres toda masa UGL

FUGA MINIMA CONSIGLIATA

Minimum grout joint recommended
 Joint minimum conseillé
 Empfohlene Minimalfugenbreit
 Distancia recomendada entre las baldosas
 2 mm

RESISTENZA ALLO SCIVOLAMENTO DIN 51130

Slip resistance
 Résistance au glissement
 Rutschfestigkeit
 Resistencia antideslizante

R10 (naturale/spazzolato/texture)
 R11 (texture grip)

RESISTENZA ALLO SCIVOLAMENTO DIN 51097

Slip resistance
 Résistance au glissement
 Rutschfestigkeit
 Resistencia antideslizante
 classe C (texture grip)

SPESSORE

Thickness
 Epaisseur
 Stärke
 Espesor
 10 mm (30x60 - 60x60)
 11 mm (75x75 - 45x90 - 90x90)

COEFFICIENTE DI ATTRITO DINAMICO B.C.R. TORTUS

$\mu > 0,40$

COEFFICIENT OF FRICTION ASTM C1028

dry - COF ≥ 0.60
 wet - COF ≥ 0.60

DYNAMIC COEFFICIENT OF FRICTION BOT 3000

DCOF ≥ 0.42

STONALIZZAZIONE

Shading
 Denuançage
 Spielfarbig
 Grado de tonalización

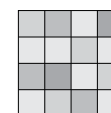

V3

BRITISH PENDULUM TEST

BS 7976:2002

4S (slider 96)
 dry: low slip potential PTV 36+ (naturale/texture grip)
 wet: moderate slip potential PTV 25-35 (naturale)
 low slip potential PTV 36+ (texture grip)

TRL (slider 55)

dry: low slip potential PTV 36+ (texture grip)
 wet: low slip potential PTV 36+ (texture grip)

WET PENDULUM TEST AS/NZS 4586:2004

class X (texture grip)

Info Microban pag. 396

ANTIBACTERIAL



metropolis rio coffee 75x75cm / 30"x30" spazz. rett. - metropolis milano ecru 60x60cm / 24"x24" nat.
metropolis bacchetta metal moka 1,5x60cm / 5/8"x24"



metropolis new york coal 75x75cm / 30"x30" spazz. rett.



metropolis tokyo white 60x60cm / 24"x24" texture grip rett. - metropolis tokyo white 30x60cm / 12"x24" texture grip rett.



metropolis rio coffee 75x75cm / 30"x30" spazz. rett. - metropolis milano ecru 60x60cm / 24"x24" nat.
metropolis muretto avenue 3D tokyo white 30x60cm / 12"x24" - metropolis bacchetta metal moka 1,5x60cm / 5/8"x24"



metropolis shanghai iron 90x90cm / 36"x36" texture rett.



metropolis rio coffee 75x75cm / 30"x30" spazz. rett. - **metropolis milano ecru** 60x60cm / 24"x24" texture grip



metropolis london gray 75x75cm / 30"x30" spazz. rett. - **metropolis london gray** 30x60cm / 12"x24" nat. rett.

Metropolis formati e colori

sizes and colors / formats et couleurs / formaten und farben / formatos y colores

tokyo white

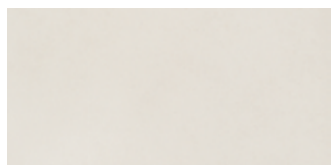

30x60cm / 12"x24"
nat. rett. (spessore 10mm) LGVML10 0955



60x60cm / 24"x24"
nat. rett. (spessore 10mm) LGWML1R 0955



75x75cm / 30"x30"
spazz. rett. (spessore 11mm) LGOML10 1185

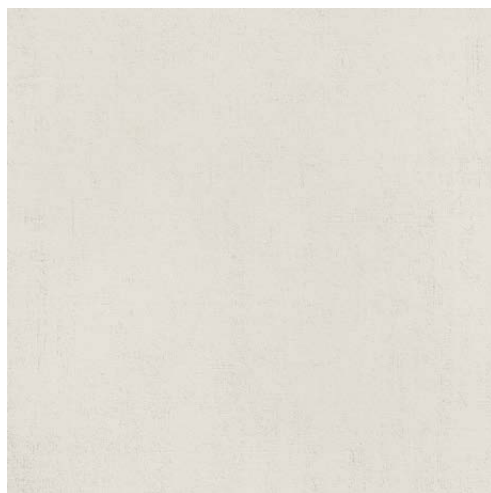

90x90cm / 36"x36"
texture rett. (spessore 11mm) LG9ML10 1445

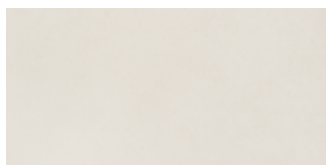

30x60cm / 12"x24"
*txt grip rett. (spessore 10mm) LGVML16 1025



60x60cm / 24"x24"
*txt grip rett. (spessore 10mm) LGWML16 1025

*non trattato con antibatterico
without antimicrobial treatment
sans traitement antibacterien
nicht mit antibakterieller
Wirkung ausgestattet

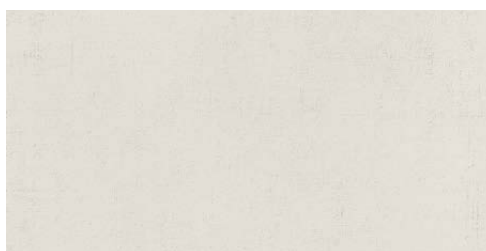

45x90cm / 18"x36"
texture rett. (spessore 11mm) LGGML10 1445

milano ecru



30x60cm / 12"x24"
nat. rett. (spessore 10mm) LGVML20 0955



30x60cm / 12"x24"
*txt grip rett. (spessore 10mm) LGVML26 1025



60x60cm / 24"x24"
nat. rett. (spessore 10mm) LGWML2R 0955



60x60cm / 24"x24"
*txt grip rett. (spessore 10mm) LGWML26 1025

*non trattato con antibatterico
without antimicrobial treatment
sans traitement antibacterien
nicht mit antibakterieller
Wirkung ausgestattet



75x75cm / 30"x30"
spazz. rett. (spessore 11mm) LGOML20 1185



90x90cm / 36"x36"
texture rett. (spessore 11mm) LG9ML20 1445



45x90cm / 18"x36"
texture rett. (spessore 11mm) LGGML20 1445

Metropolis formati e colori

sizes and colors / formats et couleurs / formaten und farben / formatos y colores

shanghai iron



30x60cm / 12"x24"
nat. rett. (spessore 10mm) LGVML50 0955



60x60cm / 24"x24"
nat. rett. (spessore 10mm) LGWML5R 0955



75x75cm / 30"x30"
spazz. rett. (spessore 11mm) LGOML50 1185

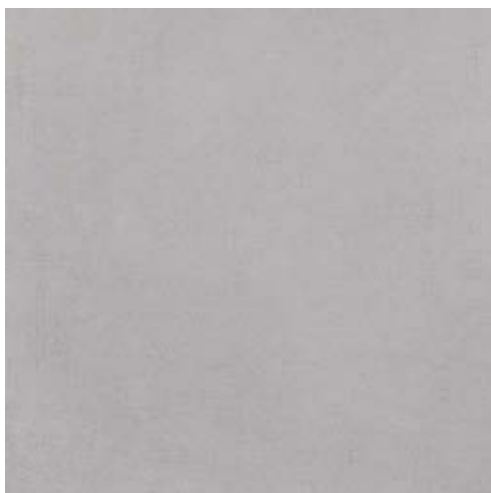

90x90cm / 36"x36"
texture rett. (spessore 11mm) LG9ML50 1445



30x60cm / 12"x24"
*txt grip rett. (spessore 10mm) LGVML56 1025

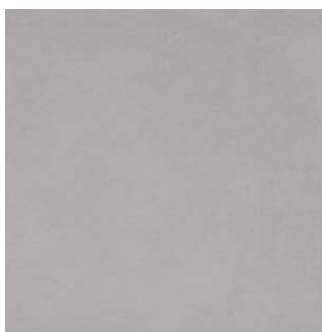

60x60cm / 24"x24"
*txt grip rett. (spessore 10mm) LGWML56 1025

*non trattato con antibatterico
without antimicrobial treatment
sans traitement antibacterien
nicht mit antibakterieller
Wirkung ausgestattet



45x90cm / 18"x36"
texture rett. (spessore 11mm) LGGML50 1445

rio coffee



30x60cm / 12"x24"
nat. rett. (spessore 10mm) LGVML00 0955



60x60cm / 24"x24"
nat. rett. (spessore 10mm) LGWML0R 0955



75x75cm / 30"x30"
spazz. rett. (spessore 11mm) LGOML00 1185

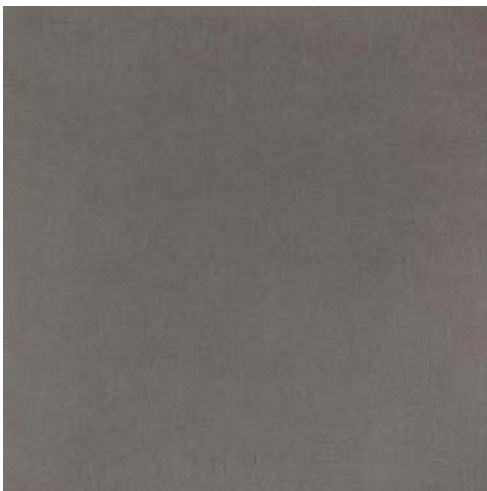

90x90cm / 36"x36"
texture rett. (spessore 11mm) LG9ML00 1445



30x60cm / 12"x24"
*txt grip rett. (spessore 10mm) LGVML06 1025



60x60cm / 24"x24"
*txt grip rett. (spessore 10mm) LGWML06 1025

*non trattato con antibatterico
without antimicrobial treatment
sans traitement antibacterien
nicht mit antibakterieller
Wirkung ausgestattet



45x90cm / 18"x36"
texture rett. (spessore 11mm) LGGML00 1445

Metropolis formati e colori

sizes and colors / formats et couleurs / formaten und farben / formatos y colores

berlin night

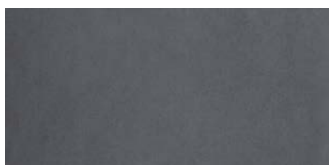

30x60cm / 12"x24"
nat. rett. (spessore 10mm) LGVML70 0955

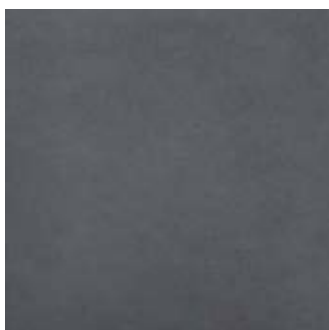

60x60cm / 24"x24"
nat. rett. (spessore 10mm) LGWML7R 0955



75x75cm / 30"x30"
spazz. rett. (spessore 11mm) LGOML70 1185



90x90cm / 36"x36"
texture rett. (spessore 11mm) LG9ML70 1445



45x90cm / 18"x36"
texture rett. (spessore 11mm) LGGML70 1445

paris amande



30x60cm / 12"x24"
nat. rett. (spessore 10mm) LGVML30 0955



60x60cm / 24"x24"
nat. rett. (spessore 10mm) LGWML3R 0955



75x75cm / 30"x30"
spazz. rett. (spessore 11mm) LGOML30 1185

london gray



30x60cm / 12"x24"
nat. rett. (spessore 10mm) LGVML60 0955



60x60cm / 24"x24"
nat. rett. (spessore 10mm) LGWML6R 0955



75x75cm / 30"x30"
spazz. rett. (spessore 11mm) LGOML60 1185

new york coal



30x60cm / 12"x24"
nat. rett. (spessore 10mm) LGVML40 0955



60x60cm / 24"x24"
nat. rett. (spessore 10mm) LGWML4R 0955



75x75cm / 30"x30"
spazz. rett. (spessore 11mm) LGOML40 1185

Metropolis corredi

decors / decors / dekore / decoros



MURETTO AVENUE 3D
30x60cm / 12"x24"
tokyo white **LG9MLM1 1035**



MURETTO URBAN
30x60cm / 12"x24"
cold **LG9MLC0 0505**



MURETTO AVENUE 3D
30x60cm / 12"x24"
milano ecru **LG9MLM2 1035**



MURETTO URBAN
30x60cm / 12"x24"
warm **LG9MLW0 0505**



MURETTO AVENUE 3D
30x60cm / 12"x24"
shanghai iron **LG9MLM5 1035**



BACCHETTA METAL*
1,5x60cm / 5/8"x24"
titanio **LG9ML0T 0395**



MURETTO AVENUE 3D
30x60cm / 12"x24"
rio coffee **LG9MLM0 1035**



BACCHETTA METAL*
1,5x60cm / 5/8"x24"
nero **LG9ML0N 0395**



MURETTO AVENUE 3D
30x60cm / 12"x24"
berlin night **LG9MLM7 1035**



BACCHETTA METAL*
1,5x60cm / 5/8"x24"
moka **LG9ML0G 0395**

*non trattato con antibatterico
without antimicrobial treatment
sans traitement antibacterien
nicht mit antibakterieller
Wirkung ausgestattet

Metropolis pezzi speciali

trims / pièces spéciales / formstücke / piezas especiales

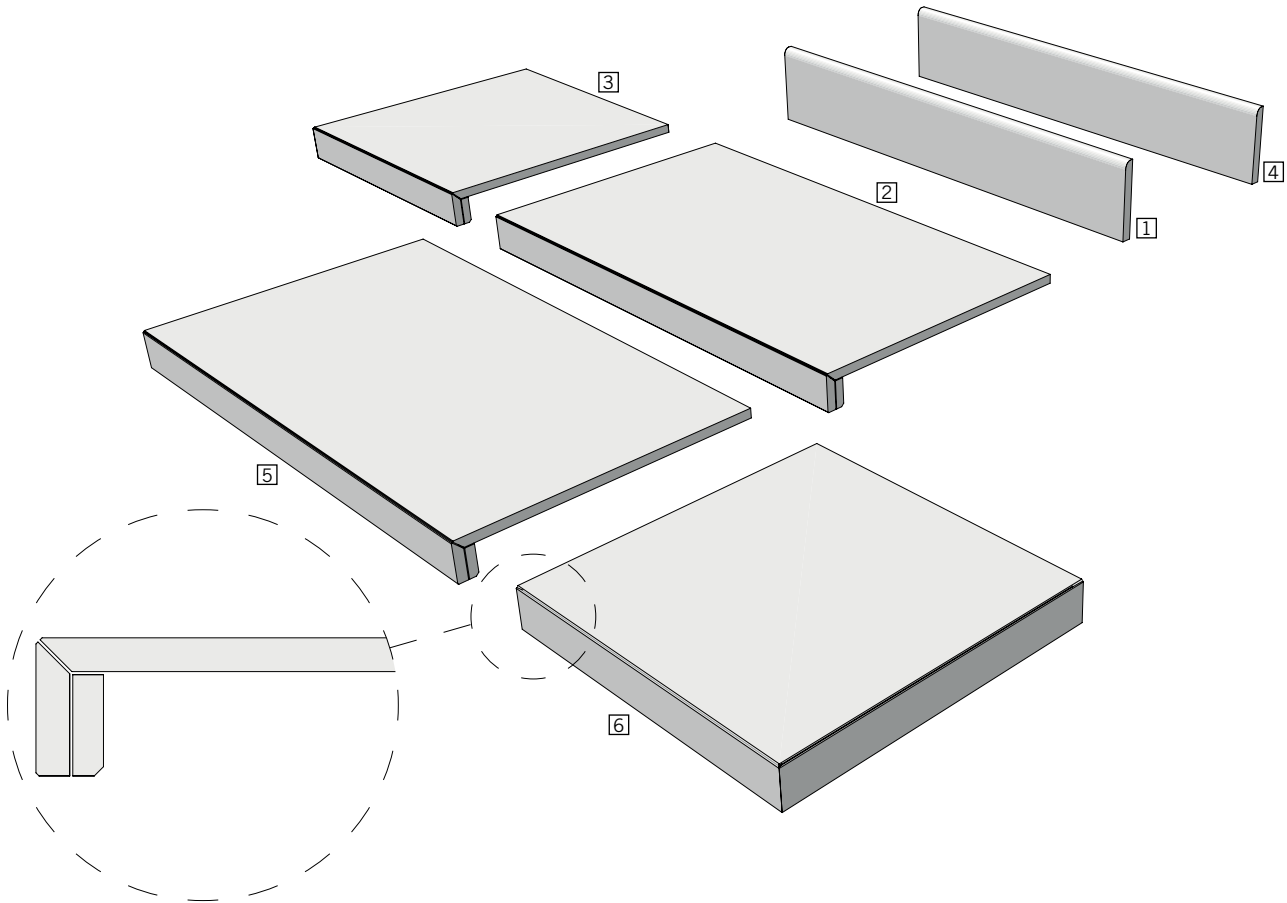

nat.

- | | | | | | | | | | | | | | | | | | | | | | | | | | | | | | | | | | | | | | | | | | | | | | | | | | | |
|---|--------------|--------------|--------------|--------------|-------------|--------------|------------|--------------|-------------|--------------|---------------|--------------|---------------|--------------|--------------|--------------|--|-------------|--------------|--------------|--------------|-------------|--------------|------------|--------------|-------------|--------------|---------------|--------------|---------------|--------------|--------------|--------------|---|-------------|--------------|--------------|--------------|-------------|--------------|------------|--------------|-------------|--------------|---------------|--------------|---------------|--------------|--------------|--------------|
| <p>1 BATTISCOPA nat. rett.
10x60cm / 4"x24"</p> <table border="0"> <tr><td>tokyo white</td><td>LGBMLN1 0200</td></tr> <tr><td>paris amande</td><td>LGBMLN3 0200</td></tr> <tr><td>milano ecru</td><td>LGBMLN2 0200</td></tr> <tr><td>rio coffee</td><td>LGBMLN0 0200</td></tr> <tr><td>london gray</td><td>LGBMLN6 0200</td></tr> <tr><td>shanghai iron</td><td>LGBMLN5 0200</td></tr> <tr><td>new york coal</td><td>LGBMLN4 0200</td></tr> <tr><td>berlin night</td><td>LGBMLN7 0200</td></tr> </table> | tokyo white | LGBMLN1 0200 | paris amande | LGBMLN3 0200 | milano ecru | LGBMLN2 0200 | rio coffee | LGBMLN0 0200 | london gray | LGBMLN6 0200 | shanghai iron | LGBMLN5 0200 | new york coal | LGBMLN4 0200 | berlin night | LGBMLN7 0200 | <p>2 GRADINO PLUS nat. rett.
35x60cm / 13^{3/4}"x24"</p> <table border="0"> <tr><td>tokyo white</td><td>LG9MLG1 1630</td></tr> <tr><td>paris amande</td><td>LG9MLG3 1630</td></tr> <tr><td>milano ecru</td><td>LG9MLG2 1630</td></tr> <tr><td>rio coffee</td><td>LG9MLG0 1630</td></tr> <tr><td>london gray</td><td>LG9MLG6 1630</td></tr> <tr><td>shanghai iron</td><td>LG9MLG5 1630</td></tr> <tr><td>new york coal</td><td>LG9MLG4 1630</td></tr> <tr><td>berlin night</td><td>LG9MLG7 1630</td></tr> </table> | tokyo white | LG9MLG1 1630 | paris amande | LG9MLG3 1630 | milano ecru | LG9MLG2 1630 | rio coffee | LG9MLG0 1630 | london gray | LG9MLG6 1630 | shanghai iron | LG9MLG5 1630 | new york coal | LG9MLG4 1630 | berlin night | LG9MLG7 1630 | <p>3 ANGOLO SX / DX GRADINO PLUS nat. rett.
35x35cm / 13^{3/4}"x13^{3/4}"</p> <table border="0"> <tr><td>tokyo white</td><td>LG9MLA1 1970</td></tr> <tr><td>paris amande</td><td>LG9MLA3 1970</td></tr> <tr><td>milano ecru</td><td>LG9MLA2 1970</td></tr> <tr><td>rio coffee</td><td>LG9MLA0 1970</td></tr> <tr><td>london gray</td><td>LG9MLA6 1970</td></tr> <tr><td>shanghai iron</td><td>LG9MLA5 1970</td></tr> <tr><td>new york coal</td><td>LG9MLA4 1970</td></tr> <tr><td>berlin night</td><td>LG9MLA7 1970</td></tr> </table> | tokyo white | LG9MLA1 1970 | paris amande | LG9MLA3 1970 | milano ecru | LG9MLA2 1970 | rio coffee | LG9MLA0 1970 | london gray | LG9MLA6 1970 | shanghai iron | LG9MLA5 1970 | new york coal | LG9MLA4 1970 | berlin night | LG9MLA7 1970 |
| tokyo white | LGBMLN1 0200 | | | | | | | | | | | | | | | | | | | | | | | | | | | | | | | | | | | | | | | | | | | | | | | | | |
| paris amande | LGBMLN3 0200 | | | | | | | | | | | | | | | | | | | | | | | | | | | | | | | | | | | | | | | | | | | | | | | | | |
| milano ecru | LGBMLN2 0200 | | | | | | | | | | | | | | | | | | | | | | | | | | | | | | | | | | | | | | | | | | | | | | | | | |
| rio coffee | LGBMLN0 0200 | | | | | | | | | | | | | | | | | | | | | | | | | | | | | | | | | | | | | | | | | | | | | | | | | |
| london gray | LGBMLN6 0200 | | | | | | | | | | | | | | | | | | | | | | | | | | | | | | | | | | | | | | | | | | | | | | | | | |
| shanghai iron | LGBMLN5 0200 | | | | | | | | | | | | | | | | | | | | | | | | | | | | | | | | | | | | | | | | | | | | | | | | | |
| new york coal | LGBMLN4 0200 | | | | | | | | | | | | | | | | | | | | | | | | | | | | | | | | | | | | | | | | | | | | | | | | | |
| berlin night | LGBMLN7 0200 | | | | | | | | | | | | | | | | | | | | | | | | | | | | | | | | | | | | | | | | | | | | | | | | | |
| tokyo white | LG9MLG1 1630 | | | | | | | | | | | | | | | | | | | | | | | | | | | | | | | | | | | | | | | | | | | | | | | | | |
| paris amande | LG9MLG3 1630 | | | | | | | | | | | | | | | | | | | | | | | | | | | | | | | | | | | | | | | | | | | | | | | | | |
| milano ecru | LG9MLG2 1630 | | | | | | | | | | | | | | | | | | | | | | | | | | | | | | | | | | | | | | | | | | | | | | | | | |
| rio coffee | LG9MLG0 1630 | | | | | | | | | | | | | | | | | | | | | | | | | | | | | | | | | | | | | | | | | | | | | | | | | |
| london gray | LG9MLG6 1630 | | | | | | | | | | | | | | | | | | | | | | | | | | | | | | | | | | | | | | | | | | | | | | | | | |
| shanghai iron | LG9MLG5 1630 | | | | | | | | | | | | | | | | | | | | | | | | | | | | | | | | | | | | | | | | | | | | | | | | | |
| new york coal | LG9MLG4 1630 | | | | | | | | | | | | | | | | | | | | | | | | | | | | | | | | | | | | | | | | | | | | | | | | | |
| berlin night | LG9MLG7 1630 | | | | | | | | | | | | | | | | | | | | | | | | | | | | | | | | | | | | | | | | | | | | | | | | | |
| tokyo white | LG9MLA1 1970 | | | | | | | | | | | | | | | | | | | | | | | | | | | | | | | | | | | | | | | | | | | | | | | | | |
| paris amande | LG9MLA3 1970 | | | | | | | | | | | | | | | | | | | | | | | | | | | | | | | | | | | | | | | | | | | | | | | | | |
| milano ecru | LG9MLA2 1970 | | | | | | | | | | | | | | | | | | | | | | | | | | | | | | | | | | | | | | | | | | | | | | | | | |
| rio coffee | LG9MLA0 1970 | | | | | | | | | | | | | | | | | | | | | | | | | | | | | | | | | | | | | | | | | | | | | | | | | |
| london gray | LG9MLA6 1970 | | | | | | | | | | | | | | | | | | | | | | | | | | | | | | | | | | | | | | | | | | | | | | | | | |
| shanghai iron | LG9MLA5 1970 | | | | | | | | | | | | | | | | | | | | | | | | | | | | | | | | | | | | | | | | | | | | | | | | | |
| new york coal | LG9MLA4 1970 | | | | | | | | | | | | | | | | | | | | | | | | | | | | | | | | | | | | | | | | | | | | | | | | | |
| berlin night | LG9MLA7 1970 | | | | | | | | | | | | | | | | | | | | | | | | | | | | | | | | | | | | | | | | | | | | | | | | | |

texture grip*

- | | | | | | | | | | | | | | | | | | | | | | | | | | | |
|--|--------------|--------------|-------------|--------------|------------|--------------|---------------|--------------|---|-------------|--------------|-------------|--------------|------------|--------------|---------------|--------------|--|-------------|--------------|-------------|--------------|------------|--------------|---------------|--------------|
| <p>4 BATTISCOPA texture grip rett.*
10x60cm / 4"x24"</p> <table border="0"> <tr><td>tokyo white</td><td>LGBMLT1 0200</td></tr> <tr><td>milano ecru</td><td>LGBMLT2 0200</td></tr> <tr><td>rio coffee</td><td>LGBMLT0 0200</td></tr> <tr><td>shanghai iron</td><td>LGBMLT5 0200</td></tr> </table> | tokyo white | LGBMLT1 0200 | milano ecru | LGBMLT2 0200 | rio coffee | LGBMLT0 0200 | shanghai iron | LGBMLT5 0200 | <p>5 GRADINO PLUS texture grip rett.*
35x60cm / 13^{3/4}"x24"</p> <table border="0"> <tr><td>tokyo white</td><td>LG9MLY1 1630</td></tr> <tr><td>milano ecru</td><td>LG9MLY2 1630</td></tr> <tr><td>rio coffee</td><td>LG9MLY0 1630</td></tr> <tr><td>shanghai iron</td><td>LG9MLY5 1630</td></tr> </table> | tokyo white | LG9MLY1 1630 | milano ecru | LG9MLY2 1630 | rio coffee | LG9MLY0 1630 | shanghai iron | LG9MLY5 1630 | <p>6 ANGOLO SX / DX GRADINO PLUS texture grip rett.*
35x35cm / 13^{3/4}"x13^{3/4}"</p> <table border="0"> <tr><td>tokyo white</td><td>LG9MLX1 1970</td></tr> <tr><td>milano ecru</td><td>LG9MLX2 1970</td></tr> <tr><td>rio coffee</td><td>LG9MLX0 1970</td></tr> <tr><td>shanghai iron</td><td>LG9MLX5 1970</td></tr> </table> | tokyo white | LG9MLX1 1970 | milano ecru | LG9MLX2 1970 | rio coffee | LG9MLX0 1970 | shanghai iron | LG9MLX5 1970 |
| tokyo white | LGBMLT1 0200 | | | | | | | | | | | | | | | | | | | | | | | | | |
| milano ecru | LGBMLT2 0200 | | | | | | | | | | | | | | | | | | | | | | | | | |
| rio coffee | LGBMLT0 0200 | | | | | | | | | | | | | | | | | | | | | | | | | |
| shanghai iron | LGBMLT5 0200 | | | | | | | | | | | | | | | | | | | | | | | | | |
| tokyo white | LG9MLY1 1630 | | | | | | | | | | | | | | | | | | | | | | | | | |
| milano ecru | LG9MLY2 1630 | | | | | | | | | | | | | | | | | | | | | | | | | |
| rio coffee | LG9MLY0 1630 | | | | | | | | | | | | | | | | | | | | | | | | | |
| shanghai iron | LG9MLY5 1630 | | | | | | | | | | | | | | | | | | | | | | | | | |
| tokyo white | LG9MLX1 1970 | | | | | | | | | | | | | | | | | | | | | | | | | |
| milano ecru | LG9MLX2 1970 | | | | | | | | | | | | | | | | | | | | | | | | | |
| rio coffee | LG9MLX0 1970 | | | | | | | | | | | | | | | | | | | | | | | | | |
| shanghai iron | LG9MLX5 1970 | | | | | | | | | | | | | | | | | | | | | | | | | |

 Avorio

 Sabbia

 Caramel

 Brown



30x60cm/12"x24"
30x60,4cm/12"x24"



60x60cm/24"x24"
60,4x60,4cm/24"x24"



60x120cm/24"x48"

Imballi pag. 425

Packing
Emballage
Verpackung
Embalajes

GRES TUTTA MASSA UGL

Full-body porcelain
Grès Cérame pleine masse
Vollgemischtes Durchgefärbtes Feinsteinzeug
Gres toda masa UGL

SPESSORE

Thickness
Epaisseur
Stärke
Espesor

STONALIZZAZIONE

Shading
Denuançage
Spielfarbig
Grado de tonalización

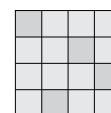

V2

FUGA MINIMA CONSIGLIATA

Minimum grout joint recommended
Joint minimum conseillé
Empfohlene Minimalfugenbreit
Distancia recomendada entre las baldosas

9 mm (30x60,4)
10 mm (30x60 - 60x60 - 60,4x60,4)
11 mm (60x120)

2 mm rettificato
4 mm naturale

RESISTENZA ALLO SCIVOLAMENTO DIN 51130

Slip resistance
Résistance au glissement
Rutschfestigkeit
Resistencia antideslizante

R10

COEFFICIENTE DI ATTRITO DINAMICO B.C.R. TORTUS

$\mu > 0,40$

COEFFICIENT OF FRICTION ASTM C1028

dry - COF ≥ 0.60
wet - COF ≥ 0.60

ANTIBACTERIAL





arenaria caramel 60x60cm / 24"x24"



arenaria sabbia 30x60cm / 12"x24"



arenaria brown 60x60cm / 24"x24"

Arenaria formati e colori

sizes and colors / formats et couleurs / formaten und farben / formatos y colores

avorio



30x60cm / 12"x24"
nat. rett. (spessore 10mm) LGVARR5 1240
30x60,4cm / 12"x24"
nat. (spessore 9mm) LGVAR50 1060

sabbia



30x60cm / 12"x24"
nat. rett. (spessore 10mm) LGVARR6 1240
30x60,4cm / 12"x24"
nat. (spessore 9mm) LGVAR60 1060



60x60cm / 24"x24"
nat. rett. (spessore 10mm) LGWARR5 1240
60,4x60,4cm / 24"x24"
nat. (spessore 9mm) LGWARB5 1060



60x60cm / 24"x24"
nat. rett. (spessore 10mm) LGWARR6 1240
60,4x60,4cm / 24"x24"
nat. (spessore 9mm) LGWARB6 1060



60x120cm / 24"x48"
nat. rett. (spessore 10mm) LGXARR5 1580



60x120cm / 24"x48"
nat. rett. (spessore 10mm) LGXARR6 1580

caramel



30x60cm / 12"x24"
nat. rett. (spessore 10mm) **LGVARR7 1240**
30x60,4cm / 12"x24"
nat. (spessore 9mm) **LGVAR70 1060**

brown



30x60cm / 12"x24"
nat. rett. (spessore 10mm) **LGVARR8 1240**
30x60,4cm / 12"x24"
nat. (spessore 9mm) **LGVAR80 1060**



60x60cm / 24"x24"
nat. rett. (spessore 10mm) **LGWARR7 1240**
60,4x60,4cm / 24"x24"
nat. (spessore 9mm) **LGWARB7 1060**



60x60cm / 24"x24"
nat. rett. (spessore 10mm) **LGWARR8 1240**
60,4x60,4cm / 24"x24"
nat. (spessore 9mm) **LGWARB8 1060**



60x120cm / 24"x48"
nat. rett. (spessore 10mm) **LGXARR7 1580**



60x120cm / 24"x48"
nat. rett. (spessore 10mm) **LGXARR8 1580**

Arenaria corredi

decors / decors / dekore / decoros



MOSAICO 1
avorio
28,5x28,5cm / 11¼"x11¼"
LG9AR50 0500



LINK
chiaro
30x60cm / 12"x24"
LG9AR55 1880



MOSAICO 1
sabbia
28,5x28,5cm / 11¼"x11¼"
LG9AR51 0500



LINK
scuro
30x60cm / 12"x24"
LG9AR56 1880

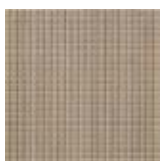

MOSAICO 1
caramel
28,5x28,5cm / 11¼"x11¼"
LG9AR52 0500

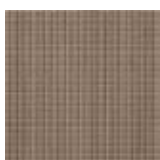

MOSAICO 1
brown
28,5x28,5cm / 11¼"x11¼"
LG9AR53 0500

Arenaria pezzi speciali

trims / pièces spéciales / formstücke / piezas especiales

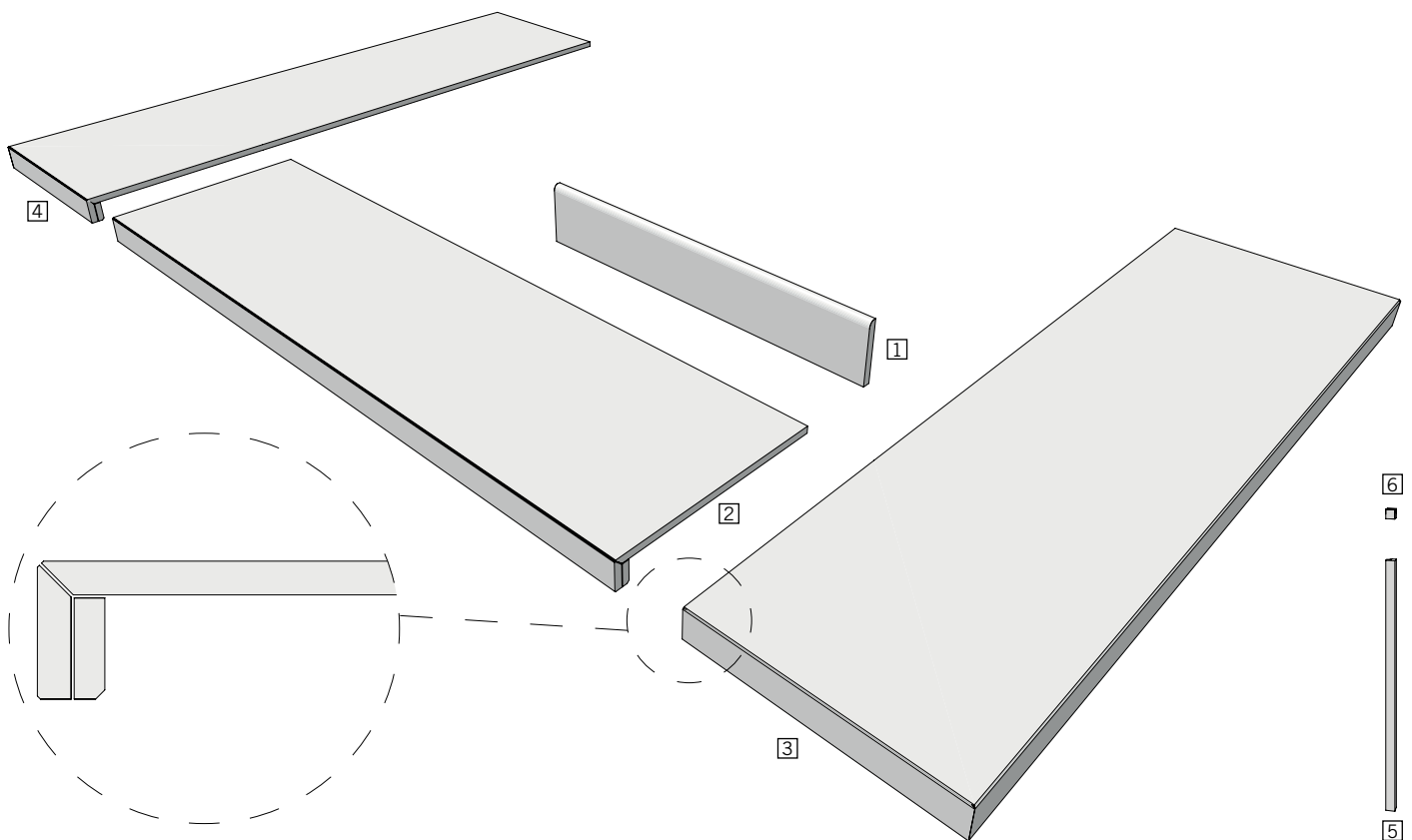

1 BATTISCOPA
10x60cm / 4"x24"
avorio
sabbia
caramel
brown

LGBARR5 0200
LGBARR6 0200
LGBARR7 0200
LGBARR8 0200

2 GRADINO PLUS rett.
35x120cm / 13 3/4"x48"
avorio
sabbia
caramel
brown

LG9ARPO 1985
LG9ARP1 1985
LG9ARP2 1985
LG9ARP3 1985

3 ANGOLO SX GRADINO PLUS
35x120cm / 13 3/4"x48"
avorio
sabbia
caramel
brown

LG9ARS0 2125
LG9ARS1 2125
LG9ARS2 2125
LG9ARS3 2125

4 ANGOLO DX GRADINO PLUS
35x120cm / 13 3/4"x48"
avorio
sabbia
caramel
brown

LG9ARDO 2125
LG9ARD1 2125
LG9ARD2 2125
LG9ARD3 2125

5 RACCORDO JOLLY
1,3x30cm / 1/2"x12"
avorio
sabbia
caramel
brown

LG9ARR5 0180
LG9ARR6 0180
LG9ARR7 0180
LG9ARR8 0180

6 BEAK JOLLY
1,3x1,3cm / 1/2"x1/2"
avorio
sabbia
caramel
brown

LG9ARB5 0260
LG9ARB6 0260
LG9ARB7 0260
LG9ARB8 0260

 Nocciola Manduria

 Bianco Leuca

 Beige Ostuni

 Strutturato*

30x60cm/12"x24"

60x60cm/24"x24"
60,4x60,4cm/24"x24"

37,5x75cm/15"x30"



75x75cm/30"x30"

*non trattato con antibatterico
 without antimicrobial treatment
 sans traitement antibacterien
 nicht mit antibakterieller
 Wirkung ausgestattet

Imballi pag. 433
 Packing
 Emballage
 Verpackung
 Embalajes
GRES TUTTA MASSA UGL
 Full-body porcelain
 Grès Cérame pleine masse
 Vollgemischtes Durchgefärbtes Feinsteinzeug
 Gres toda masa UGL
SPESSORE
 Thickness
 Epaisseur
 Stärke
 Espesor

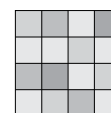
 10 mm (30x60 - 30x60,4 - 60x60 - 60,4x60,4)
 11 mm (37,5x75 - 75x75)
STONALIZZAZIONE
 Shading
 Denuançage
 Spielfarbig
 Grado de tonalización
**V3****FUGA MINIMA CONSIGLIATA**
 Minimum grout joint recommended
 Joint minimum conseillé
 Empfohlene Minimalfugenbreit
 Distancia recomendada entre las baldosas

 2 mm rettificato
 4 mm naturale
**RESISTENZA ALLO SCIVOLAMENTO
DIN 51130**
 Slip resistance
 Résistance au glissement
 Rutschfestigkeit
 Resistencia antideslizante

 R9 (bianco leuca / beige ostuni / nocciola manduria)
 R11 (strutturato)
**COEFFICIENTE DI ATTRITO DINAMICO
B.C.R. TORTUS**
 $\mu > 0,40$
**RESISTENZA ALLO SCIVOLAMENTO
DIN 51097**
 Slip resistance
 Résistance au glissement
 Rutschfestigkeit
 Resistencia antideslizante

classe C (strutturato)

**COEFFICIENT OF FRICTION
ASTM C1028**
 dry - COF ≥ 0.60
 wet - COF ≥ 0.60

ANTIBACTERIAL





salento beige ostuni 75x75cm / 30"x30" nat. rett.



salento strutturato 30x60,4cm / 12"x24" nat.



salento bianco leuca 37,5x75cm / 15"x30" nat. rett.

Salento formati e colori

sizes and colors / formats et de couleurs / formaten und farben / formatos y colores

nocciola manduria

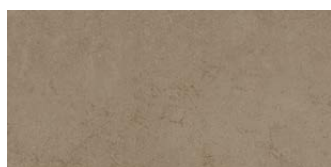

30x60cm / 12"x24"
nat. rett. (spessore 10mm) LGVS42R 1335
30x60,4cm / 12"x24"
nat. (spessore 10mm) LGVS420 1045

bianco leuca

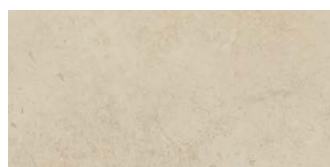

30x60cm / 12"x24"
nat. rett. (spessore 10mm) LGVS40R 1335
30x60,4cm / 12"x24"
nat. (spessore 10mm) LGVS400 1045

beige ostuni

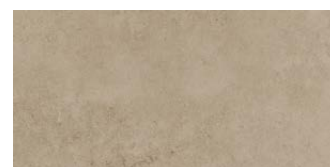

30x60cm / 12"x24"
nat. rett. (spessore 10mm) LGVS41R 1335
30x60,4cm / 12"x24"
nat. (spessore 10mm) LGVS410 1045



60x60cm / 24"x24"
nat. rett. (spessore 10mm) LGWS42R 1335
60,4x60,4cm / 24"x24"
nat. (spessore 10mm) LGWS420 1045



60x60cm / 24"x24"
nat. rett. (spessore 10mm) LGWS40R 1335
60,4x60,4cm / 24"x24"
nat. (spessore 10mm) LGWS400 1045



60x60cm / 24"x24"
nat. rett. (spessore 10mm) LGWS41R 1335
60,4x60,4cm / 24"x24"
nat. (spessore 10mm) LGWS410 1045

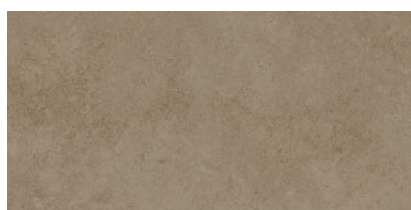

37,5x75cm / 15"x30"
nat. rett. (spessore 11mm) LGES42R 1435

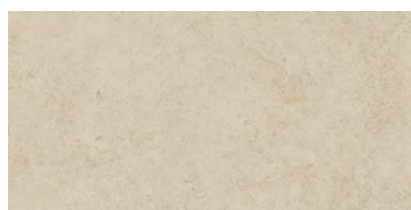

37,5x75cm / 15"x30"
nat. rett. (spessore 11mm) LGES40R 1435

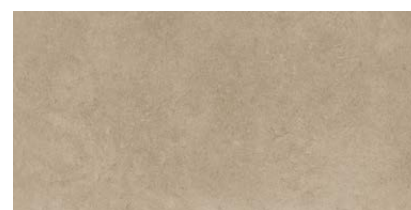

37,5x75cm / 15"x30"
nat. rett. (spessore 11mm) LGES41R 1435



75x75cm / 30"x30"
nat. rett. (spessore 11mm) LGOS42R 1435



75x75cm / 30"x30"
nat. rett. (spessore 11mm) LGOS40R 1435



75x75cm / 30"x30"
nat. rett. (spessore 11mm) LGOS41R 1435

***strutturato**



30x60cm / 12"x24"
nat. (spessore 10mm)

LGVS415 1045



60x60cm / 24"x24"
nat. rett. (spessore 10mm)

LGWS43R 1335

60,4x60,4cm / 24"x24"
nat. (spessore 10mm)

LGWS415 1045

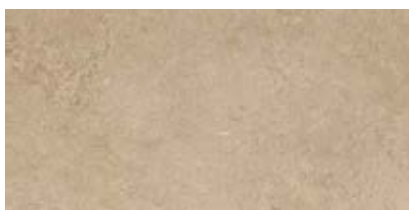

37,5x75cm / 15"x30"
nat. rett. (spessore 11mm)

LGES43R 1435



75x75cm / 30"x30"
nat. rett. (spessore 11mm)

LGOS43R 1435

*non trattato con antibatterico
without antimicrobial treatment
sans traitement antibacterien
nicht mit antibakterieller
Wirkung ausgestattet

Salento corredi e pezzi speciali

trims and decors / articles et pièces spéciales

formstücke und dekore / decorados y piezas especiales



MURETTO
nocciola manduria
30x60cm / 12"x24"

LG9S420 1950



MOSAICO
nocciola manduria
30x30cm / 12"x12"
LG9S425 1980



MOSAICO MATTONE
nocciola manduria
30x30cm / 12"x12"
LG9S42M 1980



MURETTO
bianco leuca
30x60cm / 12"x24"

LG9S400 1950



MOSAICO
bianco leuca
30x30cm / 12"x12"
LG9S405 1980



MOSAICO MATTONE
bianco leuca
30x30cm / 12"x12"
LG9S40M 1980



MURETTO
beige ostuni
30x60cm / 12"x24"

LG9S410 1950



MOSAICO
beige ostuni
30x30cm / 12"x12"
LG9S415 1980



MOSAICO MATTONE
beige ostuni
30x30cm / 12"x12"
LG9S41M 1980

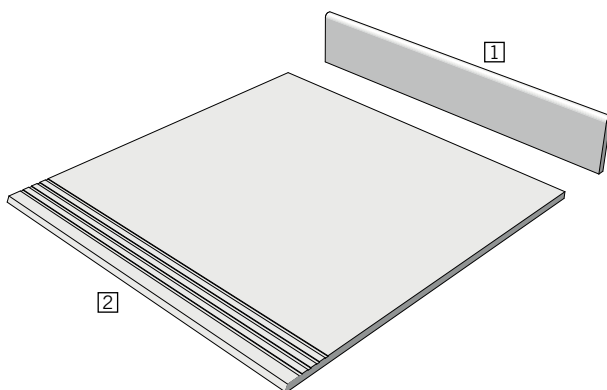

1 BATTISCOPA
10x60cm / 4"x24"
bianco leuca
nocciola manduria
beige ostuni
strutturato*

LGBS400 0200
LGBS420 0200
LGBS410 0200
LGBS41R 0200

2 GRADINO STEP
60x60cm / 24"x24"
bianco leuca
nocciola manduria
beige ostuni
strutturato*





LGCS400 0710
LGCS420 0710
LGCS410 0710
LGCS41R 0710

*non trattato con antibatterico
without antimicrobial treatment
sans traitement antibacterien
nicht mit antibakterieller
Wirkung ausgestattet

ANTIBACTERIAL



BLUE MOUNTAIN

-  Crystal Black
-  Ivory Black
-  Cinder Gray
-  Granite Gray



10x90cm/4"x36"



15x90cm/6"x36"



22,5x90cm/9"x36"



30x90cm/12"x36"



45x90cm/18"x36"



90x90cm/36"x36"



30x60cm/12"x24"

30x60,4cm/12"x24"

30x60,4cm/12"x24"

30x60,4cm/12"x24"



60x60cm/24"x24"

60,4x60,4cm/24"x24"

60,4x60,4cm/24"x24"

60,4x60,4cm/24"x24"

60,4x60,4cm/24"x24"

60,4x60,4cm/24"x24"

60,4x60,4cm/24"x24"

60,4x60,4cm/24"x24"

60,4x60,4cm/24"x24"

60,4x60,4cm/24"x24"

60,4x60,4cm/24"x24"

60,4x60,4cm/24"x24"

60,4x60,4cm/24"x24"

60,4x60,4cm/24"x24"

60,4x60,4cm/24"x24"

60,4x60,4cm/24"x24"

60,4x60,4cm/24"x24"

60,4x60,4cm/24"x24"

60,4x60,4cm/24"x24"

60,4x60,4cm/24"x24"

60,4x60,4cm/24"x24"

60,4x60,4cm/24"x24"

60,4x60,4cm/24"x24"

60,4x60,4cm/24"x24"

60,4x60,4cm/24"x24"

60,4x60,4cm/24"x24"

60,4x60,4cm/24"x24"

60,4x60,4cm/24"x24"

60,4x60,4cm/24"x24"

60,4x60,4cm/24"x24"

60,4x60,4cm/24"x24"

60,4x60,4cm/24"x24"

60,4x60,4cm/24"x24"

60,4x60,4cm/24"x24"

60,4x60,4cm/24"x24"

60,4x60,4cm/24"x24"

60,4x60,4cm/24"x24"

60,4x60,4cm/24"x24"

60,4x60,4cm/24"x24"

60,4x60,4cm/24"x24"

60,4x60,4cm/24"x24"

60,4x60,4cm/24"x24"

60,4x60,4cm/24"x24"

60,4x60,4cm/24"x24"

60,4x60,4cm/24"x24"

60,4x60,4cm/24"x24"

60,4x60,4cm/24"x24"

60,4x60,4cm/24"x24"

60,4x60,4cm/24"x24"

60,4x60,4cm/24"x24"

60,4x60,4cm/24"x24"

Imballi pag. 428

Packing
Emballage
Verpackung
Embalajes

GRES TUTTA MASSA UGL

Full-body porcelain
Grès Cérame pleine masse
Vollgemischtes Durchgefärbtes Feinsteinzeug
Gres toda masa UGL

FUGA MINIMA CONSIGLIATA

Minimum grout joint recommended
Joint minimum conseillé
Empfohlene Minimalfugenbreit
Distancia recomendada entre las baldosas

2 mm rettificato
4 mm naturale

RESISTENZA ALLO SCIVOLAMENTO DIN 51130

Slip resistance
Résistance au glissement
Rutschfestigkeit
Resistencia antideslizante

R9 (cinder gray / ivory black)
R11 (granite gray)

RESISTENZA ALLO SCIVOLAMENTO DIN 51097

Slip resistance
Résistance au glissement
Rutschfestigkeit
Resistencia antideslizante

classe C (granite gray)

SPESSORE

Thickness
Epaisseur
Stärke
Espesor

10 mm (30x60 - 30x60,4 - 60x60 - 60,4x60,4)
11 mm (37,5x75 - 75x75 - lato 90)

COEFFICIENTE DI ATTRITO DINAMICO B.C.R. TORTUS

$\mu > 0,40$
(cinder gray / ivory black / granite gray)

COEFFICIENT OF FRICTION ASTM C1028

dry - COF ≥ 0.60
wet - COF ≥ 0.60
(cinder gray / ivory black / granite gray)

STONALIZZAZIONE

Shading
Denuançage
Spielfarbig
Grado de tonalización

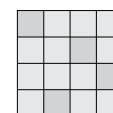

V2



blue mountain ivory black 90x90cm / 36"x36" nat. rett. - **blue mountain ivory black** 45x90cm / 18"x36" nat. rett.
blue mountain ivory black 75x75cm / 30"x30" nat. rett. - **blue mountain ivory black** 37,5x75cm / 15"x30" nat. rett.



blue mountain cinder gray 75x75cm / 30"x30" nat. rett.



blue mountain ivory black 90x90cm / 36"x36" nat. rett. - **blue mountain ivory black** 45x90cm / 18"x36" nat. rett.
blue mountain ivory black 75x75cm / 30"x30" nat. rett. - **blue mountain ivory black** 37,5x75cm / 15"x30" nat. rett.



blue mountain crystal black 90x90cm / 36"x36" nat. rett.

Blue Mountain formati e colori

sizes and colors / formats et couleurs / formaten und farben / formatos y colores

crystal black



10x90cm / 4"x36"
lapp. rett. (spessore 11mm)

LG7PP20 1735



15x90cm / 6"x36"
lapp. rett. (spessore 11mm)

LG7PP25 1735



22,5x90cm / 9"x36"
lapp. rett. (spessore 11mm)

LG3PP20 1735



30x90cm / 12"x36"
lapp. rett. (spessore 11mm)

LGFP20 1735

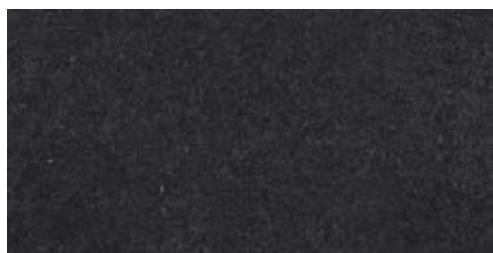

45x90cm / 18"x36"
lapp. rett. (spessore 11mm)

LGPP20 1745



37,5x75cm / 15"x30"
lapp. rett. (spessore 11mm)

LGEP2L 1555



30x60cm / 12"x24"
lapp. rett. (spessore 10mm) LGVPP2L 1505



90x90cm / 36"x36"
lapp. rett. (spessore 11mm)

LG9PP2L 1745



75x75cm / 30"x30"
lapp. rett. (spessore 11mm)

LGOPP2L 1555



60x60cm / 24"x24"
lapp. rett. (spessore 10mm) LGWPP2L 1505

ivory black

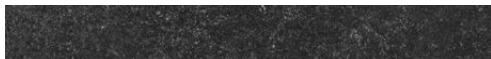

10x90cm / 4"x36"
nat. rett. (spessore 11mm)

LG7PP10 1690



15x90cm / 6"x36"
nat. rett. (spessore 11mm)

LG7PP15 1690



22,5x90cm / 9"x36"
nat. rett. (spessore 11mm)

LG3PP10 1690



30x90cm / 12"x36"
nat. rett. (spessore 11mm)

LGFP10 1690



45x90cm / 18"x36"
nat. rett. (spessore 11mm)

LGGPP10 1675

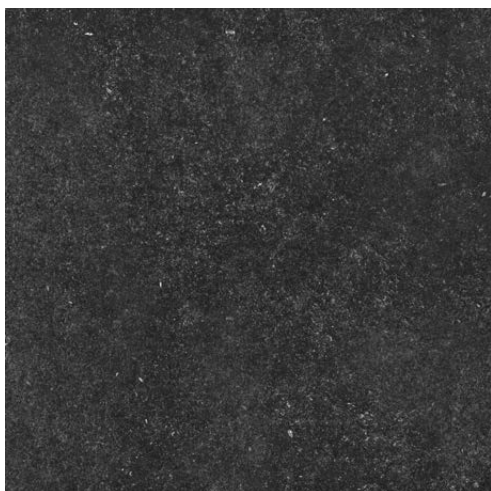

90x90cm / 36"x36"
nat. rett. (spessore 11mm)

LG9PP1R 1675



37,5x75cm / 15"x30"
nat. rett. (spessore 11mm)

LGEPP1R 1515

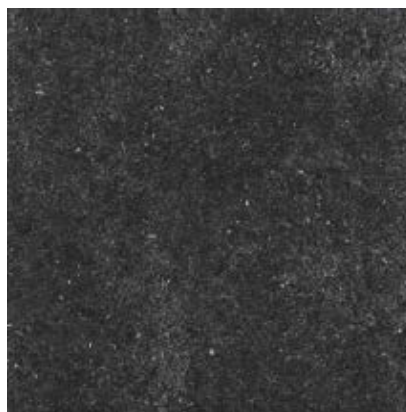

75x75cm / 30"x30"
nat. rett. (spessore 11mm)

LGOPPIR 1515



30x60cm / 12"x24"
nat. rett. (spessore 10mm)

LGVPP1R 1425

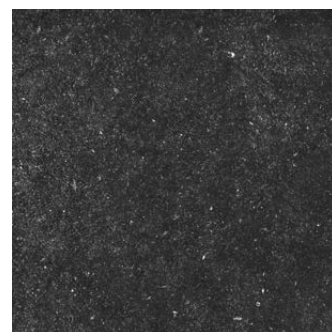

60x60cm / 24"x24"
nat. rett. (spessore 10mm)

LGWPP1R 1425

Blue Mountain formati e colori

sizes and colors / formats et couleurs / formaten und farben / formatos y colores

cinder gray



10x90cm / 4"x36"
nat. rett. (spessore 11mm)

LG7PP00 1690



15x90cm / 6"x36"
nat. rett. (spessore 11mm)

LG7PP05 1690

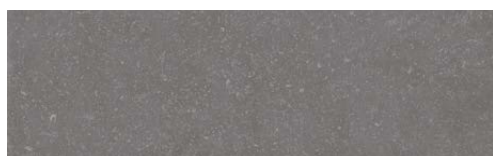

22,5x90cm / 9"x36"
nat. rett. (spessore 11mm)

LG3PP00 1690



30x90cm / 12"x36"
nat. rett. (spessore 11mm)

LGFP00 1690



45x90cm / 18"x36"
nat. rett. (spessore 11mm)

LGGPP00 1675

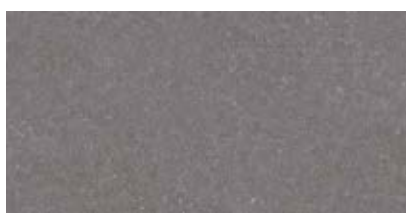

37,5x75cm / 15"x30"
nat. rett. (spessore 11mm)

LGEP00R 1515



30x60cm / 12"x24"
nat. rett. (spessore 10mm) LGVPP0R 1425



90x90cm / 36"x36"
nat. rett. (spessore 11mm)

LG9PP0R 1675



75x75cm / 30"x30"
nat. rett. (spessore 11mm)

LGOPP0R 1515

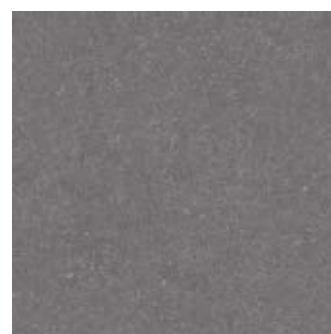

60x60cm / 24"x24"
nat. rett. (spessore 10mm) LGWPP0R 1425

granite gray



37,5x75cm / 15"x30"
nat. rett. (spessore 11mm)

LGEP3R 1515



30x60,4cm / 12"x24"
nat. (spessore 10mm)

LGVP30 1055

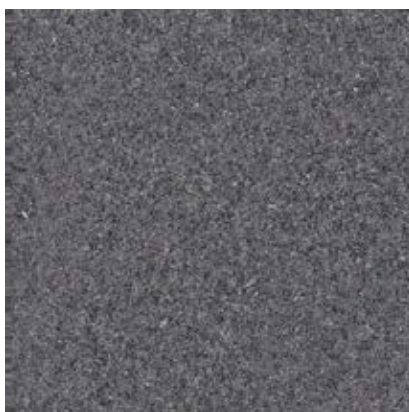

75x75cm / 30"x30"
nat. rett. (spessore 11mm)

LGOPP3R 1515



60x60cm / 24"x24"
nat. rett. (spessore 10mm)
60,4x60,4cm / 24"x24"
nat. (spessore 10mm)

LGWPP3R 1425

LGWPP30 1055

Blue Mountain corredi e pezzi speciali

trims and decors / articles et pièces spéciales

formstücke und dekore / decorados y piezas especiales



MURETTO
crystal black
30x60cm / 12"x24"

LG9PPM2 0720



MOSAICO
crystal black
30x30cm / 12"x12"
LG9PP25 2020

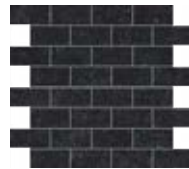

MOSAICO MATTONE
crystal black
30x30cm / 12"x12"
LG9PP2M 2020



MURETTO
ivory black
30x60cm / 12"x24"

LG9PPM1 0690



MOSAICO
ivory black
30x30cm / 12"x12"
LG9PP15 1980



MOSAICO MATTONE
ivory black
30x30cm / 12"x12"
LG9PP1M 1980



MURETTO
cinder gray
30x60cm / 12"x24"

LG9PPM0 0690

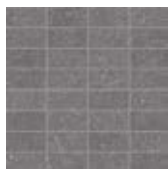

MOSAICO
cinder gray
30x30cm / 12"x12"
LG9PP05 1980

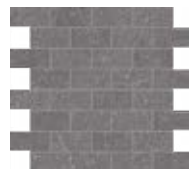

MOSAICO MATTONE
cinder gray
30x30cm / 12"x12"
LG9PP0M 1980

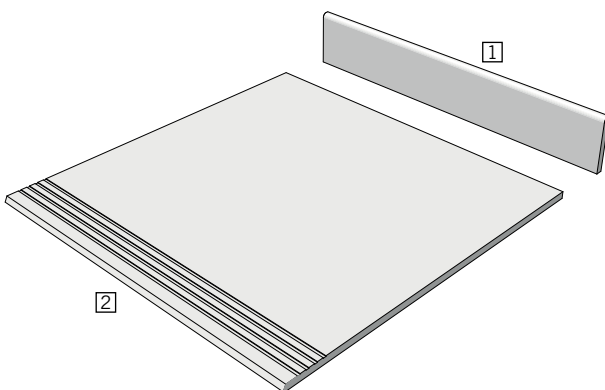

1 BATTISCOPA
10x60cm / 4"x24"
cinder gray
ivory black
crystal black
granite gray

LGBPP0 0200
LGBPP10 0200
LGBPP20 0250
LGBPP30 0200

2 GRADINO STEP
60x60cm / 24"x24"
cinder gray
ivory black
crystal black
granite gray

LGCPP00 0920
LGCPP10 0920
LGCPP20 0990
LGCPP30 0920



BASALTINA STONE PROJECT

-  Sabbciata
-  Sabbciata Velvet
-  Naturale
-  Stuccata
-  Lappata
-  Levigata
-  Scalpellata
-  Texture



30x60cm/12"x24"

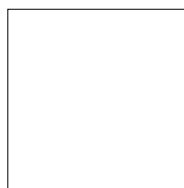

60x60cm/24"x24"

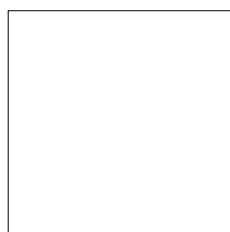

75x75cm/30"x30"



60x120cm/24"x48"

Imballi pag. 426
 Packing
 Emballage
 Verpackung
 Embalajes

GRES TUTTA MASSA UGL

Full-body porcelain
 Grès Cérame pleine masse
 Vollgemischtes Durchgefärbtes Feinsteinzeug
 Gres toda masa UGL

SPESSORE

Thickness
 Epaisseur
 Stärke
 Espesor

11 mm (30x60 - 60x60 - 75x75)
 12 mm (60x120)

STONALIZZAZIONE

Shading
 Denuançage
 Spielfarbig
 Grado de tonalización

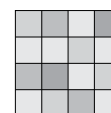

V3

FUGA MINIMA CONSIGLIATA

Minimum grout joint recommended
 Joint minimum conseillé
 Empfohlene Minimalfugenbreit
 Distancia recomendada entre las baldosas
 2 mm

RETTIFICATO MONOCALIBRO

Single caliber rectified
 Monocalibre réctifié
 Monokaliber rectifiziert
 Rectificado monocalibre



IT / 021 / 010

RESISTENZA ALLO SCIVOLAMENTO DIN 51130

Slip resistance
 Résistance au glissement
 Rutschfestigkeit
 Resistencia antideslizante

R10 (naturale/stuccata/texture naturale/
 sabbciata velvet)
 R11 (sabbciata/scalpellata)

COEFFICIENTE DI ATTRITO DINAMICO B.C.R. TORTUS

$\mu > 0,40$
 (sabbciata/sabbciata velvet/scalpellata/naturale/
 stuccata/texture naturale)

COEFFICIENT OF FRICTION ASTM C1028

dry - COF ≥ 0.60
 wet - COF ≥ 0.60
 (sabbciata/sabbciata velvet/scalpellata/naturale/
 stuccata/texture naturale)

BRITISH PENDULUM TEST BS 7976:2002

4S (slider 96)
 dry: low slip potential PTV 36+ (naturale/stuccata/
 sabbciata velvet/sabbciata/scalpellata)
 wet: moderate slip potential PTV 25-35 (naturale/
 stuccata/sabbciata velvet)
 low slip potential PTV 36+ (sabbciata/scalpellata)
 TRL (slider 55)
 dry: low slip potential PTV 36+ (sabbciata/scalpellata)
 wet: low slip potential PTV 36+ (sabbciata/scalpellata)

RESISTENZA ALLO SCIVOLAMENTO DIN 51097

Slip resistance
 Résistance au glissement
 Rutschfestigkeit
 Resistencia antideslizante
 classe C (sabbciata/scalpellata)

DYNAMIC COEFFICIENT OF FRICTION BOT 3000

DCOF ≥ 0.42 (naturale/stuccata/sabbciata velvet)
 DCOF ≥ 0.62 (sabbciata/scalpellata)

WET PENDULUM TEST AS/NZS 4586:2004

class W (sabbciata/scalpellata)



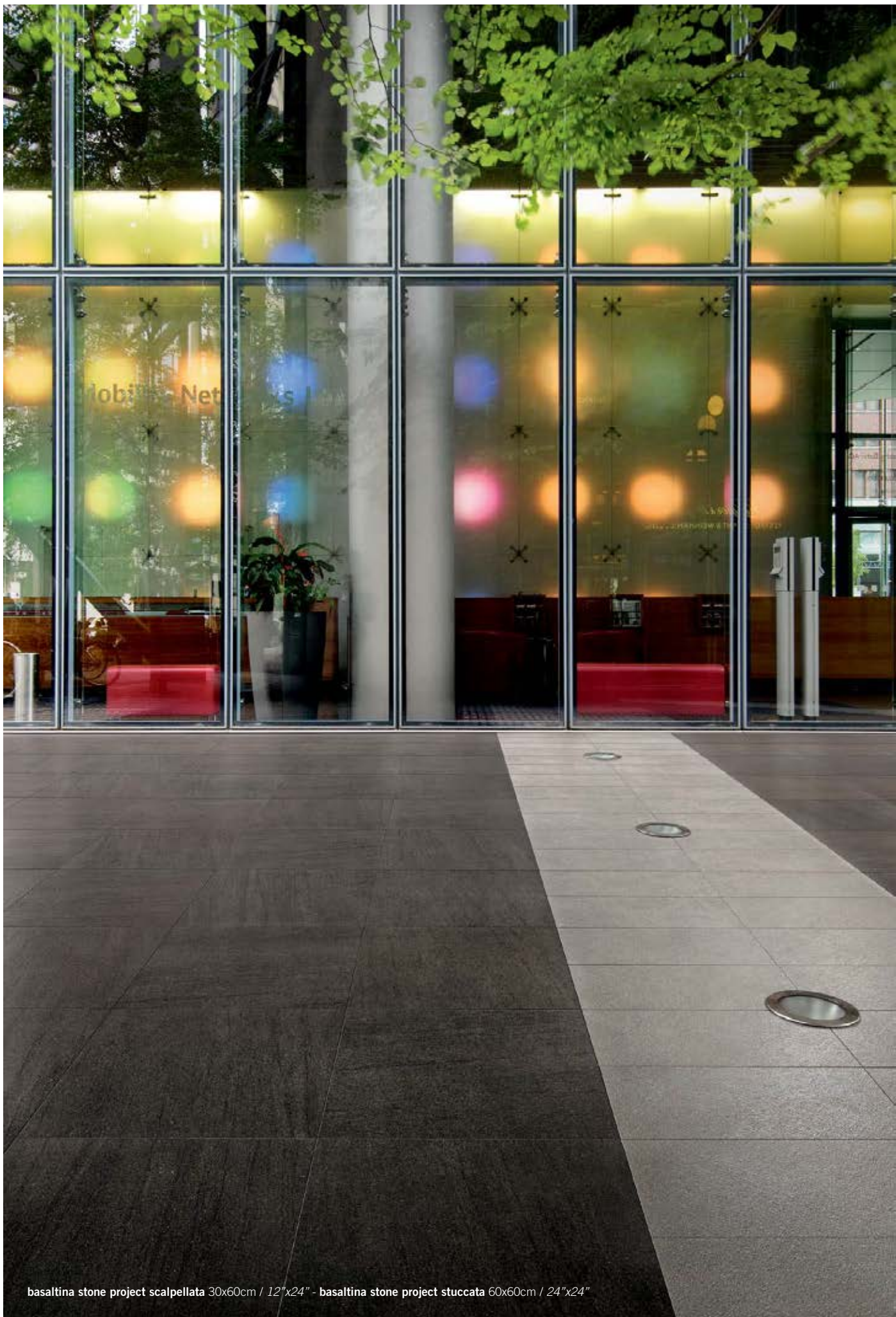

basaltina stone project scalpellata 30x60cm / 12"x24" - basaltina stone project stuccata 60x60cm / 24"x24"

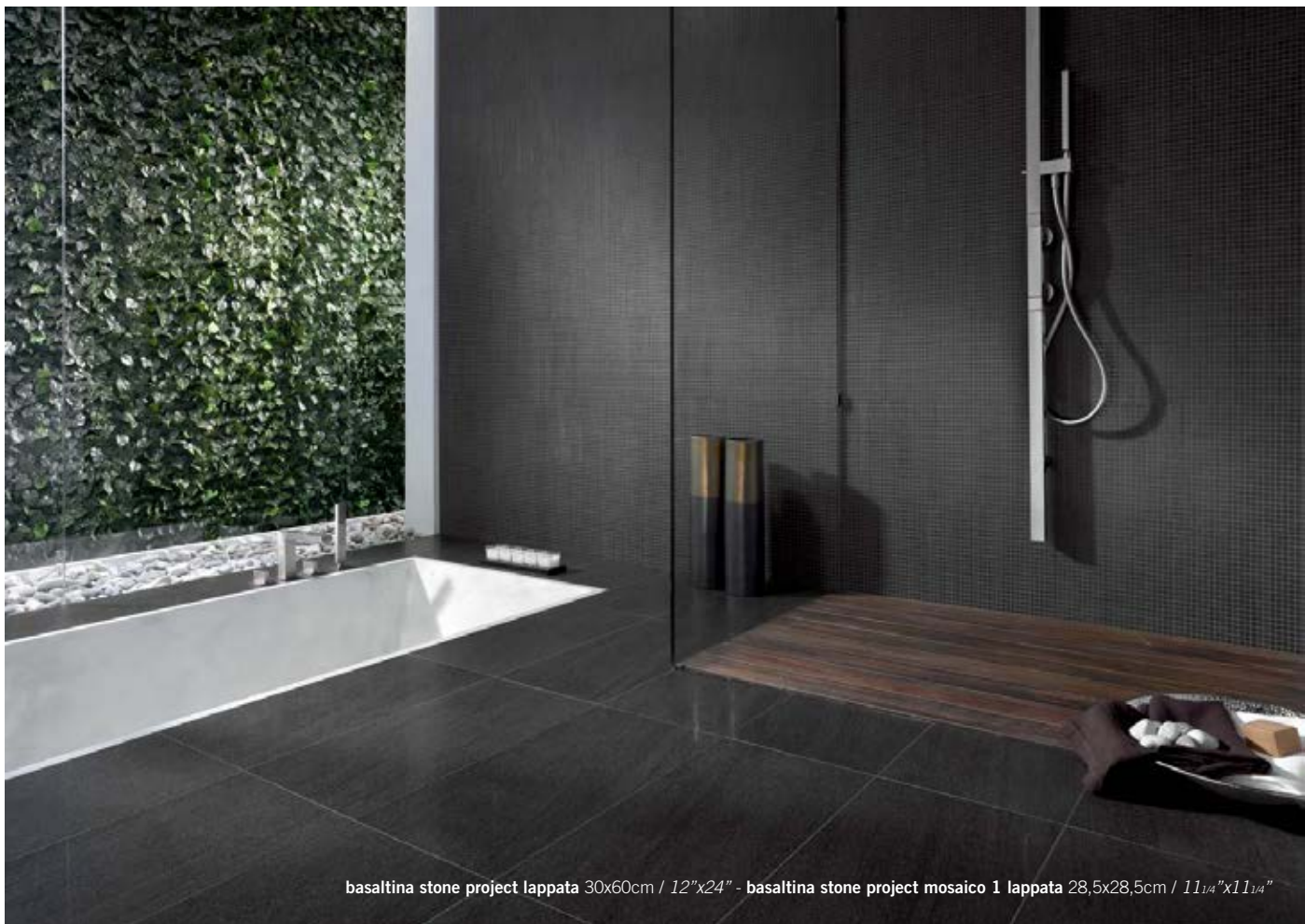

basaltina stone project lappata 30x60cm / 12"x24" - basaltina stone project mosaico 1 lappata 28,5x28,5cm / 11¹/₄"x11¹/₄"



basaltina stone project naturale 30x60cm / 12"x24" - basaltina stone project sabbia 60x60cm / 24"x24"

Basaltina Stone Project formati e colori

sizes and colors / formats et couleurs / formaten und farben / formatos y colores

levigata

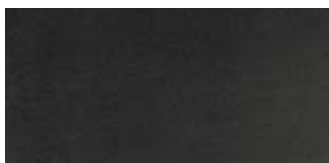

30x60cm / 12"x24"
rett. (spessore 11mm)

LGVBSL4 1510



60x60cm / 24"x24"
rett. (spessore 11mm)

LGWBSL4 1510

lappata



30x60cm / 12"x24"
rett. (spessore 11mm)

LGVBSL3 1420



60x60cm / 24"x24"
rett. (spessore 11mm)

LGWBSL3 1420



75x75cm / 30"x30"
rett. (spessore 11mm)

LG OBS3R 1540



60x120cm / 24"x48"
rett. (spessore 12mm)

LGXBSRD 1780

stuccata



30x60cm / 12"x24"
rett. (spessore 11mm)

LGVBSR2 1330



60x60cm / 24"x24"
rett. (spessore 11mm)

LGWBSR2 1330



75x75cm / 30"x30"
rett. (spessore 11mm)

LGOBS2R 1510



60x120cm / 24"x48"
rett. (spessore 12mm)

LGXBSRC 1720

naturale



30x60cm / 12"x24"
rett. (spessore 11mm)

LGVBSR1 1330



60x60cm / 24"x24"
rett. (spessore 11mm)

LGWBSR1 1330



75x75cm / 30"x30"
rett. (spessore 11mm)

LGOBSIR 1510

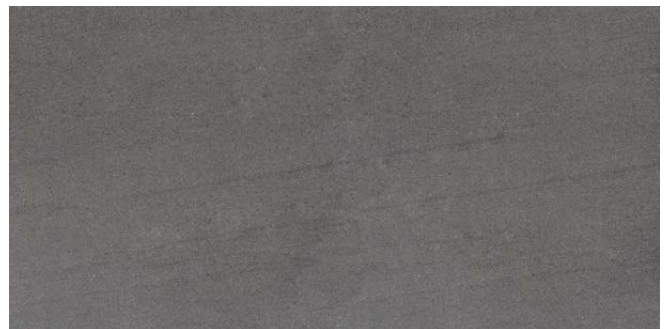

60x120cm / 24"x48"
rett. (spessore 12mm)

LGXBSRB 1720

Basaltina Stone Project formati e colori

sizes and colors / formats et couleurs / formaten und farben / formatos y colores

sabbiata

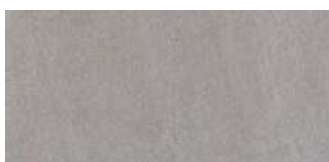

30x60cm / 12"x24"
rett. (spessore 11mm)

LGVBRS0 1290



60x60cm / 24"x24"
rett. (spessore 11mm)

LGWBSR0 1290

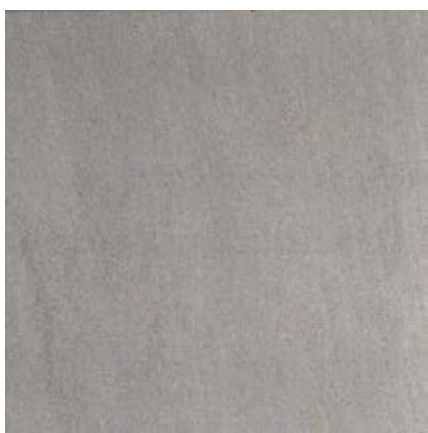

75x75cm / 30"x30"
rett. (spessore 11mm)

LGOBSOR 1510



60x120cm / 24"x48"
rett. (spessore 12mm)

LGXBSRA 1720

sabbiata velvet

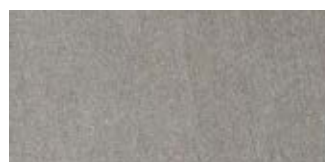

30x60cm / 12"x24"
rett. (spessore 11mm)

LGVBRSRE 1290



60x60cm / 24"x24"
rett. (spessore 11mm)

LGWBSRE 1290



75x75cm / 30"x30"
rett. (spessore 11mm)

LGOBSRO 1510



60x120cm / 24"x48"
rett. (spessore 12mm)

LGXBSRE 1720

texture



30x60cm / 12"x24"
nat. rett. (spessore 11mm) LGVBSR7 1330
lev. rett. (spessore 11mm) LGVBSL7 1420



60x60cm / 24"x24"
nat. rett. (spessore 11mm) LGWBSR7 1330
lev. rett. (spessore 11mm) LGWBSL7 1420

scalpellata

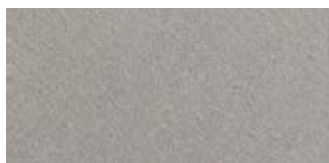

30x60cm / 12"x24"
rett. (spessore 11mm) LGVBSR6 1290



60x60cm / 24"x24"
rett. (spessore 11mm) LGWBSR6 1290

Basaltina Stone Project corredi

decors / decors / dekore / decoros

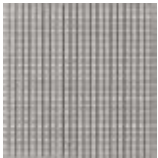

MOSAICO 1
sabbiata
28,5x28,5cm / 11¼"x11¼"
LG9BS00 [0440](#)



MURETTO
sabbiata
30x60cm / 12"x24"
LG9BS05 [0690](#)

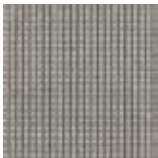

MOSAICO 1
sabbiata velvet
28,5x28,5cm / 11¼"x11¼"
LG9BS19 [0440](#)



MURETTO
sabbiata velvet
30x60cm / 12"x24"
LG9BS49 [0690](#)

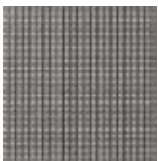

MOSAICO 1
naturale
28,5x28,5cm / 11¼"x11¼"
LG9BS01 [0440](#)



MURETTO
naturale
30x60cm / 12"x24"
LG9BS06 [0690](#)

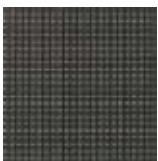

MOSAICO 1
stuccata
28,5x28,5cm / 11¼"x11¼"
LG9BS02 [0440](#)



MURETTO
stuccata
30x60cm / 12"x24"
LG9BS07 [0690](#)



MOSAICO 1
lappata
28,5x28,5cm / 11¼"x11¼"
LG9BS03 [0440](#)



MURETTO
lappata
30x60cm / 12"x24"
LG9BS08 [0690](#)

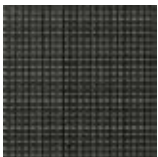

MOSAICO 1
levigata
28,5x28,5cm / 11¼"x11¼"
LG9BS04 [0440](#)



MURETTO
levigata
30x60cm / 12"x24"
LG9BS09 [0690](#)

Basaltina Stone Project pezzi speciali

trims / pièces spéciales / formstücke / piezas especiales

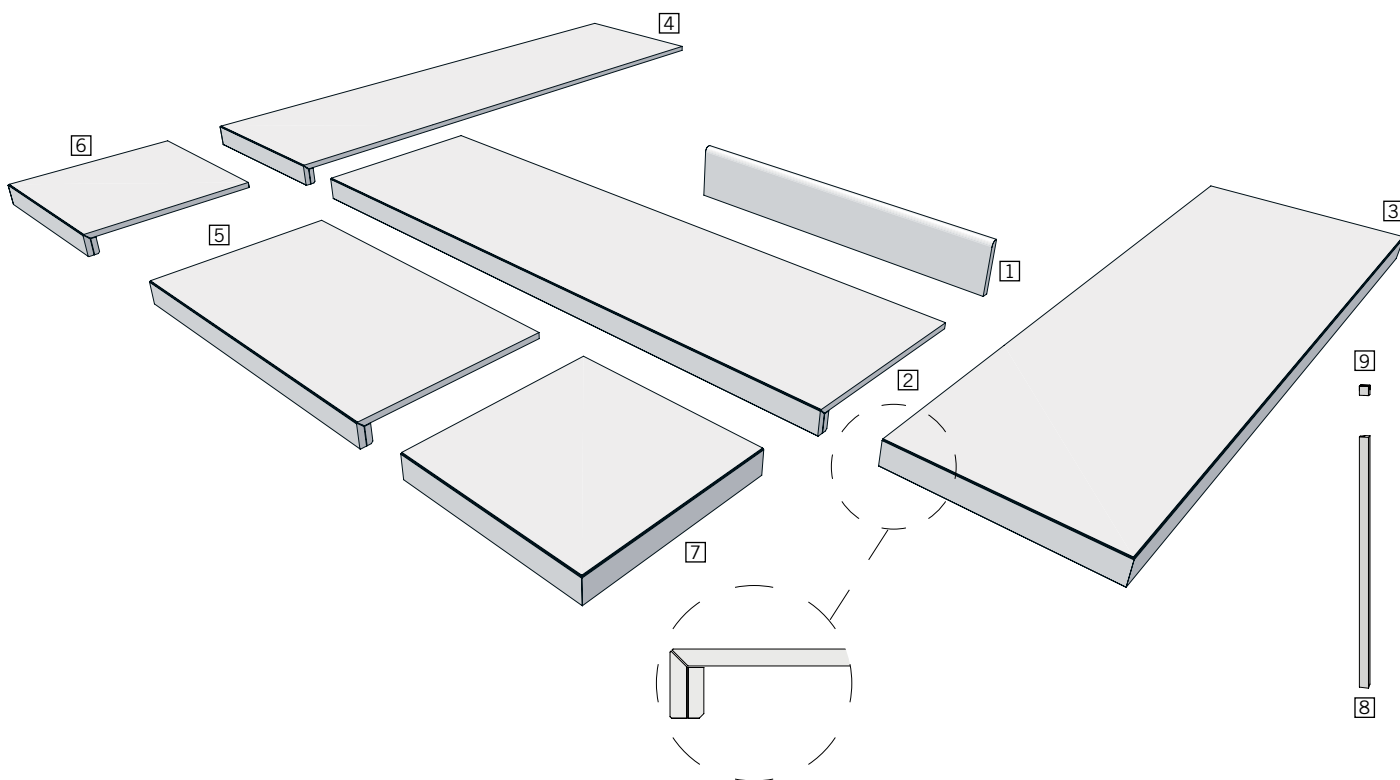

1 BATTISCOPIA

10x60cm / 4"x24"

sabbiaia
sabbiaia velvet
naturale
stuccata
scalpellata
texture nat.
lappata
levigata
texture lev.

LG9BSR0 0170
LG9BSR1 0170
LG9BSR2 0170
LG9BSR3 0250
LG9BSR4 0250
LG9BSR5 0170
LG9BSR6 0170
LG9BSR7 0170
LG9BSR8 0250
LG9BSR9 0250
LG9BSL7 0250

2 GRADINO PLUS

35x120cm / 13 3/4"x48"

sabbiaia
sabbiaia velvet
naturale
stuccata
lappata

LG9BSP0 1985
LG9BSP1 1985
LG9BSP2 1985
LG9BSP3 1985

3 ANGOLO SX GRADINO PLUS

35x120cm / 13 3/4"x48"

sabbiaia
sabbiaia velvet
naturale
stuccata
lappata

LG9BSS0 2125
LG9BSS1 2125
LG9BSS2 2125
LG9BSS3 2125

4 ANGOLO DX GRADINO PLUS

35x120cm / 13 3/4"x48"

sabbiaia
sabbiaia velvet
naturale
stuccata
lappata

LG9BSD0 2125
LG9BSD1 2125
LG9BSD2 2125
LG9BSD3 2125

5 GRADINO PLUS

35x60cm / 13 3/4"x24"

texture nat.
texture lev.
scalpellata
levigata

LG9BSX7 1630
LG9BSX8 1630
LG9BSX9 1630
LG9BSX4 1760

6 ANGOLO SX GRADINO PLUS

35x35cm / 13 3/4"x13 3/4"

texture nat.
texture lev.
scalpellata
levigata

LG9BSZ7 1970
LG9BSZ8 1970
LG9BSZ9 1970
LG9BSZ4 1990

7 ANGOLO DX GRADINO PLUS

35x35cm / 13 3/4"x13 3/4"

texture nat.
texture lev.
scalpellata
levigata

LG9BSY7 1970
LG9BSY8 1970
LG9BSY9 1970
LG9BSY4 1190

8 RACCORDO JOLLY

1,3x30cm / 1/2"x12"

sabbiaia
sabbiaia velvet
naturale
stuccata
lappata
levigata
scalpellata
texture lev.
texture nat.

LG9BS31 0180
LG9BS32 0180
LG9BS33 0180
LG9BS34 0180
LG9BS35 0180
LG9BS36 0180
LG9BS37 0180
LG9BS38 0180

9 BEAK JOLLY

1,3x1,3cm / 1/2"x1/2"

sabbiaia
sabbiaia velvet
naturale
stuccata
lappata
levigata
scalpellata
texture lev.
texture nat.

LG9BS40 0260
LG9BS41 0260
LG9BS42 0260
LG9BS43 0260
LG9BS44 0260
LG9BS45 0260
LG9BS46 0260
LG9BS47 0260
LG9BS48 0260

MAKÒ

 Papiro Bianco	 2x2cm/3/4"x3/4"
 Linen Beige	 2x60cm/3/4"x24"
 Cedar Bruno	 9,7x60cm/3/4"x24"
 Yucca Grigio	 30x60cm/12"x24"
 Java Scuro	 60x60cm/24"x24"

Imballi pag. 430
Packing
Emballage
Verpackung
Embalajes

GRES SMALTATO A MASSA COLORATA GL

Colored-body glazed porcelain
Grès émaillé à masse colorée
Glasiertes Feisteinzeug mit farbiger Masse
Gres esmaltado de masa colorada GL

SPESSORE

Thickness
Epaisseur
Stärke
Espesor
11 mm

STONALIZZAZIONE

Shading
Denuançage
Spielfarbig
Grado de tonalización

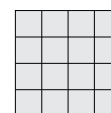

V1

FUGA MINIMA CONSIGLIATA

Minimum grout joint recommended
Joint minimum conseillé
Empfohlene Minimalfugenbreite
Distancia recomendada entre las baldosas
2 mm

RETTIFICATO MONOCALIBRO

Single caliber rectified
Monocalibre réctifié
Monokaliber rectifiziert
Rectificado monocalibre

RESISTENZA ALLO SCIVOLAMENTO DIN 51130

Slip resistance
Résistance au glissement
Rutschfestigkeit
Resistencia antideslizante
R9

COEFFICIENTE DI ATTRITO DINAMICO B.C.R. TORTUS

$\mu > 0,40$

RESISTENZA ALL'ABRASIONE SUPERFICIALE ISO 10545-7

Resistance to superficial abrasion
Résistance à l'abrasion superficielle
Oberflächliche reibungsbeständigkeit
Resistencia a la abrasión superficial
pei 5 (papiro bianco/linen beige/yucca grigio)
pei 4 (cedar bruno/java scuro)

COEFFICIENT OF FRICTION ASTM C1028

dry - COF ≥ 0.60
wet - COF ≥ 0.60



makò papiro bianco 2x60cm / 3/4"x24" - makò papiro bianco 9,7x60cm / 3³/₄"x24"
makò papiro bianco 60x60cm / 24"x24" - makò decoro wallpaper grey 20x60cm / 8"x24"



makò yucca grigio 30x60cm / 12"x24" - makò yucca grigio 60x60cm / 24"x24"
makò decoro pin striped 30x60cm / 12"x24" - makò decoro corset 30x30cm / 12"x12"
makò fascia twill cold 3x60cm / 1x16"x24"



makò papiro bianco 60x60cm / 24"x24" - makò beige decoro cross 30x60cm / 12"x24"



makò cedar bruno 30x60cm / 12"x24" - makò cedar bruno decoro tartan 30x60cm / 12"x24"
makò papiro bianco 60x60cm / 24"x24"

Makò formati e colori

sizes and colors / formats et couleurs / formaten und farben / formatos y colores

papiro bianco



2x2cm / 3/4"x3/4"
rett. LG9MK35 0010



2x60cm / 3/4"x24"
rett. LG9MK30 0040



9,7x60cm / 3 3/4"x24"
rett. LG9MK00 0210



30x60cm / 12"x24"
rett. LGVMKRO 1120



60x60cm / 24"x24"
rett. LGWMKRO 1120

linen beige



2x2cm / 3/4"x3/4"
rett. LG9MK36 0010



2x60cm / 3/4"x24"
rett. LG9MK31 0040



9,7x60cm / 3 3/4"x24"
rett. LG9MK01 0210



30x60cm / 12"x24"
rett. LGVMKR1 1120



60x60cm / 24"x24"
rett. LGWMKR1 1120

yucca grigio



2x2cm / 3/4"x3/4"
rett. LG9MK37 0010



2x60cm / 3/4"x24"
rett. LG9MK32 0040



9,7x60cm / 3 3/4"x24"
rett. LG9MK02 0210



30x60cm / 12"x24"
rett. LGVMKR2 1120



60x60cm / 24"x24"
rett. LGWMKR2 1120

cedar bruno



2x2cm / 3/4"x3/4"
rett. LG9MK38 0010



2x60cm / 3/4"x24"
rett. LG9MK33 0040



9,7x60cm / 3^{3/4}"x24"
rett. LG9MK03 0210



30x60cm / 12"x24"
rett. LGVMKR3 1120



60x60cm / 24"x24"
rett. LGWMKR3 1120

java scuro



2x2cm / 3/4"x3/4"
rett. LG9MK39 0010



2x60cm / 3/4"x24"
rett. LG9MK34 0040



9,7x60cm / 3^{3/4}"x24"
rett. LG9MK04 0210



30x60cm / 12"x24"
rett. LGVMKR4 1120



60x60cm / 24"x24"
rett. LGWMKR4 1120

Makò corredi e pezzi speciali

trims and decors / articles et pièces spéciales

formstücke und dekore / decorados y piezas especiales



DECORO PIN STRIPED

papiro bianco

30x60cm / 12"x24"

LG9MK23 [0880](#)



DECORO CORSET

papiro bianco

30x30cm / 12"x12"

LG9MK16 [0210](#)



DECORO TARTAN

cedar bruno

30x60cm / 12"x24"

LG9MK13 [0620](#)



DECORO PIN STRIPED

linen beige

30x60cm / 12"x24"

LG9MK24 [0880](#)



DECORO CORSET

linen beige

30x30cm / 12"x12"

LG9MK17 [0210](#)



DECORO TARTAN

java scuro

30x60cm / 12"x24"

LG9MK12 [0620](#)



DECORO PIN STRIPED

yucca grigio

30x60cm / 12"x24"

LG9MK25 [0880](#)



DECORO CORSET

yucca grigio

30x30cm / 12"x12"

LG9MK18 [0210](#)



DECORO PIN STRIPED

cedar bruno

30x60cm / 12"x24"

LG9MK27 [0880](#)



DECORO CORSET

cedar bruno

30x30cm / 12"x12"

LG9MK20 [0210](#)



DECORO CROSS

linen beige

30x60cm / 12"x24"

LG9MK10 [0740](#)

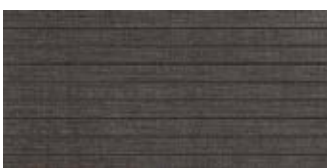

DECORO PIN STRIPED

java scuro

30x60cm / 12"x24"

LG9MK26 [0880](#)



DECORO CORSET

java scuro

30x30cm / 12"x12"

LG9MK19 [0210](#)



DECORO CROSS

yucca grigio

30x60cm / 12"x24"

LG9MK11 [0740](#)



DECORO WALLPAPER

beige
20x60cm / 8"x24" LG9MK15 [0620](#)



DECORO WALLFLOWER

30x60cm / 12"x24"
cedar bruno LG9MK09 [0620](#)
papiro bianco LG9MK05 [0620](#)
linen beige LG9MK06 [0620](#)
yucca grigio LG9MK07 [0620](#)
java scuro LG9MK08 [0620](#)



DECORO WALLPAPER

grey
20x60cm / 8"x24" LG9MK14 [0620](#)



FASCIA TWILL

cold
3x60cm / 1 3/16"x24" LG9MK41 [0550](#)



FASCIA TWILL

warm
3x60cm / 1 3/16"x24" LG9MK40 [0450](#)



FASCIA BROCADE

cold
3x60cm / 1 3/16"x24" LG9MK22 [0430](#)



FASCIA BROCADE

warm
3x60cm / 1 3/16"x24" LG9MK21 [0430](#)

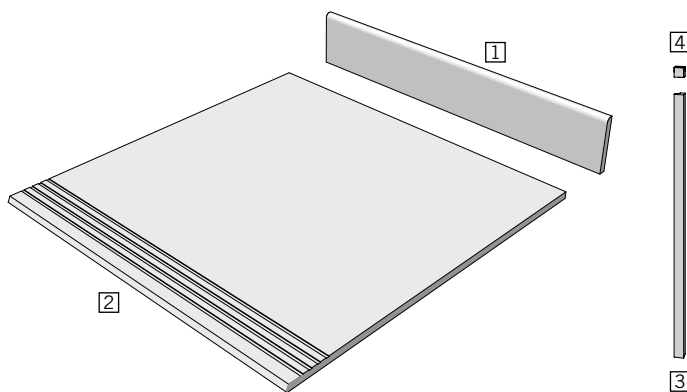

1 BATTISCOPA
10x60cm / 4"x24"
papiro bianco
linen beige
yucca grigio
cedar bruno
java scuro

LGBMK00 [0120](#)
LGBMK10 [0120](#)
LGBMK20 [0120](#)
LGBMK30 [0120](#)
LGBMK40 [0120](#)

2 GRADINO STEP
60x60cm / 24"x24"
papiro bianco
linen beige
yucca grigio
cedar bruno
java scuro

LGCMKR0 [0610](#)
LGCMKR1 [0610](#)
LGCMKR2 [0610](#)
LGCMKR3 [0610](#)
LGCMKR4 [0610](#)

3 RACCORDO JOLLY
1,3x30cm / 1/2"x12"
papiro bianco
linen beige
yucca grigio
cedar bruno
java scuro

LG9MK42 [0180](#)
LG9MK43 [0180](#)
LG9MK44 [0180](#)
LG9MK45 [0180](#)
LG9MK46 [0180](#)

4 BEAK JOLLY
1,3x1,3cm / 1/2"x1/2"
papiro bianco
linen beige
yucca grigio
cedar bruno
java scuro

LG9MK47 [0230](#)
LG9MK48 [0230](#)
LG9MK49 [0230](#)
LG9MK50 [0230](#)
LG9MK51 [0230](#)

STONEHENGE

 Grafite

5,7x60cm/2^{1/4}"x24"

 Antracite

9,7x60cm/3^{3/4}"x24"

 Savanna

30x60cm/12"x24"

 Cardoso

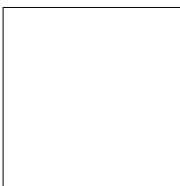
60x60cm/24"x24"

75x75cm/30"x30"

Imballi pag. 434
Packing
Emballage
Verpackung
Embalajes

GRES TUTTA MASSA UGL

Full-body porcelain
Grès Cérame pleine masse
Vollgemischtes Durchgefärbtes Feinsteinzeug
Gres toda masa UGL

SPESSORE

Thickness
Epaisseur
Stärke
Espesor
11 mm

STONALIZZAZIONE

Shading
Denuançage
Spielfarbig
Grado de tonalización

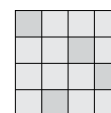

V2

FUGA MINIMA CONSIGLIATA

Minimum grout joint recommended
Joint minimum conseillé
Empfohlene Minimalfugenbreit
Distancia recomendada entre las baldosas

2 mm rettificato
4 mm naturale

RESISTENZA ALLO SCIVOLAMENTO DIN 51130

Slip resistance
Résistance au glissement
Rutschfestigkeit
Resistencia antideslizante

R10
grafite (naturale) - antracite (naturale) - cardoso (naturale)

COEFFICIENTE DI ATTRITO DINAMICO B.C.R. TORTUS

$\mu > 0,40$
grafite (naturale) - antracite (naturale)
cardoso (naturale)

RESISTENZA ALLO SCIVOLAMENTO DIN 51097

Slip resistance
Résistance au glissement
Rutschfestigkeit
Resistencia antideslizante

classe A
antracite (naturale) - cardoso (naturale) - grafite (naturale)

COEFFICIENT OF FRICTION ASTM C1028

dry - COF ≥ 0.60
wet - COF ≥ 0.60
grafite (naturale) - antracite (naturale)
cardoso (naturale)



IT / 021 / 010



stonehenge grafite 30x60cm / 12"x24" lapp. - stonehenge grafite lapp. 60x60cm / 24"x24" lapp.
stonehenge composizione listello grafite lapp. 30x30cm / 12"x12" lapp.

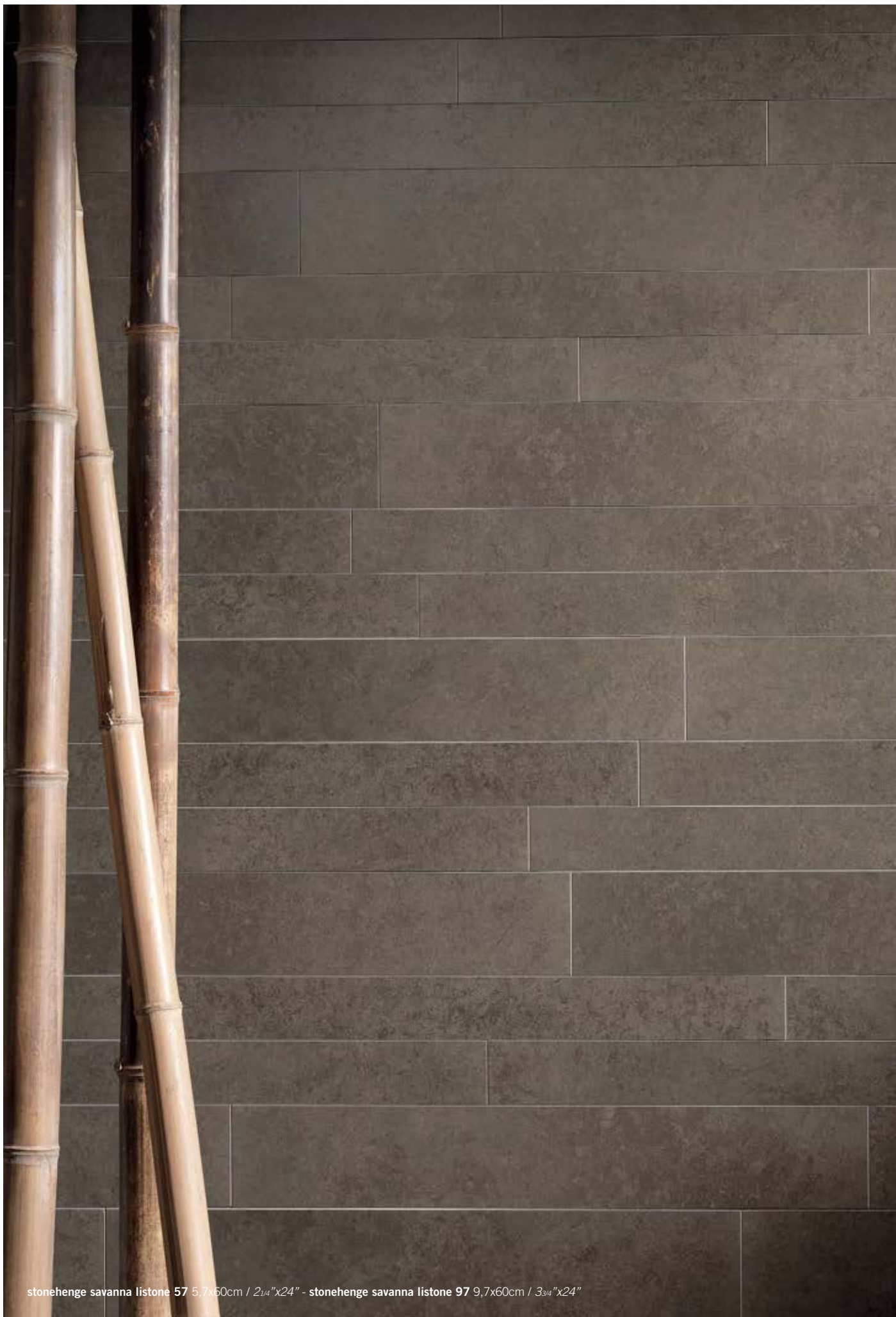

stonehenge savanna listone 57 5,7x60cm / 2¹/₄"x24" - stonehenge savanna listone 97 9,7x60cm / 3³/₄"x24"



stonehenge grafite 30x60cm / 12"x24"



stonehenge savanna 30x60cm / 12"x24" - stonehenge savanna 60x60cm / 24"x24"
stonehenge listone 97 savanna lapp. 9,7x60cm / 3³/₄"x24"

Stonehenge formati e colori

sizes and colors / formats et couleurs / formaten und farben / formatos y colores

savanna



listone 57
5,7x60cm / 2¹/₄"x24"
lapp. rett. **LG9ST86 1740**



listone 97
9,7x60cm / 3³/₄"x24"
lapp. rett. **LG9ST90 1640**



30x60cm / 12"x24"
nat. rett. **LGVSTN0 1280**
lapp. rett. **LGVSTLO 1410**



60x60cm / 24"x24"
nat. rett. **LGWSTN0 1040**
lapp. rett. **LGWSTRO 1280**
lapp. rett. **LGWSTLO 1410**

cardoso



listone 57
5,7x60cm / 2¹/₄"x24"
lapp. rett. **LG9ST87 1740**



listone 97
9,7x60cm / 3³/₄"x24"
lapp. rett. **LG9ST91 1640**



30x60cm / 12"x24"
nat. rett. **LGVSTN2 1280**
lapp. rett. **LGVSTL2 1410**



60x60cm / 24"x24"
nat. rett. **LGWSTN2 1040**
lapp. rett. **LGWSTR2 1280**
lapp. rett. **LGWSTL2 1410**

antracite



listone 57
5,7x60cm / 2¹/₄"x24"
lapp. rett. **LG9ST96 1740**



listone 97
9,7x60cm / 3³/₄"x24"
lapp. rett. **LG9ST97 1640**



30x60cm / 12"x24"
nat. rett. **LGVSTN5 1280**
lapp. rett. **LGVSTL4 1410**



60x60cm / 24"x24"
nat. rett. **LGWSTN4 1040**
lapp. rett. **LGWSTR4 1280**
lapp. rett. **LGWSTL4 1410**

grafite



listone 57
5,7x60cm / 2¹/₄"x24"
lapp. rett. **LG9ST88 1740**



listone 97
9,7x60cm / 3³/₄"x24"
lapp. rett. **LG9ST92 1640**



30x60cm / 12"x24"
nat. rett. **LGVSTN1 1280**
lapp. rett. **LGVSTL1 1410**



60x60cm / 24"x24"
nat. **LGWSTN1 1040**
nat. rett. **LGWSTRI 1280**
lapp. rett. **LGWSTL1 1410**



75x75cm / 30"x30"
nat. rett. **LGOSTRI 1510**

Stonehenge corredi e pezzi speciali

trims and decors / articles et pièces spéciales

formstücke und dekore / decorados y piezas especiales



MOSAICO
cardoso lapp. rett.
30x30cm / 12"x12"
LG9ST47 **2020**



COMP. LISTELLO
cardoso lapp. rett.
30x30cm / 12"x12"
LG9ST23 **0350**

▲
BEAK JOLLY
cardoso
1,3x1,3cm / 1/2"x1/2"
LG9ST43 **0260**

RACCORDO JOLLY
cardoso
1,3x30cm / 1/2"x12"
LG9ST40 **0180**



MOSAICO
antracite lapp. rett.
30x30cm / 12"x12"
LG9ST93 **2020**



COMP. LISTELLO
antracite lapp. rett.
30x30cm / 12"x12"
LG9ST95 **0350**

▲
BEAK JOLLY
antracite
1,3x1,3cm / 1/2"x1/2"
LG9ST07 **0260**

RACCORDO JOLLY
antracite
1,3x30cm / 1/2"x12"
LG9ST59 **0180**

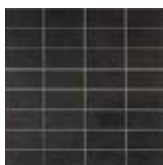

MOSAICO
grafite lapp. rett.
30x30cm / 12"x12"
LG9ST45 **2020**

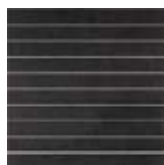

COMP. LISTELLO
grafite lapp. rett.
30x30cm / 12"x12"
LG9ST24 **0350**

▲
BEAK JOLLY
grafite
1,3x1,3cm / 1/2"x1/2"
LG9ST44 **0260**

RACCORDO JOLLY
grafite
1,3x30cm / 1/2"x12"
LG9ST41 **0180**

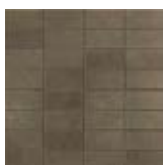

MOSAICO
savanna lapp. rett.
30x30cm / 12"x12"
LG9ST46 **2020**



COMP. LISTELLO
savanna lapp. rett.
30x30cm / 12"x12"
LG9ST22 **0350**

▲
BEAK JOLLY
savanna
1,3x1,3cm / 1/2"x1/2"
LG9ST42 **0260**

RACCORDO JOLLY
savanna
1,3x30cm / 1/2"x12"
LG9ST39 **0180**

LISTELLO METALLO
metallo 30
1,5x30cm / 5/8"x12"
LG9ST03 **0120**

▲
BEAK JOLLY
metallo
1,3x1,3cm / 1/2"x1/2"
LG9ST06 **0160**

LISTELLO METALLO
metallo 60
1,5x60cm / 5/8"x24" **LG9ST02 0350**

RACCORDO JOLLY
metallo 30
1,3x30cm / 1/2"x12"
LG9ST05 **0130**

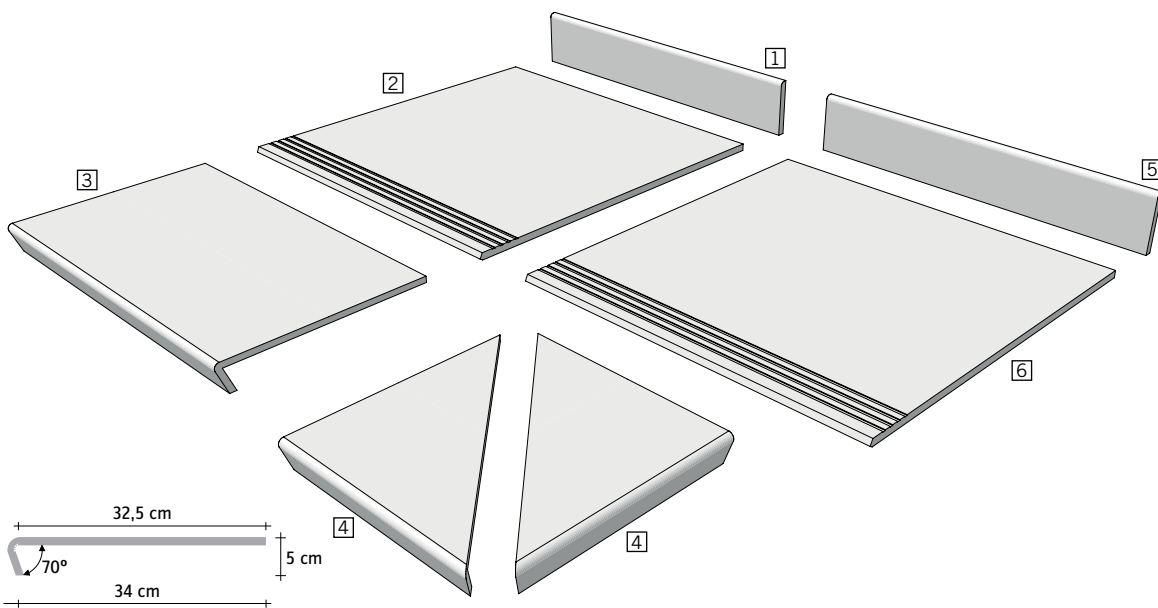

1 BATTISCOPA nat. rett.
10x60cm / 4"x24"

savanna LGBSTS3 0170
cardoso LGBSTS2 0170
antracite LGBSTS4 0170
grafite LGBSTS1 0170

2 GRADINO nat. rett.
60x60cm / 24"x24"

savanna LGCSTG3 0620
cardoso LGCSTG2 0620
antracite LGCSTG4 0620
grafite LGCSTG1 0620

3 GRADINO CONTINUO 60 nat. rett.
5x32,5x60cm / 2"x12^{3/4}"x24"

savanna LG9STN3 1660
cardoso LG9STN2 1660
antracite LG9STN4 1660
grafite LG9STN1 1660

4 GRADINO CONTINUO
ANGOLO SX / DX nat. rett.
5x32,5x32,5cm / 2"x12^{3/4}"x12^{3/4}"

savanna LG9STE2 1760
cardoso LG9STF1 1760
antracite LG9STE8 1760
grafite LG9STE5 1760

5 BATTISCOPA lapp. rett.
10x60cm / 4"x24"

savanna LGBSTV3 0290
cardoso LGBSTV2 0290
antracite LGBSTV4 0290
grafite LGBSTV1 0290

6 GRADINO lapp. rett.
60x60cm / 24"x24"

savanna LGCSTH3 0660
cardoso LGCSTH2 0660
antracite LGCSTH4 0660
grafite LGCSTH1 0660

Tutti i gradini continui sono da posare esclusivamente in interno.
All steps are intended as "indoor use" only.
Tous les nez de marche sont à utiliser exclusivement à l'intérieur.
Alle Stufenplatten sind ausschließlich für die Verlegung im Innenbereich geeignet.
Todos los peldaños/huella son para colocación exclusivamente en interior.

CITY

design Diego Grandi



Moscova Antracite 3D



Cordusio Bronze 3D



30x60cm/12"x24"

***DECORO REALIZZATO CON:**

Decor made with:
Décor réalisé avec:
Das Dekor ist aus hergestellt:
Decoración realizada con:

Imballi pag. 428

Packing
Emballage
Verpackung
Embalajes

GRES SMALTATO A MASSA COLORATA GL

Colored-body glazed porcelain
Grès émaillé à masse colorée
Glasiertes Feisteinzeug mit farbiger masse
Gres esmaltado de masa colorada GL

SPESSORE

Thickness
Epaisseur
Stärke
Espesor

11 mm

FUGA MINIMA CONSIGLIATA

Minimum grout joint recommended
Joint minimum conseillé
Empfohlene Minimalfugenbreit
Distancia recomendada entre las baldosas

1 mm



City formati e colori

sizes and colors / formats et couleurs / formaten und farben / formatos y colores

moscova antracite 3D



30x60cm / 12"x24"

LG9CY00 2010

cordusio bronze 3D



30x60cm / 12"x24"

LG9CY01 2010



MARMI, PORFIDI E SLATE

182	ORIGINI
192	DREAMING
202	STORM
210	OUTDOOR
216	TECNOQUARTZ
226	RAIN FOREST
234	ANCIENT JERUSALEM

 White

 Beige

 Light Grey



30x60cm/12"x24"



60x60cm/24"x24"

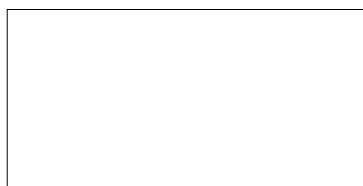

30x120cm/12"x48"

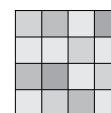

60x120cm/24"x48"

Imballi pag. 431
 Packing
 Emballage
 Verpackung
 Embalajes
GRES TUTTA MASSA UGL
 Full-body porcelain
 Grès Cérame pleine masse
 Vollgemischtes Durchgefärbtes Feinsteinzeug
 Gres toda masa UGL
SPESSORE
 Thickness
 Epaisseur
 Stärke
 Espesor
 10 mm
STONALIZZAZIONE
 Shading
 Denuançage
 Spielfarbig
 Grado de tonalización
**V3****FUGA MINIMA CONSIGLIATA PER POSA IN INTERNO**
 Minimum suggested joint for indoor fixing
 Joint minimum conseillé pour pose en enterieure
 Empfohlene Fugenbreite fuer Innenbereich
 Junta mínima aconsejada para colocación en interior
 2 mm
**RESISTENZA ALLO SCIVOLAMENTO
DIN 51130**
 Slip resistance
 Résistance au glissement
 Rutschfestigkeit
 Resistencia antideslizante

 R9 (nat.)
 R11 (grip)
**RESISTENZA ALLO SCIVOLAMENTO
DIN 51097**
 Slip resistance
 Résistance au glissement
 Rutschfestigkeit
 Resistencia antideslizante
 classe C (grip)
**COEFFICIENTE DI ATTRITO DINAMICO
B.C.R. TORTUS** $\mu > 0,40$ **COEFFICIENT OF FRICTION
ASTM C1028**
 dry - COF ≥ 0.60
 wet - COF ≥ 0.60
**DYNAMIC COEFFICIENT OF FRICTION
BOT 3000**DCOF ≥ 0.42 **BRITISH PENDULUM TEST
BS 7976:2002**
 4S (slider 96)
 dry: low slip potential PTV 36+ (nat./grip)
 wet: low slip potential PTV 36+ (nat./grip)
 TRL (slider 55)
 dry: low slip potential PTV 36+ (grip)
 wet: low slip potential PTV 36+ (grip)
Info Microban pag. 396

ANTIBACTERIAL



origini light grey 60x120cm / 24"x48" nat. rett. - RE-evolution SRC030 100x100cm / 39"x39"



origini beige 30x120cm / 12"x48" nat. rett. - type-32 20x200cm / 8"x79"
metropolis rio coffee 60x60cm / 24"x24"



origini white 30x60cm / 12"x24" nat.



origini light grey 30x120cm / 12"x48" lux rett.



origini light grey 60x120cm / 24"x48" nat. rett. - RE-evolution SRC030 100x100cm / 39"x39"



origini beige 30x120cm / 12"x48" lux rett.



origini light grey 60x60cm / 24"x24" grip rett.

Origini formati e colori

sizes and colors / formats et couleurs / formaten und farben / formatos y colores

white



30x60cm / 12"x24"
lux rett.
nat. rett.

LGVORL5 1375
LGVORV5 1270

beige



30x60cm / 12"x24"
lux rett.
nat. rett.

LGVORL6 1375
LGVORV6 1270



60x60cm / 24"x24"
lux rett.
nat. rett.
*grip rett.

LGWORR5 1520
LGWORX5 1425
LGWOR05 1280



60x60cm / 24"x24"
lux rett.
nat. rett.
*grip rett.

LGWORR6 1520
LGWORX6 1425
LGWOR15 1280

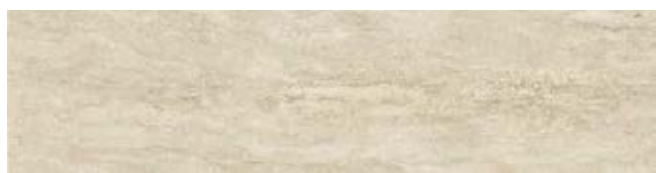

30x120cm / 12"x48"
lux rett.
nat. rett.

LG6OR55 1585
LG6OR80 1520



30x120cm / 12"x48"
lux rett.
nat. rett.

LG6OR65 1585
LG6OR85 1520



60x120cm / 24"x48"
lux rett.
nat. rett.

LGXORR5 1585
LGXORX5 1520



60x120cm / 24"x48"
lux rett.
nat. rett.

LGXORR6 1585
LGXORX6 1520

light grey



30x60cm / 12"x24"
lux rett.
nat. rett.

LGVORL7 1375
LGVORV7 1270



60x60cm / 24"x24"
lux rett.
nat. rett.
*grip rett.

LGWORR7 1520
LGWORX7 1425
LGWOR25 1280



30x120cm / 12"x48"
lux rett.
nat. rett.

LG6OR75 1585
LG6OR95 1520



60x120cm / 24"x48"
lux rett.
nat. rett.

LGXORR7 1585
LGXORX7 1520

*non trattato con antibatterico
without antimicrobial treatment
sans traitement antibacterien
nicht mit antibakterieller
Wirkung ausgestattet

Origini corredi

decors / decors / dekore / decoros



CHAIN lux
30x60cm / 12"x24"
white

LGVORH0 0880



BARRÈ
30x60cm / 12"x24"
white

LG9OR60 1035



TWIST nat.
30x120cm / 12"x48"
white

LG6ORT0 1615



CHAIN lux
30x60cm / 12"x24"
beige

LGVORH1 0880



BARRÈ
30x60cm / 12"x24"
beige

LG9OR61 1035



TWIST nat.
30x120cm / 12"x48"
beige

LG6ORT1 1615



CHAIN lux
30x60cm / 12"x24"
light grey

LGVORH2 0880



BARRÈ
30x60cm / 12"x24"
light grey

LG9OR62 1035



TWIST nat.
30x120cm / 12"x48"
light grey

LG6ORT2 1615



GRAN DAMIER
30x30cm / 12"x12"
white lux
LG9OR70 0715



TWEED
30x30cm / 12"x12"
white nat.
LG9OR50 0715

BACCHETTA METAL*
1,5x60cm / 5/8"x24"
titanio LG9ML0T 0395



GRAN DAMIER
30x30cm / 12"x12"
beige lux
LG9OR71 0715

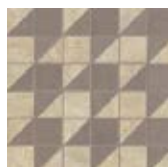

TWEED
30x30cm / 12"x12"
beige nat.
LG9OR51 0715

BACCHETTA METAL*
1,5x60cm / 5/8"x24"
nero LG9ML0N 0395



GRAN DAMIER
30x30cm / 12"x12"
light grey lux
LG9OR72 0715



TWEED
30x30cm / 12"x12"
light grey nat.
LG9OR52 0715

BACCHETTA METAL*
1,5x60cm / 5/8"x24"
moka LG9ML0G 0395

*non trattato con antibatterico
without antimicrobial treatment
sans traitement antibactérien
nicht mit antibakterieller
Wirkung ausgestattet

Origini pezzi speciali

trims / pièces spéciales / formstücke / piezas especiales

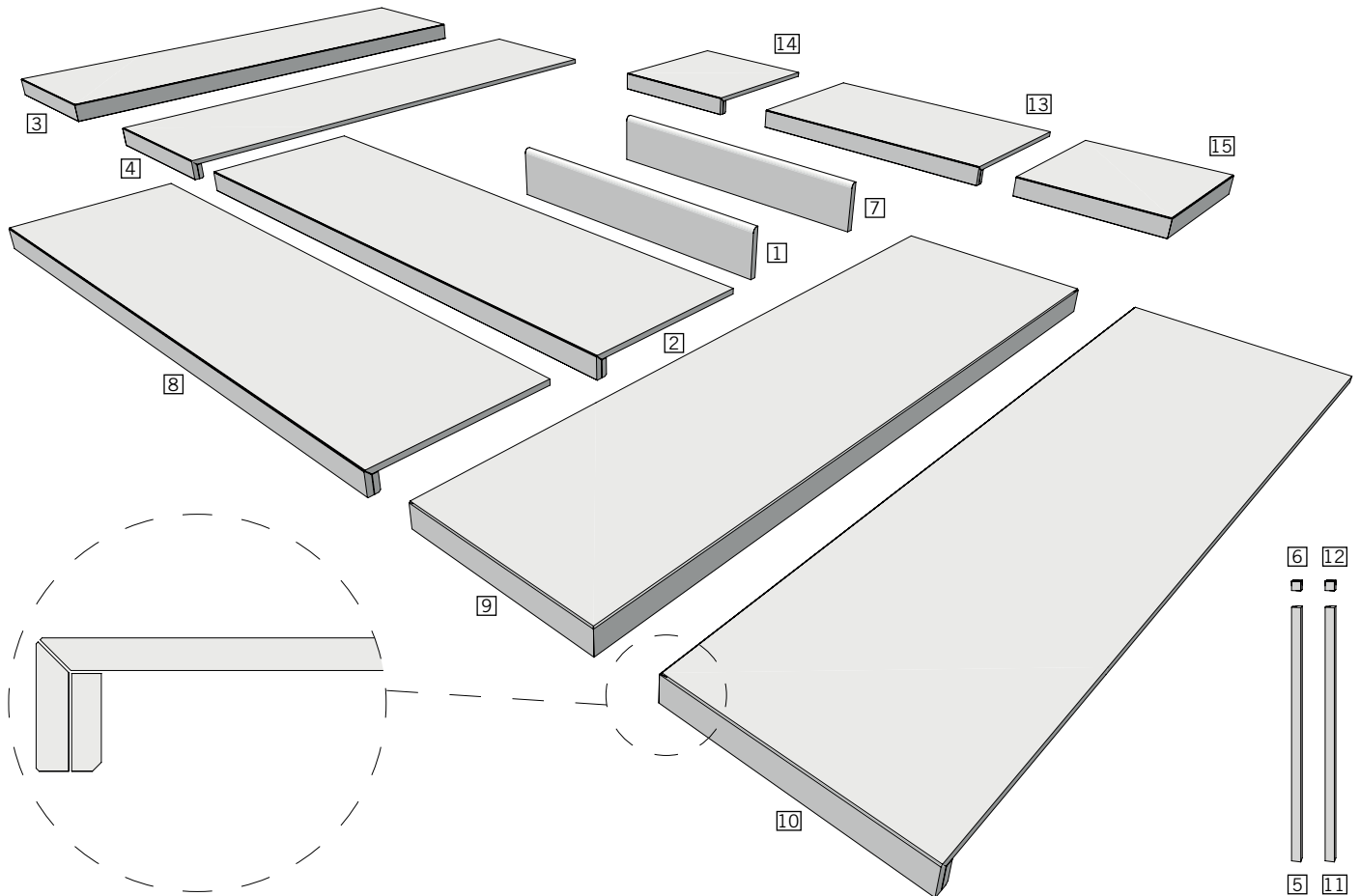

lux

- | | | | |
|---|--|--|--|
| <p>1 BATTISCOPIA lux
10x60cm / 4"x24"
white
beige
light grey</p> <p>LGBOR00 0250
LGBOR10 0250
LGBOR20 0250</p> | <p>2 GRADINO PLUS lux
35x120cm / 13^{3/4}"x48"
white
beige
light grey</p> <p>LG9ORG5 1985
LG9ORG6 1985
LG9ORG7 1985</p> | <p>3 ANGOLO SX GRADINO PLUS lux
35x120cm / 13^{3/4}"x48"
white
beige
light grey</p> <p>LG9ORS5 2125
LG9ORS6 2125
LG9ORS7 2125</p> | <p>4 ANGOLO DX GRADINO PLUS lux
35x120cm / 13^{3/4}"x48"
white
beige
light grey</p> <p>LG9ORD5 2125
LG9ORD6 2125
LG9ORD7 2125</p> |
| <p>5 RACCORDO JOLLY lux
1,3x30cm / 1/2"x12"
white
beige
light grey</p> <p>LG9ORJ0 0180
LG9ORJ1 0180
LG9ORJ2 0180</p> | <p>6 BEAK JOLLY lux
1,3x2cm / 1/2"x3/4"
white
beige
light grey</p> <p>LG9ORK0 0260
LG9ORK1 0260
LG9ORK2 0260</p> | | |

nat.

- | | | | |
|---|---|---|--|
| <p>7 BATTISCOPIA nat.
10x60cm / 4"x24"
white
beige
light grey</p> <p>LGBOR05 0200
LGBOR15 0200
LGBOR25 0200</p> | <p>8 GRADINO PLUS nat.
35x120cm / 13^{3/4}"x48"
white
beige
light grey</p> <p>LG9ORNO 1985
LG9ORNI 1985
LG9ORN2 1985</p> | <p>9 ANGOLO SX GRADINO PLUS nat.
35x120cm / 13^{3/4}"x48"
white
beige
light grey</p> <p>LG9ORE0 2125
LG9ORE1 2125
LG9ORE2 2125</p> | <p>10 ANGOLO DX GRADINO PLUS nat.
35x120cm / 13^{3/4}"x48"
white
beige
light grey</p> <p>LG9ORA0 2125
LG9ORA1 2125
LG9ORA2 2125</p> |
| <p>11 RACCORDO JOLLY nat.
1,3x30cm / 1/2"x12"
white
beige
light grey</p> <p>LG9ORJ5 0180
LG9ORJ6 0180
LG9ORJ7 0180</p> | <p>12 BEAK JOLLY nat.
1,3x2cm / 1/2"x3/4"
white
beige
light grey</p> <p>LG9ORK5 0260
LG9ORK6 0260
LG9ORK7 0260</p> | | |

grip*

- | | | |
|--|--|--|
| <p>13 GRADINO PLUS grip*
35x60cm / 13^{3/4}"x24"
white
beige
light grey</p> <p>LG9ORG0 1630
LG9ORG1 1630
LG9ORG2 1630</p> | <p>14 ANGOLO SX GRADINO PLUS grip*
35x35cm / 13^{3/4}"x13^{3/4}"
white
beige
light grey</p> <p>LG9ORS0 1970
LG9ORS1 1970
LG9ORS2 1970</p> | <p>15 ANGOLO DX GRADINO PLUS grip*
35x35cm / 13^{3/4}"x13^{3/4}"
white
beige
light grey</p> <p>LG9ORD0 1970
LG9ORD1 1970
LG9ORD2 1970</p> |
|--|--|--|

DREAMING

 Bianco Statuario

 Crystal White

 Romance Safari

 Passion Pulpis



30x60cm/12"x24"

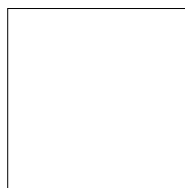

60x60cm/24"x24"



75x75cm/30"x30"

Imballi pag. 428

Packing
Emballage
Verpackung
Embalajes

GRES SMALTATO A MASSA COLORATA GL

Colored-body glazed porcelain
Grès émaillé à masse colorée
Glasiertes Feisteinzeug mit farbiger Masse
Gres esmaltado de masa colorada GL

SPESSORE

Thickness
Epaisseur
Stärke
Espesor
10 mm (30x60 - 60x60)
11 mm (75x75)

STONALIZZAZIONE

Shading
Denuançage
Spielfarbig
Grado de tonalización

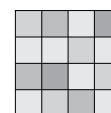

V3

FUGA MINIMA CONSIGLIATA

Minimum grout joint recommended
Joint minimum conseillé
Empfohlene Minimalfugenbreite
Distancia recomendada entre las baldosas

2 mm

RESISTENZA ALL'ABRASIONE SUPERFICIALE ISO 10545-7

Resistance to superficial abrasion
Résistance à l'abrasion superficielle
Oberflächliche reibungsbeständigkeit
Resistencia a la abrasión superficial

pei 4 lux
pei 5 velvet

COEFFICIENT OF FRICTION ASTM C1028

dry - COF \geq 0.60 (velvet)
wet - COF \geq 0.60 (velvet)

DYNAMIC COEFFICIENT OF FRICTION BOT 3000

DCOF \geq 0.42 (velvet)



Il prodotto è stato
realizzato in
Italia da
Cassa di
Cassa di
Cassa di



dreaming passion pulpis 75x75cm / 30"x30" lux rett.



dreaming bianco statuario 75x75cm / 30"x30" lux rett.



dreaming crystal white 60x60cm / 24"x24" lux rett.

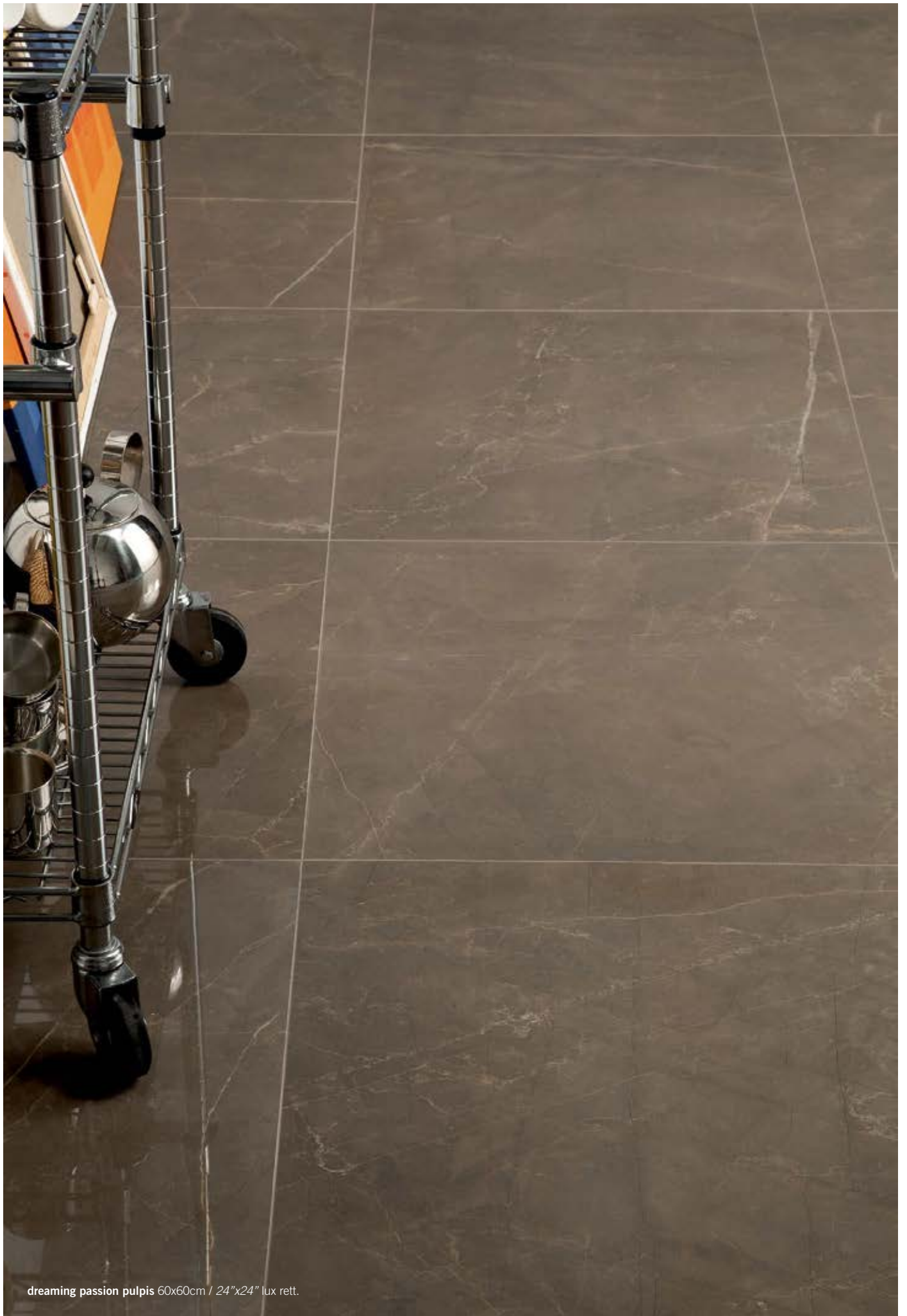

dreaming passion pulpis 60x60cm / 24"x24" lux rett.



dreaming crystal white 60x60cm / 24"x24" lux rett.



dreaming romance safari 75x75cm / 30"x30" velvet rett.

Dreaming formati e colori

sizes and colors / formats et couleurs / formaten und farben / formatos y colores

bianco statuario



75x75cm / 30"x30"
lux rett.
velvet rett.

LGOETL4 1580
LGOETR4 1520

crystal white



75x75cm / 30"x30"
lux rett.
velvet rett.

LGOETL0 1580
LGOETRO 1520

romance safari



75x75cm / 30"x30"
lux rett.
velvet rett.

LGOETL1 1580
LGOETR1 1520



60x60cm / 24"x24"
lux rett.
velvet rett.

LGWETL4 1675
LGWETR4 1370



60x60cm / 24"x24"
lux rett.
velvet rett.

LGWETV0 1675
LGWETRO 1370



60x60cm / 24"x24"
lux rett.
velvet rett.

LGWETV1 1675
LGWETR1 1370



30x60cm / 12"x24"
lux rett.
velvet rett.

LGVETL4 1675
LGVETR4 1370

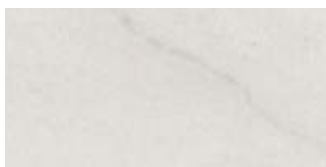

30x60cm / 12"x24"
lux rett.
velvet rett.

LGVETX0 1675
LGVETRO 1370

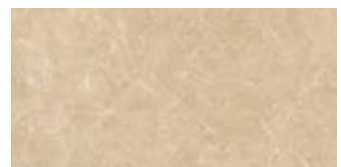

30x60cm / 12"x24"
lux rett.
velvet rett.

LGVETX1 1675
LGVETR1 1370

Dreaming corredi

decors / articles / dekore / decorados

passion pulpis



75x75cm / 30"x30"
lux rett.
velvet rett.

LGOETL2 1580
LGOETR2 1520



MOSAICO BASIC
30x30cm / 12"x12"
bianco statuario lux
LG9ETM4 2070

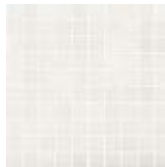

MOSAICO BASIC
30x30cm / 12"x12"
crystal white lux
LG9ETM0 2070



60x60cm / 24"x24"
lux rett.
velvet rett.

LGWETV2 1675
LGVETR2 1370

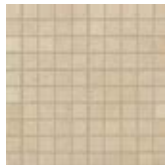

MOSAICO BASIC
30x30cm / 12"x12"
romance safari lux
LG9ETM1 2070



30x60cm / 12"x24"
lux rett.
velvet rett.

LGVETX2 1675
LGVETR2 1370

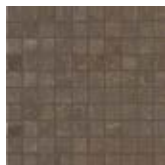

MOSAICO BASIC
30x30cm / 12"x12"
passion pulpis lux
LG9ETM2 2070

Dreaming pezzi speciali

trims / pièces spéciales / formstücke / piezas especiales

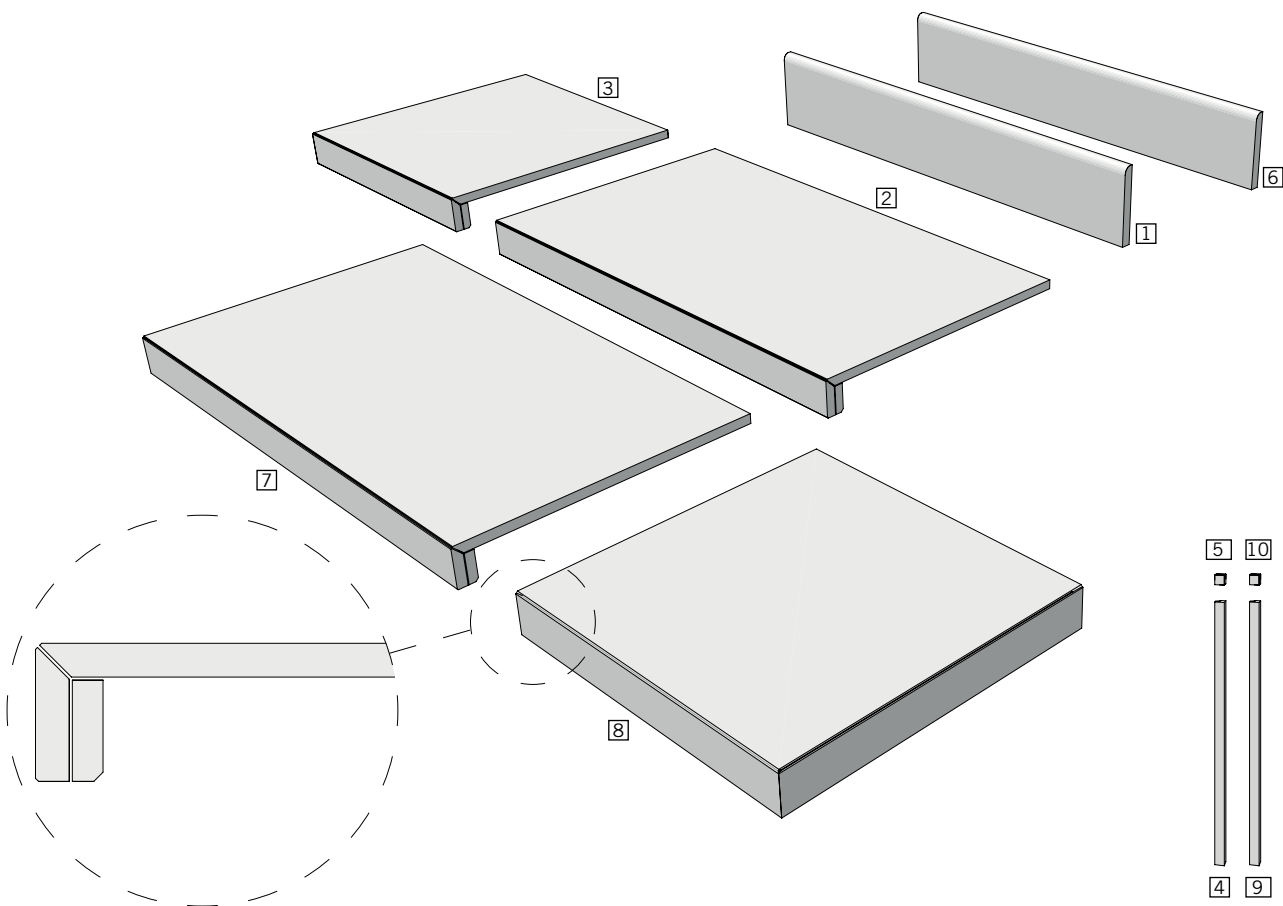

lux

- | | | | | | |
|---|--|---|--|--|--|
| <p>1 BATTISCOPIA lux
10x60cm / 4"x24"
bianco statuario
crystal white
romance safari
passion pulpis</p> | <p>LGBETX4 0230
LGBETX0 0230
LGBETX1 0230
LGBETX2 0230</p> | <p>2 GRADINO PLUS lux
35x60cm / 13^{3/4}"x24"
bianco statuario
crystal white
romance safari
passion pulpis</p> | <p>LG9ETG4 1760
LG9ETG0 1760
LG9ETG1 1760
LG9ETG2 1760</p> | <p>3 ANGOLO SX / DX GRADINO PLUS lux
35x35cm / 13^{3/4}"x13^{3/4}"
bianco statuario
crystal white
romance safari
passion pulpis</p> | <p>LG9ETD4 1990
LG9ETD0 1990
LG9ETD1 1990
LG9ETD2 1990</p> |
| <p>4 RACCORDO JOLLY lux
1,3x30cm / 1/2"x12"
bianco statuario
crystal white
romance safari
passion pulpis</p> | <p>LG9ETJ4 0180
LG9ETJ0 0180
LG9ETJ1 0180
LG9ETJ2 0180</p> | <p>5 BEAK JOLLY lux
1,3x2cm / 1/2"x3/4"
bianco statuario
crystal white
romance safari
passion pulpis</p> | <p>LG9ETK4 0260
LG9ETK0 0260
LG9ETK1 0260
LG9ETK2 0260</p> | | |

velvet

- | | | | | | |
|--|--|--|--|---|--|
| <p>6 BATTISCOPIA velvet
10x60cm / 4"x24"
bianco statuario
crystal white
romance safari
passion pulpis</p> | <p>LGBETR4 0150
LGBETR0 0150
LGBETR1 0150
LGBETR2 0150</p> | <p>7 GRADINO PLUS velvet
35x60cm / 13^{3/4}"x24"
bianco statuario
crystal white
romance safari
passion pulpis</p> | <p>LG9ETG9 1630
LG9ETG5 1630
LG9ETG6 1630
LG9ETG7 1630</p> | <p>8 ANGOLO SX / DX GRADINO PLUS velvet
35x35cm / 13^{3/4}"x13^{3/4}"
bianco statuario
crystal white
romance safari
passion pulpis</p> | <p>LG9ETD9 1970
LG9ETD5 1970
LG9ETD6 1970
LG9ETD7 1970</p> |
| <p>9 RACCORDO JOLLY velvet
1,3x30cm / 1/2"x12"
bianco statuario
crystal white
romance safari
passion pulpis</p> | <p>LG9ETJ9 0180
LG9ETJ5 0180
LG9ETJ6 0180
LG9ETJ3 0180</p> | <p>10 BEAK JOLLY velvet
1,3x2cm / 1/2"x3/4"
bianco statuario
crystal white
romance safari
passion pulpis</p> | <p>LG9ETK9 0260
LG9ETK5 0260
LG9ETK6 0260
LG9ETK7 0260</p> | | |



dreaming bianco statuario 75x75cm / 30"x30" lux

STORM

 Icestorm

 Tropicalstorm

 Darkstorm



30x30cm/12"x12"

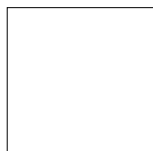

45x45cm/18"x18"



30x60cm/12"x24"
30x60,4cm/12"x24"

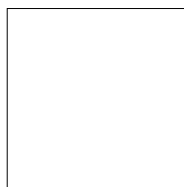

60x60cm/24"x24"

Imballi pag. 434

Packing
Emballage
Verpackung
Embalajes

GRES SMALTATO A MASSA COLORATA GL

Colored-body glazed porcelain
Grès émaillé à masse colorée
Glasiertes Feinsteinzeug mit farbiger Masse
Gres esmaltado de masa colorada GL

FUGA MINIMA CONSIGLIATA

Minimum grout joint recommended
Joint minimum conseillé
Empfohlene Minimalfugenbreite
Distancia recomendada entre las baldosas

2 mm rettificato
4 mm naturale

RESISTENZA ALLO SCIVOLAMENTO DIN 51130

Slip resistance
Résistance au glissement
Rutschfestigkeit
Resistencia antideslizante

R9

RESISTENZA ALL'ABRASIONE SUPERFICIALE ISO 10545-7

Resistance to superficial abrasion
Résistance à l'abrasion superficielle
Oberflächliche reibungsbeständigkeit
Resistencia a la abrasión superficial

pei 5 (tropicalstorm/icestorm)
pei 4 (darkstorm)

SPESSORE

Thickness
Épaisseur
Stärke
Espesor

9 mm (30x30 nat. - 30x60,4 nat. - 45x45)
11 mm (30x30 rett. - 30x60 rett. - 60x60)

COEFFICIENTE DI ATTRITO DINAMICO B.C.R. TORTUS

$\mu > 0,40$

COEFFICIENT OF FRICTION ASTM C1028

dry - COF ≥ 0.60
wet - COF ≥ 0.60

STONALIZZAZIONE

Shading
Denuançage
Spielfarbig
Grado de tonalización

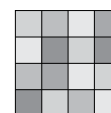

V4



storm icestorm muretto 30x60cm / 12"x24"



storm tropicalstorm 60x60cm / 24"x24"



storm icestorm 30x60cm / 12"x24" - storm icestorm 60x60cm / 24"x24"
storm icestorm muretto 30x60cm / 12"x24" - storm icestorm mosaico 3 30x30cm / 12"x12"

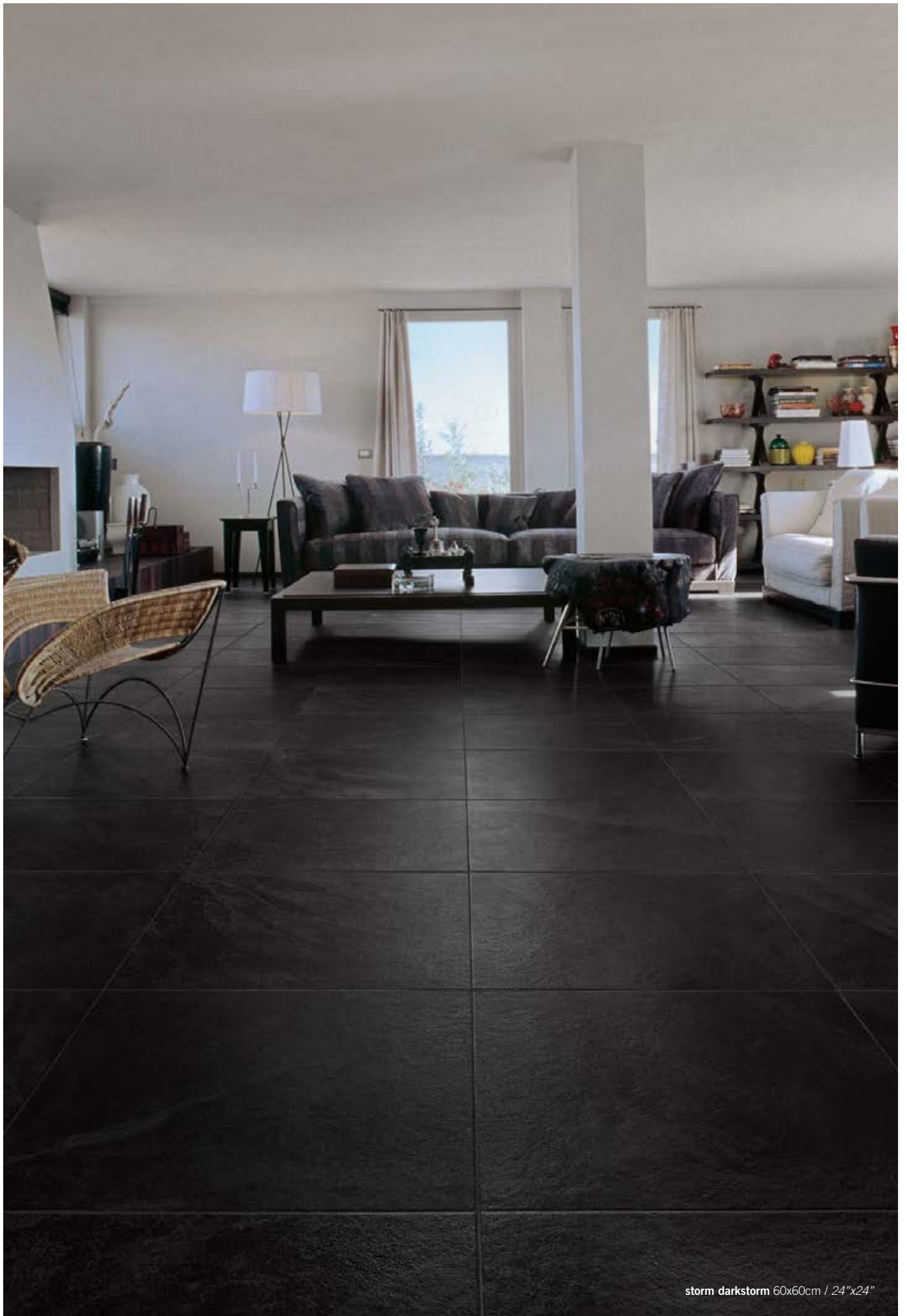

storm darkstorm 60x60cm / 24"x24"

Storm formati e colori

sizes and colors / formats et couleurs / formaten und farben / formatos y colores

icestorm



30x30cm / 12"x12"
nat. rett. (spessore 11mm) LGPS2R4 1470
nat. (spessore 9mm) LGPS240 0970

tropicalstorm



30x30cm / 12"x12"
nat. rett. (spessore 11mm) LGPS2R3 1470
nat. (spessore 9mm) LGPS230 0970

darkstorm

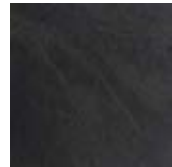

30x30cm / 12"x12"
nat. rett. (spessore 11mm) LGPS2R5 1470
nat. (spessore 9mm) LGPS250 0970



45x45cm / 18"x18"
nat. (spessore 9mm) LGTS2N4 1080



45x45cm / 18"x18"
nat. (spessore 9mm) LGTS2N3 1080

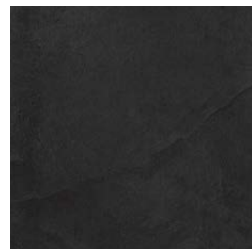

45x45cm / 18"x18"
nat. (spessore 9mm) LGTS2N5 1080



30x60cm / 12"x24"
nat. rett. (spessore 11mm) LGVS2R4 1470
30x60,4cm / 12"x24"
nat. (spessore 9mm) LGVS240 0970



30x60cm / 12"x24"
nat. rett. (spessore 11mm) LGVS2R3 1470
30x60,4cm / 12"x24"
nat. (spessore 9mm) LGVS230 0970



30x60cm / 12"x24"
nat. rett. (spessore 11mm) LGVS2R5 1470
30x60,4cm / 12"x24"
nat. (spessore 9mm) LGVS250 0970



60x60cm / 24"x24"
nat. rett. (spessore 11mm) LGWS2R4 1470
nat. (spessore 11mm) LGWS240 1270



60x60cm / 24"x24"
nat. rett. (spessore 11mm) LGWS2R3 1470
nat. (spessore 11mm) LGWS230 1270



60x60cm / 24"x24"
nat. rett. (spessore 11mm) LGWS2R5 1470
nat. (spessore 11mm) LGWS250 1270

Storm corredi

decors / articles / dekore / decorados



LISTONE LINK
icestorm
30x60cm / 12"x24"
LG9S218 1940



LISTONE LINK
tropicalstorm
30x60cm / 12"x24"
LG9S217 1940



LISTONE LINK
darkstorm
30x60cm / 12"x24"
LG9S219 1940



MURETTO
icestorm
30x60cm / 12"x24"
LG9S213 1960



MURETTO
tropicalstorm
30x60cm / 12"x24"
LG9S212 1960



MURETTO
darkstorm
30x60cm / 12"x24"
LG9S214 1960



DECORO MURETTO 3D
icestorm
15x60cm / 6"x24"
LG9S251 0600



DECORO MURETTO 3D
tropicalstorm
15x60cm / 6"x24"
LG9S254 0600



DECORO MURETTO 3D
darkstorm
15x60cm / 6"x24"
LG9S250 0600



MOSAICO 10
icestorm
30x30cm / 12"x12"
LG9S203 1600



MOSAICO 10
tropicalstorm
30x30cm / 12"x12"
LG9S202 1600



MOSAICO 10
darkstorm
30x30cm / 12"x12"
LG9S204 1600



MOSAICO 3
icestorm
30x30cm / 12"x12"
LG9S208 2070



MOSAICO 3
tropicalstorm
30x30cm / 12"x12"
LG9S207 2070



MOSAICO 3
darkstorm
30x30cm / 12"x12"
LG9S209 2070

Storm pezzi speciali

trims / pièces spéciales / besondere stücke / piezas especiales

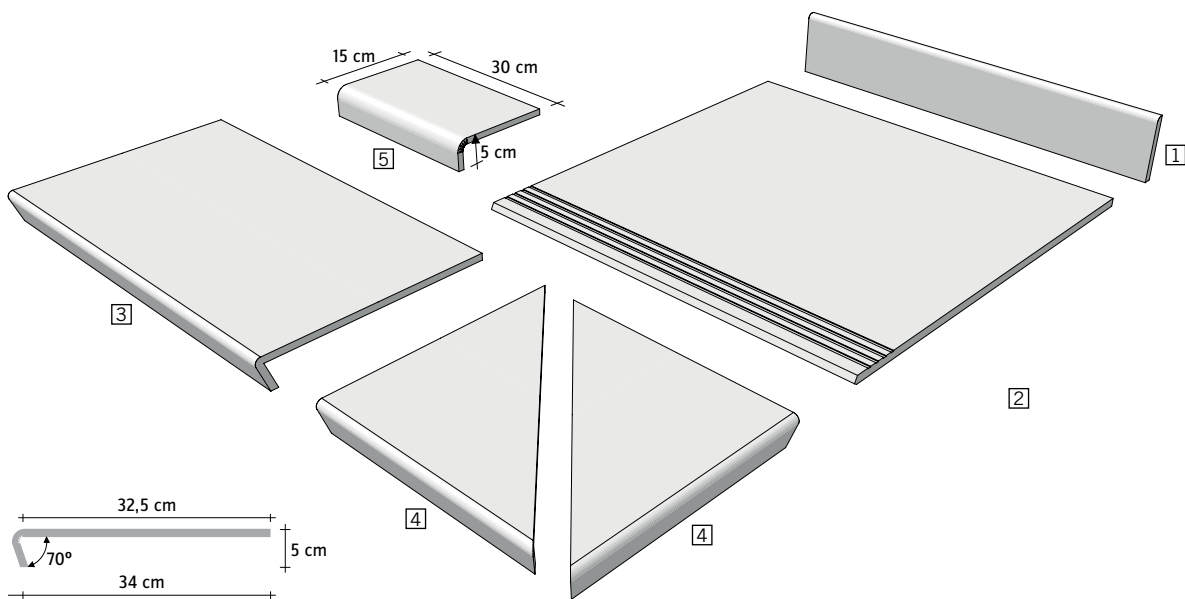

1 BATTISCOPA nat. rett.
10x60cm / 4"x24"
icestorm LGBS240 0200
tropicalstorm LGBS230 0200
darkstorm LGBS250 0200

2 GRADINO STEP nat. rett.
60x60cm / 24"x24"
icestorm LGCS2R4 0610
tropicalstorm LGCS2R3 0610
darkstorm LGCS2R5 0610

3 GRADINO CONTINUO 60 nat. rett.
5x32,5x60cm / 2"x12^{3/4}"x24"
icestorm LG9S226 1610
tropicalstorm LG9S228 1610
darkstorm LG9S225 1610

4 GRADINO CONTINUO
ANGOLO SX / DX nat. rett.
5x32,5x32,5cm / 2"x12^{3/4}"x12^{3/4}"
icestorm LG9S231 1970
tropicalstorm LG9S233 1970
darkstorm LG9S230 1970

5 ELEMENTO A ELLE CONTINUO
nat. rett.
5x15x30cm / 2"x6"x12"
icestorm LG9S223 0510
tropicalstorm LG9S222 0510
darkstorm LG9S224 0510

Tutti i gradini continui sono da posare esclusivamente in interno.
All steps are intended as "indoor use"only.
Tous les nez de marche sont à utiliser exclusivement à l'intérieur.
Alle Stufenplatten sind ausschließlich für die Verlegung im Innenbereich geeignet.
Todos los peldaños/huella son para colocación exclusivamente en interior.





OUTDOOR

 Dorato

 Grigio

 Bruno

20x20cm/8"x8"

20x30,2cm/8"x12"

20x40,4cm/8"x16"

Imballi pag. 431

Packing
Emballage
Verpackung
Embalajes

GRES TUTTA MASSA UGL

Full-body porcelain
Grès Cérame pleine masse
Vollgemischtes Durchgefärbtes Feinsteinzeug
Gres toda masa UGL

SPESSORE

Thickness
Epaisseur
Stärke
Espesor
9 mm

STONALIZZAZIONE

Shading
Denuançage
Spielfarbig
Grado de tonalización

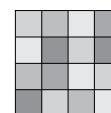

V4

FUGA MINIMA CONSIGLIATA

Minimum grout joint recommended
Joint minimum conseillé
Empfohlene Minimalfugenbreit
Distancia recomendada entre las baldosas
5 mm

RESISTENZA ALLO SCIVOLAMENTO DIN 51130

Slip resistance
Résistance au glissement
Rutschfestigkeit
Resistencia antideslizante
R11

COEFFICIENTE DI ATTRITO DINAMICO B.C.R. TORTUS

$\mu > 0,40$

RESISTENZA ALLO SCIVOLAMENTO DIN 51097

Slip resistance
Résistance au glissement
Rutschfestigkeit
Resistencia antideslizante

COEFFICIENT OF FRICTION ASTM C1028

dry - COF ≥ 0.60
wet - COF ≥ 0.60

classe C



outdoor dorato 20x40,4cm / 8"x16" - outdoor dorato 20x30,2cm / 8"x12" - outdoor dorato 20x20cm / 8"x8"



outdoor grigio 20x40,4cm / 8"x16"



outdoor bruno 20x40,4cm / 8"x16" - **outdoor bruno** 20x30,2cm / 8"x12"
outdoor bruno 20x20cm / 8"x8"

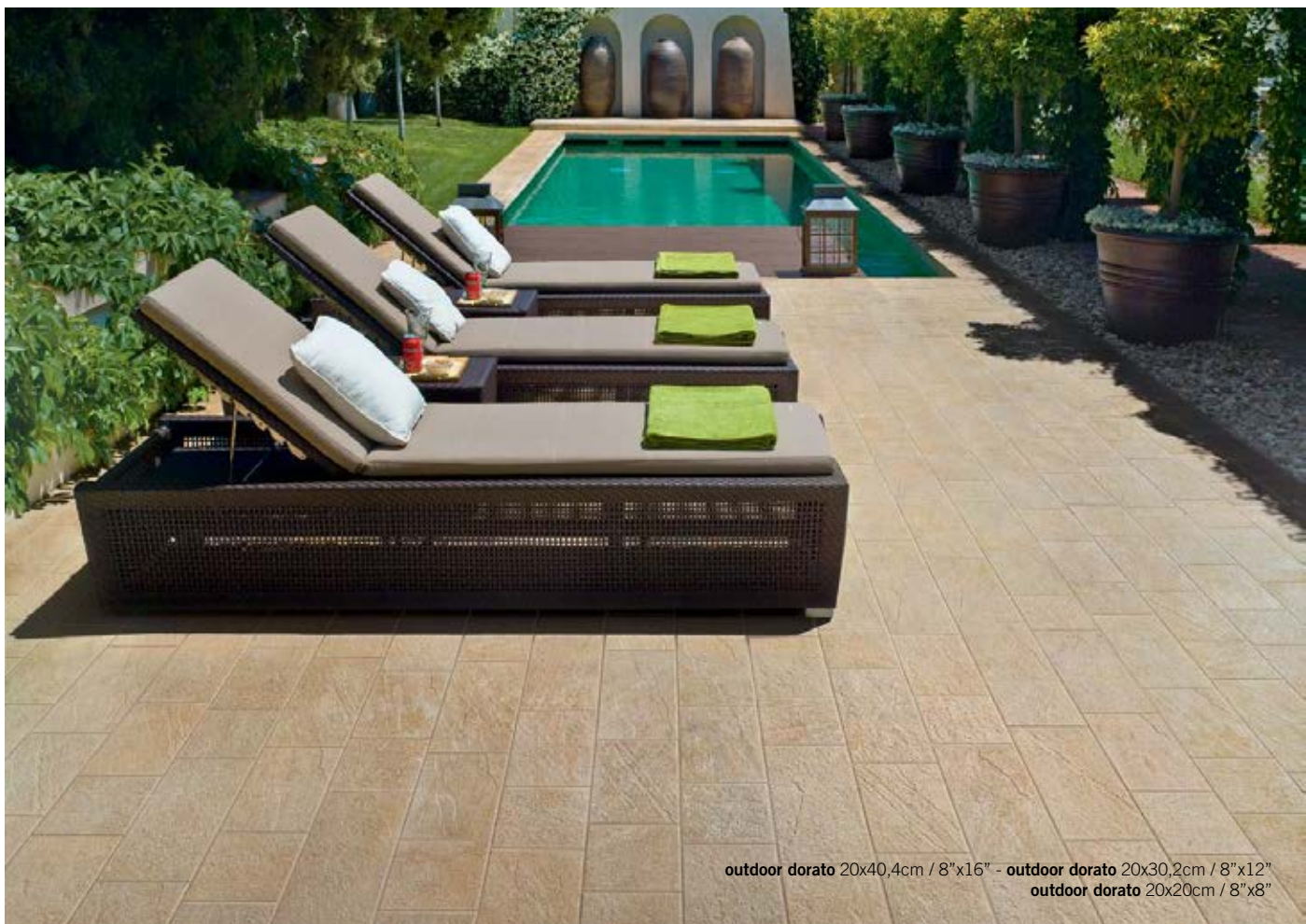

outdoor dorato 20x40,4cm / 8"x16" - **outdoor dorato** 20x30,2cm / 8"x12"
outdoor dorato 20x20cm / 8"x8"

Outdoor formati, colori e pezzi speciali

sizes, colors and trims / formats, couleurs et pièces spéciales

formaten, farben und besondere stücke / formatos, colores y piezas especiales

dorato



20x40,4cm / 8"x16"
nat. LGUOD00 0890

grigio



20x40,4cm / 8"x16"
nat. LGUOD10 0890

bruno



20x40,4cm / 8"x16"
nat. LGUOD20 0890



20x30,2cm / 8"x12"
nat. LGHOD00 0890



20x30,2cm / 8"x12"
nat. LGHOD10 0890



20x30,2cm / 8"x12"
nat. LGHOD20 0890



20x20cm / 8"x8"
nat. LGLOD00 0890



20x20cm / 8"x8"
nat. LGLOD10 0890



20x20cm / 8"x8"
nat. LGLOD20 0890

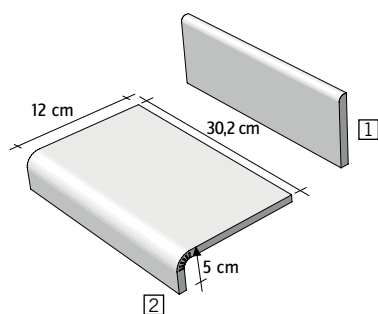

1 BATTISCOPIA nat. rett.
10x30,2cm / 4"x12"

dorato LGBOD00 0070
grigio LGBOD10 0070
bruno LGBOD20 0070

2 ELEMENTO A ELLE CONTINUO nat. rett.
5x12x30,2cm / 2"x4 3/4"x12"

dorato LG9OD00 0460
grigio LG9OD01 0460
bruno LG9OD02 0460



outdoor bruno 20x40,4cm / 8"x16" - outdoor bruno 20x30,2cm / 8"x12"
outdoor bruno 20x20cm / 8"x8"

TECNOQUARTZ

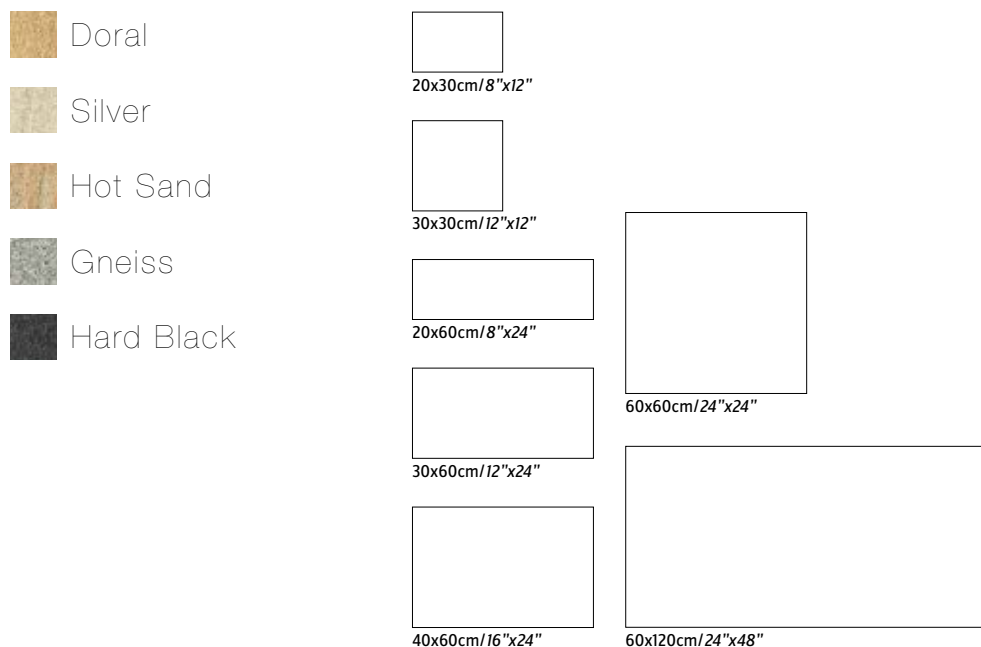

Imballi pag. 435
Packing
Emballage
Verpackung
Embalajes

GRES TUTTA MASSA UGL

Full-body porcelain
Grès Cérame pleine masse
Vollgemischtes Durchgefärbtes Feinsteinzeug
Gres toda masa UGL

SPESSORE

Thickness
Epaisseur
Stärke
Espesor
12 mm

STONALIZZAZIONE

Shading
Denuançage
Spielfarbig
Grado de tonalización

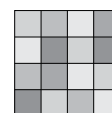

V4

FUGA MINIMA CONSIGLIATA

Minimum grout joint recommended
Joint minimum conseillé
Empfohlene Minimalfugenbreit
Distancia recomendada entre las baldosas
2 mm

RETTIFICATO MONOCALIBRO

Single caliber rectified
Monocalibre réctifié
Monokaliber rectifiziert
Rectificado monocálbro



IT / 021 / 010

RESISTENZA ALLO SCIVOLAMENTO DIN 51130

Slip resistance
Résistance au glissement
Rutschfestigkeit
Resistencia antideslizante

R10 (doral/silver/gneiss)
R11 (hot sand/hard black)

COEFFICIENTE DI ATTRITO DINAMICO B.C.R. TORTUS

$\mu > 0,40$

DOPPIA PRESSATURA

Double pressed
Double passage
Doppelte pressung
Doble prensado

RESISTENZA ALLO SCIVOLAMENTO DIN 51097

Slip resistance
Résistance au glissement
Rutschfestigkeit
Resistencia antideslizante

classe B

COEFFICIENT OF FRICTION ASTM C1028

dry - COF ≥ 0.60
wet - COF ≥ 0.60

DYNAMIC COEFFICIENT OF FRICTION BOT 3000

DCOF ≥ 0.42



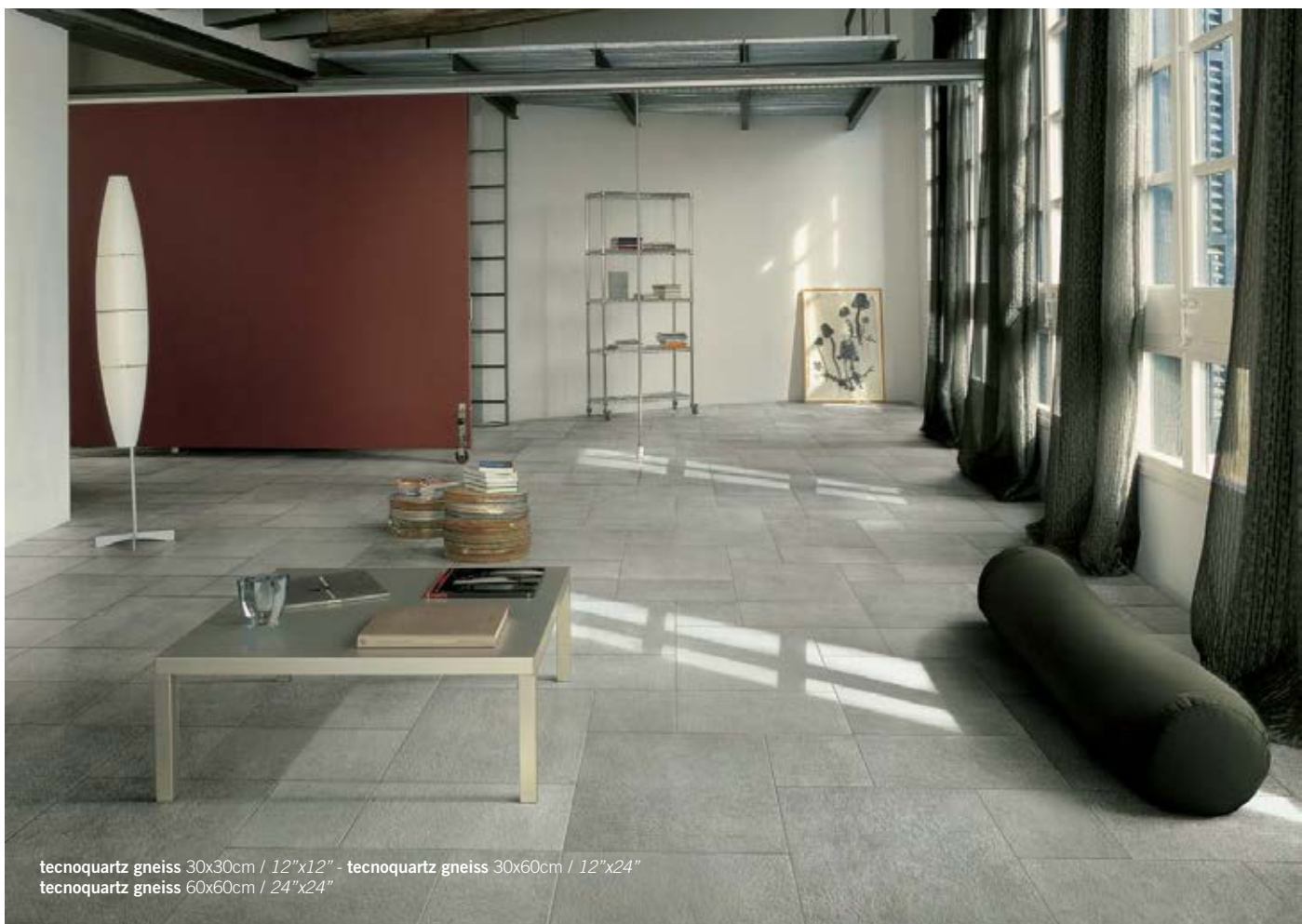

tecnoquartz gneiss 30x30cm / 12"x12" - **tecnoquartz gneiss 30x60cm / 12"x24"**
tecnoquartz gneiss 60x60cm / 24"x24"



tecnoquartz doral 20x30cm / 8"x12" - **tecnoquartz doral 30x30cm / 12"x12"**
tecnoquartz doral 20x60cm / 8"x24" - **tecnoquartz doral 30x60cm / 12"x24"**
tecnoquartz doral 40x60cm / 16"x24" - **tecnoquartz doral 60x60cm / 24"x24"**



Tecnoquartz formati e colori

sizes and colors / formats et couleurs / formaten und farben / formatos y colores

doral



20x30cm / 8"x12"
nat. rett. LGHTQ00 1500



30x30cm / 12"x12"
nat. rett. LGCTQ00 1500



20x60cm / 8"x24"
nat. rett. LGKTQ00 1500



30x60cm / 12"x24"
nat. rett. LGVTQ00 1500



40x60cm / 16"x24"
nat. rett. LGJTQ01 1500



60x60cm / 24"x24"
nat. rett. LGWTQ01 1500



60x120cm / 24"x48"
nat. rett. LGXTQR5 1650

hot sand



20x30cm / 8"x12"
nat. rett. LGHTQ40 1500

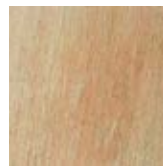

30x30cm / 12"x12"
nat. rett. LGCTQ40 1500



20x60cm / 8"x24"
nat. rett. LGKTQ40 1500



30x60cm / 12"x24"
nat. rett. LGVTQ40 1500



40x60cm / 16"x24"
nat. rett. LGJTQ41 1500



60x60cm / 24"x24"
nat. rett. LGWTQ41 1500



60x120cm / 24"x48"
nat. rett. LGXTQR9 1650

silver



20x30cm / 8"x12"
nat. rett. LGHTQ10 1500



30x30cm / 12"x12"
nat. rett. LGCTQ10 1500



20x60cm / 8"x24"
nat. rett. LGKTQ10 1500



30x60cm / 12"x24"
nat. rett. LGVTQ10 1500



40x60cm / 16"x24"
nat. rett. LGJTQ11 1500



60x60cm / 24"x24"
nat. rett. LGWTQ11 1500



60x120cm / 24"x48"
nat. rett. LGXTQR6 1650

gneiss



20x30cm / 8"x12"
nat. rett. LGHTQ20 1500



30x30cm / 12"x12"
nat. rett. LGCTQ20 1500



20x60cm / 8"x24"
nat. rett. LGKTQ20 1500



30x60cm / 12"x24"
nat. rett. LGVTQ20 1500



40x60cm / 16"x24"
nat. rett. LGJTQ21 1500



60x60cm / 24"x24"
nat. rett. LGWTQ21 1500

hard black



20x30cm / 8"x12"
nat. rett. LGHTQ30 1500

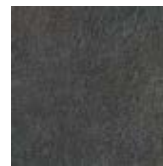

30x30cm / 12"x12"
nat. rett. LGCTQ30 1500



20x60cm / 8"x24"
nat. rett. LGKTQ30 1500



30x60cm / 12"x24"
nat. rett. LGVTQ30 1500

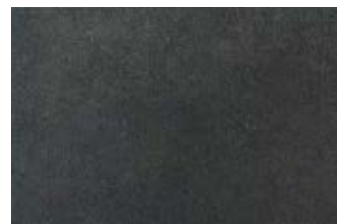

40x60cm / 16"x24"
nat. rett. LGJTQ31 1500



60x60cm / 24"x24"
nat. rett. LGWTQ31 1500

Tecnoquartz corredi e pezzi speciali

trims and decors / articles et pièces spéciales

formstücke und dekore / decorados y piezas especiales



LISTONE LINK
doral
30x60cm / 12"x24" LG9TQ39 1920



DECORO MURETTO
doral
30x60cm / 12"x24" LG9TQ32 1870



MOSAICO ANTICATO 7
doral
29,3x29,3cm / 11½"x11½" LG9TQ02 1840



LISTONE LINK
hot sand
30x60cm / 12"x24" LG9TQ54 1920



DECORO MURETTO
hot sand
30x60cm / 12"x24" LG9TQ57 1870

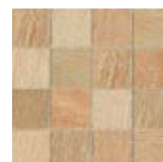

MOSAICO ANTICATO 7
hot sand
29,3x29,3cm / 11½"x11½" LG9TQ60 1840



LISTONE LINK
silver
30x60cm / 12"x24" LG9TQ40 1920



DECORO MURETTO
silver
30x60cm / 12"x24" LG9TQ33 1870



MOSAICO ANTICATO 7
silver
29,3x29,3cm / 11½"x11½" LG9TQ03 1840



LISTONE LINK
gneiss
30x60cm / 12"x24" LG9TQ38 1920



DECORO MURETTO
gneiss
30x60cm / 12"x24" LG9TQ34 1870



MOSAICO ANTICATO 7
gneiss
29,3x29,3cm / 11½"x11½" LG9TQ09 1840



LISTONE LINK
hard black
30x60cm / 12"x24" LG9TQ45 1920



DECORO MURETTO
hard black
30x60cm / 12"x24" LG9TQ48 1870

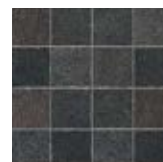

MOSAICO ANTICATO 7
hard black
29,3x29,3cm / 11½"x11½" LG9TQ51 1840



ANTI KATO 14
doral
14,5x14,5cm / 5^{3/4}"x5^{3/4}" LG9TQ04 1590



ANTI KATO 7x14
doral
7,1x14,5cm / 2^{3/4}"x5^{3/4}" LG9TQ06 1690



ANTI KATO 14
hot sand
14,5x14,5cm / 5^{3/4}"x5^{3/4}" LG9TQ55 1590



ANTI KATO 7x14
hot sand
7,1x14,5cm / 2^{3/4}"x5^{3/4}" LG9TQ56 1690



ANTI KATO 14
silver
14,5x14,5cm / 5^{3/4}"x5^{3/4}" LG9TQ05 1590



ANTI KATO 7x14
silver
7,1x14,5cm / 2^{3/4}"x5^{3/4}" LG9TQ07 1690



ANTI KATO 14
gneiss
14,5x14,5cm / 5^{3/4}"x5^{3/4}" LG9TQ28 1590



ANTI KATO 7x14
gneiss
7,1x14,5cm / 2^{3/4}"x5^{3/4}" LG9TQ29 1690



ANTI KATO 14
hard black
14,5x14,5cm / 5^{3/4}"x5^{3/4}" LG9TQ46 1590



ANTI KATO 7x14
hard black
7,1x14,5cm / 2^{3/4}"x5^{3/4}" LG9TQ47 1690

BEAK JOLLY
doral
1,2x1,2cm / 1/2"x1/2"
LG9TQ24 0230

RACCORDO JOLLY
doral
1,2x30cm / 1/2"x12"
LG9TQ26 0180

BEAK JOLLY
hot sand
1,2x1,2cm / 1/2"x1/2"
LG9TQ53 0230

RACCORDO JOLLY
hot sand
1,2x30cm / 1/2"x12"
LG9TQ61 0180

BEAK JOLLY
silver
1,2x1,2cm / 1/2"x1/2"
LG9TQ25 0230

RACCORDO JOLLY
silver
1,2x30cm / 1/2"x12"
LG9TQ27 0180

BEAK JOLLY
gneiss
1,2x1,2cm / 1/2"x1/2"
LG9TQ30 0230

RACCORDO JOLLY
gneiss
1,2x30cm / 1/2"x12"
LG9TQ31 0180

BEAK JOLLY
hard black
1,2x1,2cm / 1/2"x1/2"
LG9TQ44 0230

RACCORDO JOLLY
hard black
1,2x30cm / 1/2"x12"
LG9TQ52 0180

DECORO PLATINO
ang. matita
1,5x3cm / 5/8"x1^{3/16}"
LG9TQ21 0400

DECORO PLATINO
matita
3x30cm / 1^{3/16}"x12"
LG9TQ20 0220

DECORO PLATINO
ang. torelo
1,5x5cm / 5/8"x2"
LG9TQ13 0410

DECORO PLATINO
torello
5x30cm / 2"x12"
LG9TQ12 0380

DECORO PLATINO
ang. listello righe
2x6,5cm / 3/4"x2^{1/2}"
LG9TQ17 0450

DECORO PLATINO
listello righe
6,5x30cm / 2^{1/2}"x12"
LG9TQ16 0410

DECORO PLATINO
tozzetto righe
6,5x6,5cm / 2^{1/2}"x 2^{1/2}"
LG9TQ23 0300

DECORO RAME
ang. matita
1,5x3cm / 5/8"x1^{3/16}"
LG9TQ19 0400

DECORO RAME
matita
3x30cm / 1^{3/16}"x12"
LG9TQ18 0220

DECORO RAME
ang. torelo
1,5x5cm / 5/8"x2"
LG9TQ11 0410

DECORO RAME
torello
5x30cm / 2"x12"
LG9TQ10 0380

DECORO RAME
ang. listello righe
2x6,5cm / 3/4"x2^{1/2}"
LG9TQ15 0450

DECORO RAME
listello righe
6,5x30cm / 2^{1/2}"x12"
LG9TQ14 0410

DECORO RAME
tozzetto righe
6,5x6,5cm / 2^{1/2}"x 2^{1/2}"
LG9TQ22 0300

Tecnoquartz pezzi speciali

trims / pièces spéciales / formstücke / piezas especiales

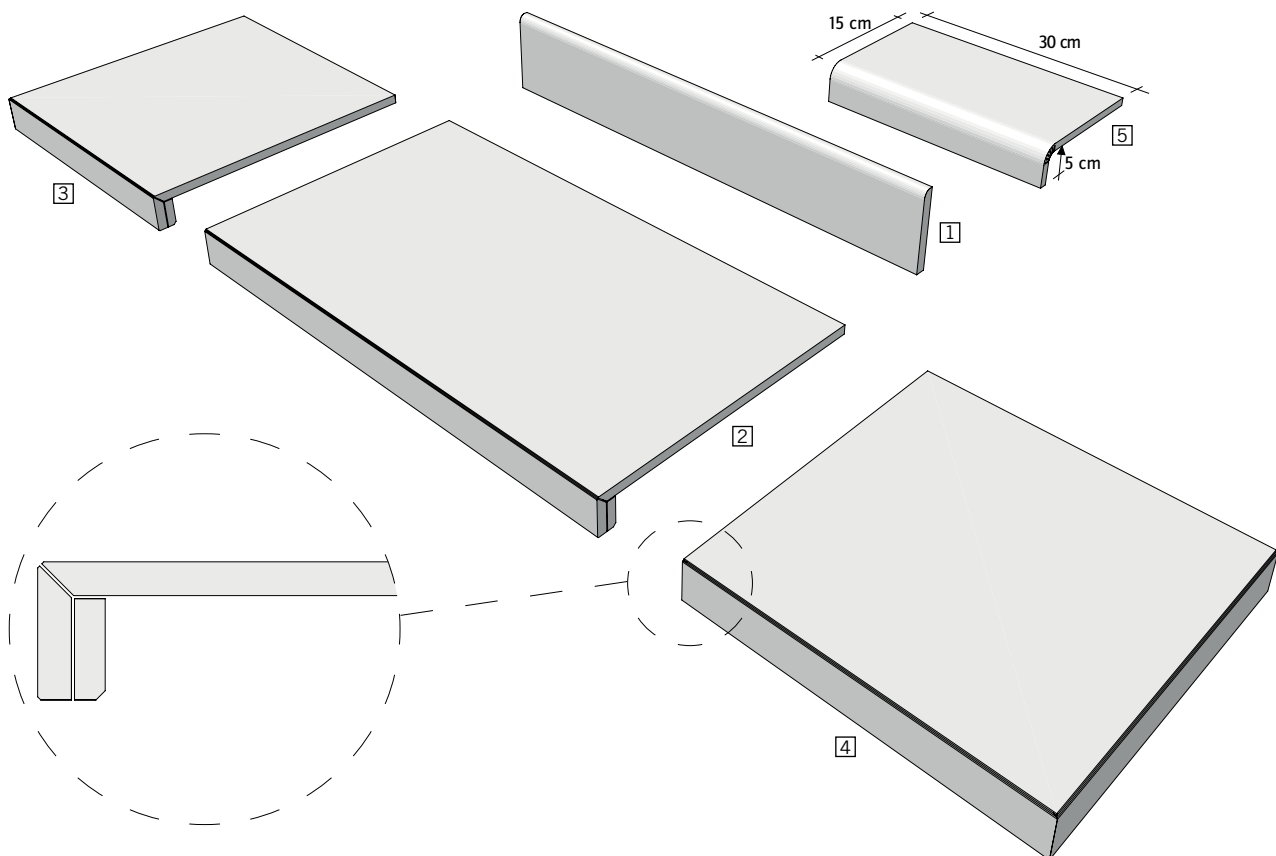

1 BATTISCOPIA

8x30cm / 3 1/8"x12"

doral	LGBTQ01 0100
hot sand	LGBTQ41 0100
silver	LGBTQ11 0100
gneiss	LGBTQ21 0100
hard black	LGBTQ31 0100

2 GRADINO PLUS

35x60cm / 13 3/4"x24"

doral	LG9TQP0 1630
hot sand	LG9TQP4 1630
silver	LG9TQP1 1630
gneiss	LG9TQP2 1630
hard black	LG9TQP3 1630

3 ANGOLO SX GRADINO PLUS

35x35cm / 13 3/4"x13 3/4"

doral	LG9TQS0 1970
hot sand	LG9TQS4 1970
silver	LG9TQS1 1970
gneiss	LG9TQS2 1970
hard black	LG9TQS3 1970

4 ANGOLO DX GRADINO PLUS

35x35cm / 13 3/4"x13 3/4"

doral	LG9TQD0 1970
hot sand	LG9TQD4 1970
silver	LG9TQD1 1970
gneiss	LG9TQD2 1970
hard black	LG9TQD3 1970

5 ELEMENTO A ELLE CONTINUO

5x15x30cm / 2"x6"x12"

doral	LG9TQ64 0510
hot sand	LG9TQ66 0510
silver	LG9TQ63 0510
gneiss	LG9TQ65 0510
hard black	LG9TQ67 0510

Tutti i gradini continui sono da posare esclusivamente in interno.

All steps are intended as "indoor use" only.

Tous les nez de marche sont à utiliser exclusivement à l'intérieur.

Alle Stufenplatten sind ausschließlich für die Verlegung im Innenbereich geeignet.

Todos los peldaños/huella son para colocación exclusivamente en interior.



tecn quartz doral 30x30cm / 12"x12" - tecn quartz doral mosaico anticato 7 29,3x29,3cm / 11 1/2"x11 1/2"
tecn quartz doral mosaico anticato 7x14 7,1x14,5cm / 2 3/4"x5 3/4" - tecn quartz doral mosaico anticato 14 14,5x14,5cm / 5 3/4"x5 3/4"

RAIN FOREST



Ash



Blue



Earth



White



Sand



15,9x15,9cm / 6 1/4" x 6 1/4"



32,2x32,2cm / 12 5/8" x 12 5/8"



32,2x48,5cm / 12 5/8" x 19"



48,5x48,5cm / 19" x 19"

Imballi pag. 432

Packing
Emballage
Verpackung
Embalajes

GRES SMALTATO GL

Glazed porcelain
Grès émaillé
Glesiertes Feinsteinzeug
Gres esmaltado GL

SPESSORE

Thickness
Epaisseur
Stärke
Espesor
10 mm

STONALIZZAZIONE

Shading
Denuançage
Spielfarbig
Grado de tonalización

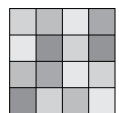

V4

FUGA MINIMA CONSIGLIATA

Minimum grout joint recommended
Joint minimum conseillé
Empfohlene Minimalfugenbreit
Distancia recomendada entre las baldosas
4 mm

RESISTENZA ALLO SCIVOLAMENTO DIN 51130

Slip resistance
Résistance au glissement
Rutschfestigkeit
Resistencia antideslizante
R10

COEFFICIENTE DI ATTRITO DINAMICO B.C.R. TORTUS

$\mu > 0,40$

RESISTENZA ALLO SCIVOLAMENTO DIN 51097

Slip resistance
Résistance au glissement
Rutschfestigkeit
Resistencia antideslizante
classe A

COEFFICIENT OF FRICTION ASTM C1028

dry - COF ≥ 0.60
wet - COF ≥ 0.60





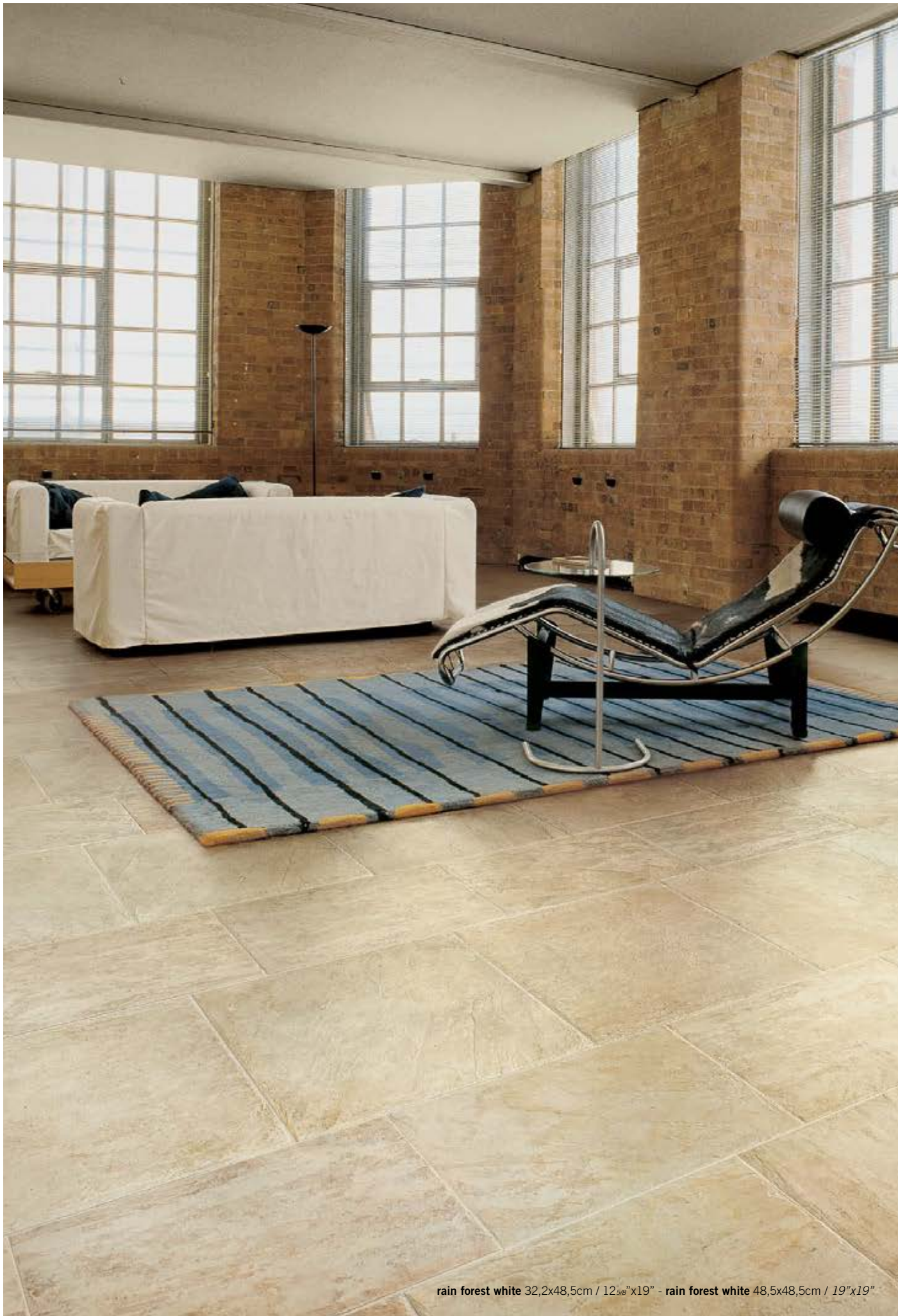

rain forest white 32,2x48,5cm / 12^{5/8}"x19" - rain forest white 48,5x48,5cm / 19"x19"

Rain Forest formati e colori

sizes and colors / formats et couleurs / formaten und farben / formatos y colores

white



15,9x15,9cm / 6 1/4"x6 1/4"
LGIRF2D 1000

sand



15,9x15,9cm / 6 1/4"x6 1/4"
LGIRF5D 1000

earth



15,9x15,9cm / 6 1/4"x6 1/4"
LGIRF3D 1000



32,2x32,2cm / 12 5/8"x12 5/8"
LGPRF2A 0860



32,2x32,2cm / 12 5/8"x12 5/8"
LGPRF5A 0860



32,2x32,2cm / 12 5/8"x12 5/8"
LGPRF3A 0860



32,2x48,5cm / 12 5/8"x19"
LGSRF2C 0930



32,2x48,5cm / 12 5/8"x19"
LGSRF5C 0930



32,2x48,5cm / 12 5/8"x19"
LGSRF3C 0930



48,5x48,5cm / 19"x19"
LGTRF2B 1010



48,5x48,5cm / 19"x19"
LGTRF5B 1010



48,5x48,5cm / 19"x19"
LGTRF3B 1010

blue



15,9x15,9cm / 6 1/4"x6 1/4"
LGIRF0D 1000

ash



15,9x15,9cm / 6 1/4"x6 1/4"
LGIRF6D 1000



32,2x32,2cm / 12 5/8"x12 5/8"
LGPRF0A 0860

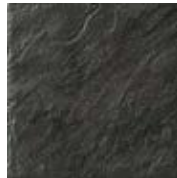

32,2x32,2cm / 12 5/8"x12 5/8"
LGPRF6A 0860



32,2x48,5cm / 12 5/8"x19"
LGSRF0C 0930



32,2x48,5cm / 12 5/8"x19"
LGSRF6C 0930



48,5x48,5cm / 19"x19"
LGTRF0B 1010



48,5x48,5cm / 19"x19"
LGTRF6B 1010

Rain Forest corredi e pezzi speciali

trims and decors / articles et pièces spéciales

formstücke und dekore / decorados y piezas especiales



MOSAICO 6
white
32,2x32,2cm / 12⁵/₈"x12⁵/₈"
LG9RFM2 1790



BEAK
white
2,8x2,8cm / 1¹/₈"x1¹/₈"
LG9RFB2 0160



QUARTER ROUND
white
2,8x6cm / 1¹/₈"x2³/₈"
LG9RFR2 0050



MOSAICO 6
earth
32,2x32,2cm / 12⁵/₈"x12⁵/₈"
LG9RFM3 1790



BEAK
earth
2,8x2,8cm / 1¹/₈"x1¹/₈"
LG9RFB3 0160



QUARTER ROUND
earth
2,8x6cm / 1¹/₈"x2³/₈"
LG9RFR3 0050



MOSAICO 6
ash
32,2x32,2cm / 12⁵/₈"x12⁵/₈"
LG9RFM6 1790



BEAK
ash
2,8x2,8cm / 1¹/₈"x1¹/₈"
LG9RFB6 0160



QUARTER ROUND
ash
2,8x6cm / 1¹/₈"x2³/₈"
LG9RFR6 0050



MOSAICO 6
sand
32,2x32,2cm / 12⁵/₈"x12⁵/₈"
LG9RFM5 1790



BEAK
sand
2,8x2,8cm / 1¹/₈"x1¹/₈"
LG9RFB5 0160



QUARTER ROUND
sand
2,8x6cm / 1¹/₈"x2³/₈"
LG9RFR5 0050



MOSAICO 6
blue
32,2x32,2cm / 12⁵/₈"x12⁵/₈"
LG9RFM0 1790



BEAK
blue
2,8x2,8cm / 1¹/₈"x1¹/₈"
LG9RFB0 0160



QUARTER ROUND
blue
2,8x6cm / 1¹/₈"x2³/₈"
LG9RFR0 0050

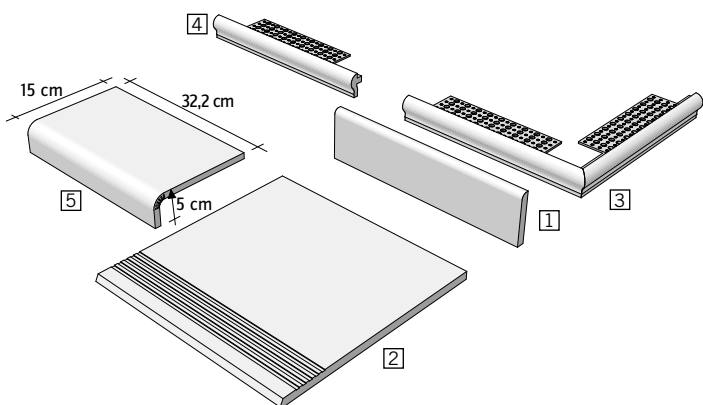

1 BATTISCOPIA
8x32,2cm / 3¹/₈"x12⁵/₈"
white LGBRFB2 0090
sand LGBRFB5 0090
earth LGBRFB3 0090
blue LGBRFB0 0090
ash LGBRFB6 0090

2 GRADINO STEP
32,2x32,2cm / 12⁵/₈"x12⁵/₈"
white LGCRFG2 0290
sand LGCRFG5 0290
earth LGCRFG3 0290
blue LGCRFG0 0290
ash LGCRFG6 0290

3 TORELLO GRADINO ANGOLO SU RETE
5,5x32,2cm / 2¹/₈"x12⁵/₈"
white LG9RFZ2 0960
sand LG9RFZ5 0960
earth LG9RFZ3 0960
blue LG9RFZ0 0960
ash LG9RFZ6 0960

4 TORELLO GRADINO BORDO SU RETE
5,5x32,2cm / 2¹/₈"x12⁵/₈"
white LG9RFT2 0580
sand LG9RFT5 0580
earth LG9RFT3 0580
blue LG9RFT0 0580
ash LG9RFT6 0580

5 ELEMENTO A ELLE CONTINUO
5x15x32,2cm / 2"x6"x12⁵/₈"
white LG9RFE2 0460
sand LG9RFE5 0460
earth LG9RFE3 0460
blue LG9RFE0 0460
ash LG9RFE6 0460



ANCIENT JERUSALEM

 Cedron Gold

 Ghion Beige

 Hebron White



15,9x15,9cm/6^{1/4}"x6^{1/4}"



15,9x32,2cm/6^{1/4}"x12^{5/8}"

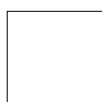

32,2x32,2cm/12^{5/8}"x12^{5/8}"



32,2x48,5cm/12^{5/8}"x19"

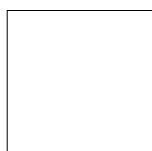

48,5x48,5cm/19"x19"

Imballi pag. 425

Packing
Emballage
Verpackung
Embalajes

GRES SMALTATO GL

Glazed porcelain
Grès émaillé
Glesiertes Feinsteinzeug
Gres esmaltado GL

SPESSORE

Thickness
Epaisseur
Stärke
Espesor
10 mm

STONALIZZAZIONE

Shading
Denuançage
Spielfarbig
Grado de tonalización

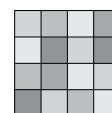

V4

FUGA MINIMA CONSIGLIATA

Minimum grout joint recommended
Joint minimum conseillé
Empfohlene Minimalfugenbreit
Distancia recomendada entre las baldosas
4 mm

RESISTENZA ALLO SCIVOLAMENTO DIN 51130

Slip resistance
Résistance au glissement
Rutschfestigkeit
Resistencia antideslizante
R9

COEFFICIENTE DI ATTRITO DINAMICO B.C.R. TORTUS

$\mu > 0,40$

RESISTENZA ALL'ABRASIONE SUPERFICIALE ISO 10545-7

Resistance to superficial abrasion
Résistance à l'abrasion superficielle
Oberflächliche reibungsbeständigkeit
Resistencia a la abrasión superficial
pei 5



ancient jerusalem mosaico 6 hebron white 32,2x32,2cm / 12^{5/8}"x12^{5/8}"



ancient jerusalem cedron gold 32,2x32,2cm / 12^{5/8}"x12^{5/8}" - ancient jerusalem mosaico 6 cedron gold 32,2x32,2cm / 12^{5/8}"x12^{5/8}"



ancient jerusalem gihon beige 15,9x15,9cm / 6¹/₄"x6¹/₄" - ancient jerusalem gihon beige 15,9x32,2cm / 6¹/₄"x12⁵/₈"
ancient jerusalem gihon beige 32,2x32,2cm / 12⁵/₈"x12⁵/₈" - ancient jerusalem gihon beige 32,2x48,5cm / 12⁵/₈"x19"
ancient jerusalem gihon beige 48,5x48,5cm / 19"x19"

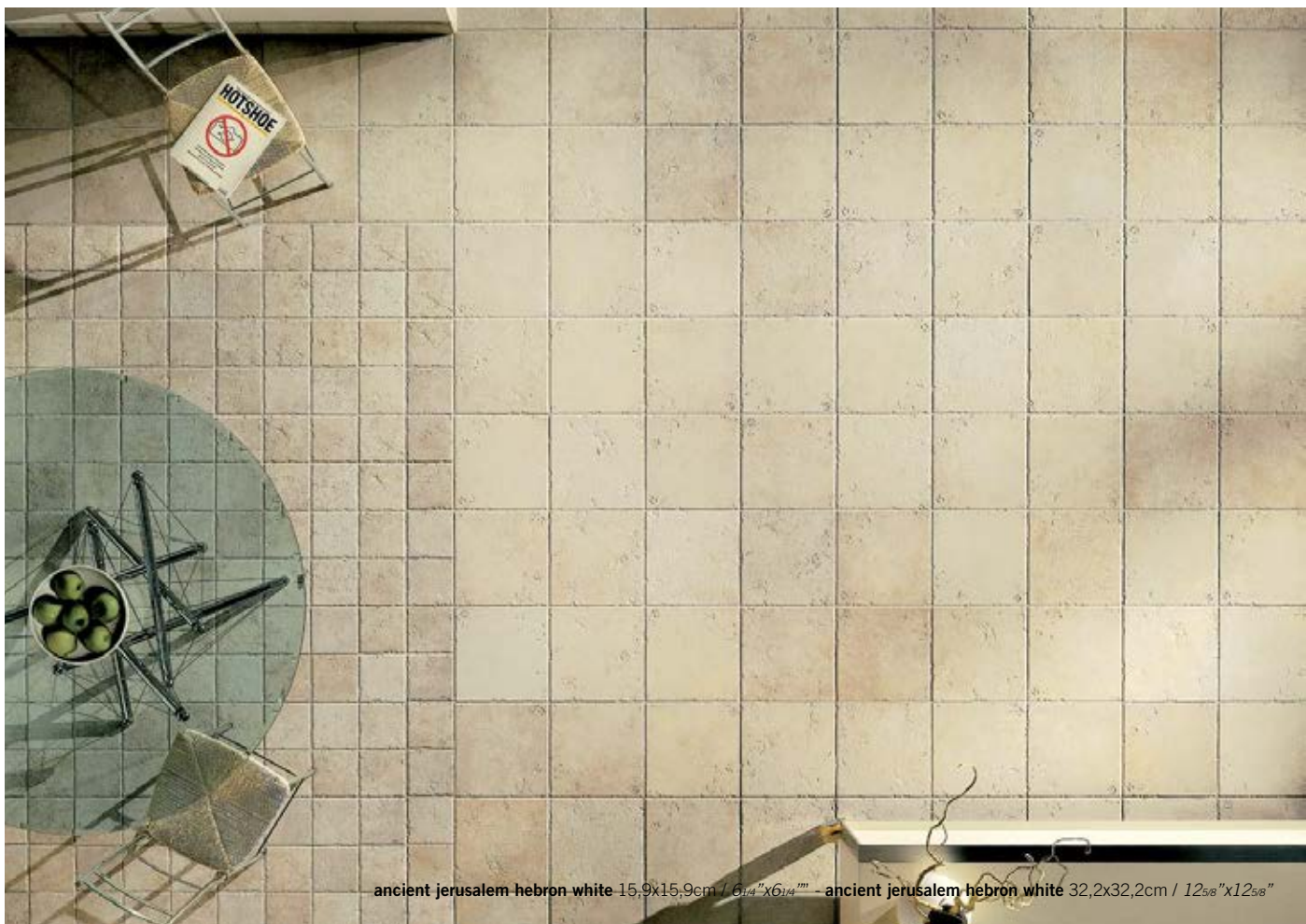

ancient jerusalem hebron white 15,9x15,9cm / 6¹/₄"x6¹/₄" - ancient jerusalem hebron white 32,2x32,2cm / 12⁵/₈"x12⁵/₈"

Ancient Jerusalem formati e colori

sizes and colors / formats et couleurs / formaten und farben / formatos y colores

hebron white



15,9x15,9cm / 6 1/4"x6 1/4"
LGIAY2D 0980



15,9x32,2cm / 6 1/4"x12 5/8"
LGHAY2E 0900



32,2x32,2cm / 12 5/8"x12 5/8"
LGPAY2A 0800



32,2x48,5cm / 12 5/8"x19"
LGSAY2A 0930



48,5x48,5cm / 19"x19"
LGTAY2B 1010

cedron gold



15,9x15,9cm / 6 1/4"x6 1/4"
LGIAY0D 0980



15,9x32,2cm / 6 1/4"x12 5/8"
LGHAY0E 0900



32,2x32,2cm / 12 5/8"x12 5/8"
LGPAY0A 0800



32,2x48,5cm / 12 5/8"x19"
LGSAY0A 0930



48,5x48,5cm / 19"x19"
LGTAY0B 1010

ghihon beige



15,9x15,9cm / 6 1/4"x6 1/4"
LGIAY1D 0980



15,9x32,2cm / 6 1/4"x12 5/8"
LGHAY1E 0900



32,2x32,2cm / 12 5/8"x12 5/8"
LGPAY1A 0800



32,2x48,5cm / 12 5/8"x19"
LGSAY1A 0930



48,5x48,5cm / 19"x19"
LGTAY1B 1010

Ancient Jerusalem corredi e pezzi speciali

trims and decors / articles et pièces spéciales

formstücke und dekore / decorados y piezas especiales



MOSAICO 6
hebron white
32,2x32,2cm / 12^{5/8}"x12^{5/8}"
LG9AY2M **1790**



BEAK
hebron white
2,8x2,8cm / 1^{1/8}"x1^{1/8}"
LG9AYB2 **0160**



QUARTER ROUND
hebron white
2,8x6cm / 1^{1/8}"x2^{3/8}"
LG9AYR2 **0050**



MOSAICO 6
cedron gold
32,2x32,2cm / 12^{5/8}"x12^{5/8}"
LG9AY0M **1790**



BEAK
cedron gold
2,8x2,8cm / 1^{1/8}"x1^{1/8}"
LG9AYB0 **0160**



QUARTER ROUND
cedron gold
2,8x6cm / 1^{1/8}"x2^{3/8}"
LG9AYR0 **0050**



MOSAICO 6
ghion beige
32,2x32,2cm / 12^{5/8}"x12^{5/8}"
LG9AY1M **1790**



BEAK
ghion beige
2,8x2,8cm / 1^{1/8}"x1^{1/8}"
LG9AYB1 **0160**



QUARTER ROUND
ghion beige
2,8x6cm / 1^{1/8}"x2^{3/8}"
LG9AYR1 **0050**

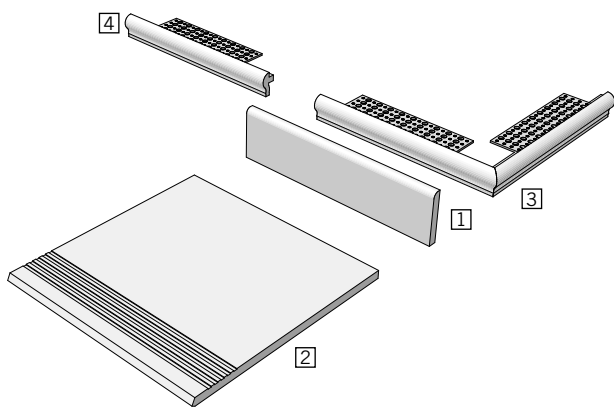

1 BATTISCOPIA
8x32,2cm / 3^{1/8}"x12^{5/8}"
hebron white
cedron gold
ghion beige

LGBAYB2 **0090**
LGBAYB0 **0090**
LGBAYB1 **0090**

2 GRADINO
32,2x32,2cm / 12^{5/8}"x12^{5/8}"
hebron white
cedron gold
ghion beige

LG CAYG2 **0290**
LG CAYG0 **0290**
LG CAYG1 **0290**

3 TORELLO GRADINO
ANGOLO SU RETE
5,5x32,2cm / 2^{1/8}"x12^{5/8}"
hebron white
cedron gold
ghion beige

LG9AYZ2 **0960**
LG9AYZ0 **0960**
LG9AYZ1 **0960**

4 TORELLO GRADINO
BORDO SU RETE
5,5x32,2cm / 2^{1/8}"x12^{5/8}"
hebron white
cedron gold
ghion beige

LG9AYT2 **0580**
LG9AYT0 **0580**
LG9AYT1 **0580**

ECOLEGNI

242

252

262

BIO TIMBER

BIO PLANK

BIOESSENZE

	Oak Patinato Chiaro		15x120cm/6"x48"
	Oak Patinato Scuro		20x120cm/8"x48"
	Oak Provenzale		
	Oak Grigio		
	Oak Grigio Scuro		

Imballi pag. 428
 Packing
 Emballage
 Verpackung
 Embalajes

GRES TUTTA MASSA UGL

Full-body porcelain
 Grès Cérame pleine masse
 Vollgemischtes Durchgefärbtes Feinsteinzeug
 Gres toda masa UGL

SPESSORE

Thickness
 Epaisseur
 Stärke
 Espesor
 11 mm

STONALIZZAZIONE

Shading
 Denuançage
 Spielfarbig
 Grado de tonalización

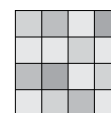

V3

FUGA MINIMA CONSIGLIATA

Minimum grout joint recommended
 Joint minimum conseillé
 Empfohlene Minimalfugenbreit
 Distancia recomendada entre las baldosas
 2 mm

**RESISTENZA ALLO SCIVOLAMENTO
 DIN 51130**

Slip resistance
 Résistance au glissement
 Rutschfestigkeit
 Resistencia antideslizante

R9

**COEFFICIENTE DI ATTRITO DINAMICO
 B.C.R. TORTUS**

$\mu > 0,40$

COEFFICIENT OF FRICTION

ASTM C1028
 dry - COF ≥ 0.60
 wet - COF ≥ 0.60

**DYNAMIC COEFFICIENT OF FRICTION
 BOT 3000**

DCOF ≥ 0.42

Info Microban pag. 396

ANTIBACTERIAL



bio timber oak grigio 15x120cm / 6"x48" - bio timber oak grigio 20x120cm / 8"x48"



bio timber oak patinato chiaro 20x120cm / 8"x48"



bio timber oak grigio scuro 20x120cm / 8"x48"

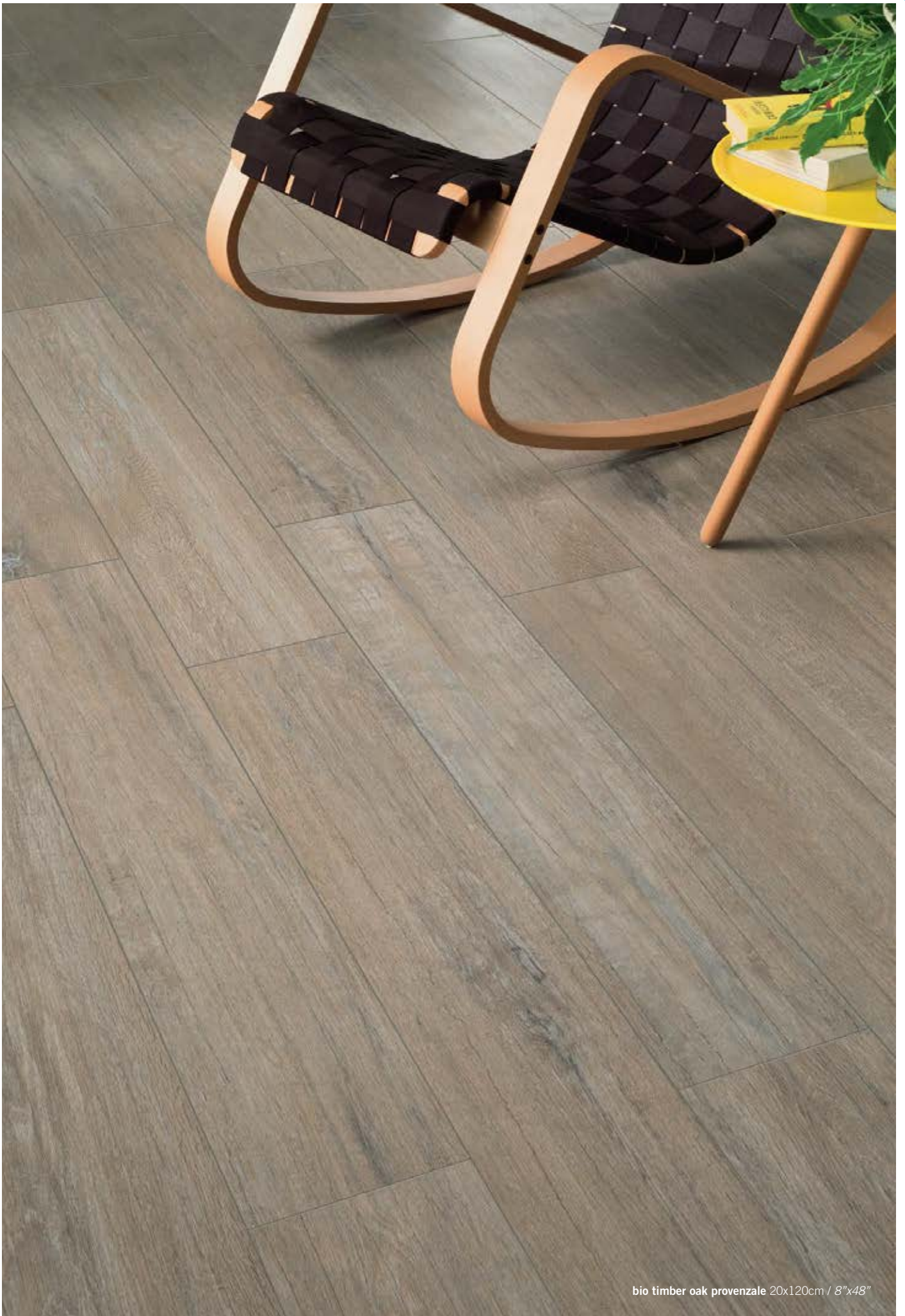

bio timber oak provenzale 20x120cm / 8"x48"



bio timber oak patinato chiaro 20x120cm / 8"x48" - bio timber oak patinato chiaro strip 20x120cm / 8"x48"



bio timber oak grigio mosaico wall 31x31cm / 12¹/₄"x12¹/₄"



bio timber oak patinato scuro 20x120cm / 8"x48" - bio timber oak patinato scuro 15x120cm / 6"x48"

Bio Timber formati e colori

sizes and colors / formats et couleurs / formaten und farben / formatos y colores

oak patinato chiaro



20x120cm / 8"x48"

LG7BI00 1285

oak patinato chiaro



15x120cm / 6"x48"

LGMBI00 1345

oak patinato scuro



20x120cm / 8"x48"

LG7BI10 1285

oak patinato scuro



15x120cm / 6"x48"

LGMBI10 1345

oak provenzale



20x120cm / 8"x48"

LG7BI20 1285

oak provenzale



15x120cm / 6"x48"

LGMBI20 1345

oak grigio



20x120cm / 8"x48"

LG7BI40 1285

oak grigio



15x120cm / 6"x48"

LGMBI40 1345

oak grigio scuro



20x120cm / 8"x48"

LG7BI30 1285

oak grigio scuro



15x120cm / 6"x48"

LGMBI30 1345



COMPASS
20x120cm / 8"x48"
oak patinato chiaro

LG7BIC0 1765



STRIP
20x120cm / 8"x48"
oak patinato chiaro

LG7BIS0 1635



COMPASS
20x120cm / 8"x48"
oak patinato scuro

LG7BIC1 1765



STRIP
20x120cm / 8"x48"
oak patinato scuro

LG7BIS1 1635



COMPASS
20x120cm / 8"x48"
oak provenzale

LG7BIC2 1765



STRIP
20x120cm / 8"x48"
oak provenzale

LG7BIS2 1635



COMPASS
20x120cm / 8"x48"
oak grigio

LG7BIC4 1765



STRIP
20x120cm / 8"x48"
oak grigio

LG7BIS4 1635



COMPASS
20x120cm / 8"x48"
oak grigio scuro

LG7BIC3 1765



STRIP
20x120cm / 8"x48"
oak grigio scuro

LG7BIS3 1635

Bio Timber corredi

decors / decors / dekore / decoros



TRIANGLES
20x120cm / 8"x48"
oak patinato chiaro

LG7BIT0 1765



TRIANGLES
20x120cm / 8"x48"
oak patinato scuro

LG7BIT1 1765



TRIANGLES
20x120cm / 8"x48"
oak provenzale

LG7BIT2 1765



TRIANGLES
20x120cm / 8"x48"
oak grigio

LG7BIT4 1765



TRIANGLES
20x120cm / 8"x48"
oak grigio scuro

LG7BIT3 1765



MOSAICO WALL
31x31cm / 12 1/4"x12 1/4"
oak patinato chiaro
LG9BIM0 2105



MOSAICO WALL
31x31cm / 12 1/4"x12 1/4"
oak patinato scuro
LG9BIM1 2105



MOSAICO WALL
31x31cm / 12 1/4"x12 1/4"
oak provenzale
LG9BIM2 2105



MOSAICO WALL
31x31cm / 12 1/4"x12 1/4"
oak grigio
LG9BIM4 2105



MOSAICO WALL
31x31cm / 12 1/4"x12 1/4"
oak grigio scuro
LG9BIM3 2105

Bio Timber pezzi speciali

trims / pièces spéciales / formstücke / piezas especiales

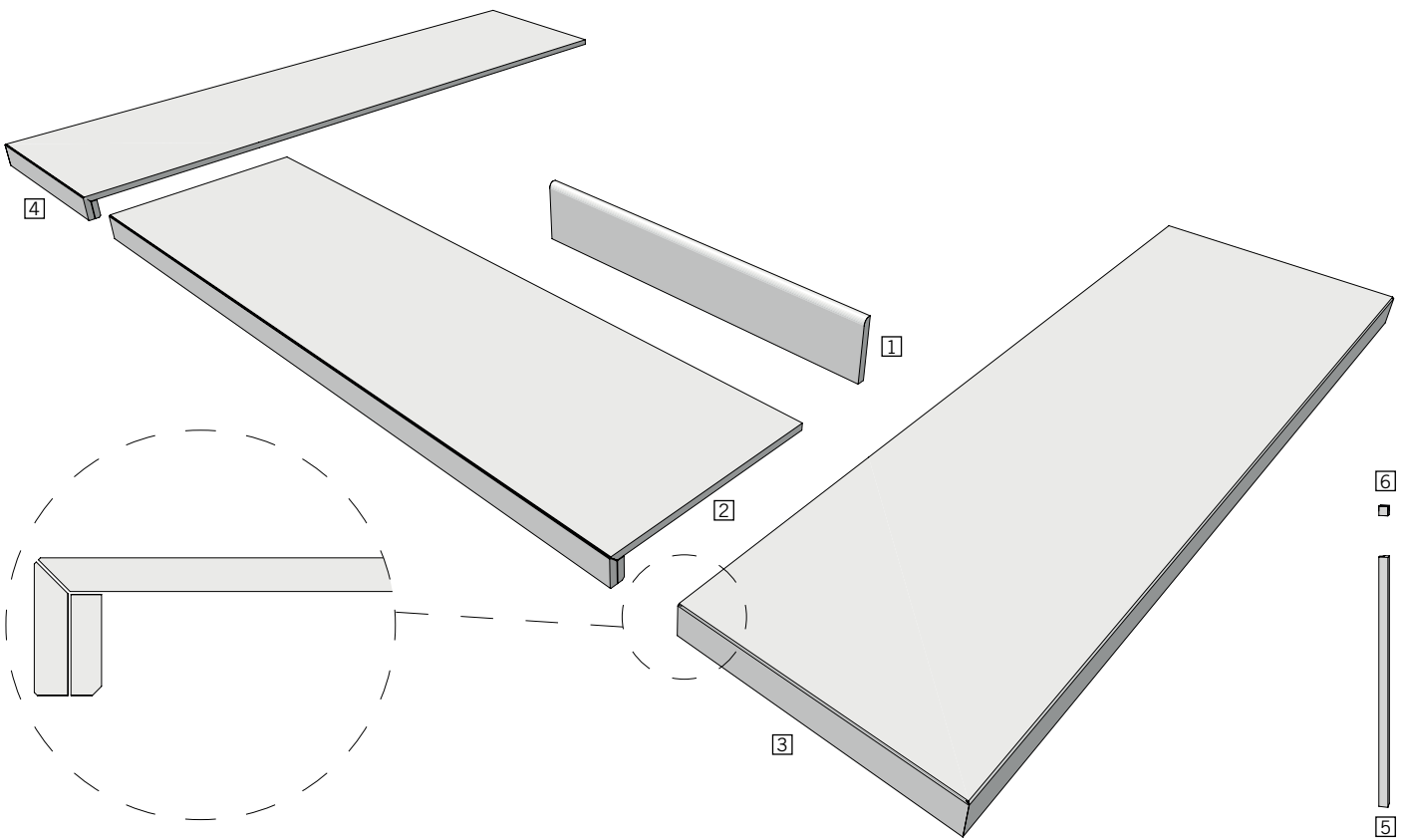

1 BATTISCOPA
 10x60cm / 4"x24"
 oak patinato chiaro
 oak patinato scuro
 oak provenzale
 oak grigio
 oak grigio scuro

LG9BII0 0230
 LG9BII1 0230
 LG9BII2 0230
 LG9BII4 0230
 LG9BII3 0230

2 GRADINO PLUS
 35x120cm / 13 3/4"x48"
 oak patinato chiaro
 oak patinato scuro
 oak provenzale
 oak grigio
 oak grigio scuro

LG9BIG0 1985
 LG9BIG1 1985
 LG9BIG2 1985
 LG9BIG4 1985
 LG9BIG3 1985

3 ANGOLO SX GRADINO PLUS
 35x120cm / 13 3/4"x48"
 oak patinato chiaro
 oak patinato scuro
 oak provenzale
 oak grigio
 oak grigio scuro

LG9BIS0 2125
 LG9BIS1 2125
 LG9BIS2 2125
 LG9BIS4 2125
 LG9BIS3 2125

4 ANGOLO DX GRADINO PLUS
 35x120cm / 13 3/4"x48"
 oak patinato chiaro
 oak patinato scuro
 oak provenzale
 oak grigio
 oak grigio scuro

LG9BID0 2125
 LG9BID1 2125
 LG9BID2 2125
 LG9BID4 2125
 LG9BID3 2125











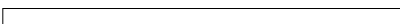

5 RACCORDO JOLLY
 1,3x30cm / 1/2"x12"
 oak patinato chiaro
 oak patinato scuro
 oak provenzale
 oak grigio
 oak grigio scuro

LG9BIJ0 0180
 LG9BIJ1 0180
 LG9BIJ2 0180
 LG9BIJ4 0180
 LG9BIJ3 0180

6 BEAK JOLLY
 1,3x2cm / 1/2"x3/4"
 oak patinato chiaro
 oak patinato scuro
 oak provenzale
 oak grigio
 oak grigio scuro

LG9BIK0 0260
 LG9BIK1 0260
 LG9BIK2 0260
 LG9BIK4 0260
 LG9BIK3 0260

BIO PLANK protezione antibatterica

	Cottage Brown		12x120cm/43/4"x48"
	Cottage Blue		15x120cm/6"x48"
	Fumè		
	Oak Noisette		20x120cm/8"x48"
	Oak Ice		
	Oak Lava		
	Deck Brown*		
	Deck Cinder*		
	Deck Fumè*		

*non trattato con antibatterico
without antimicrobial treatment
sans traitement antibactérien
nicht mit antibakterieller
Wirkung ausgestattet

Imballi pag. 427
Packing
Emballage
Verpackung
Embalajes

GRES TUTTA MASSA UGL

Full-body porcelain
Grès Cérame pleine masse
Vollgemischtes Durchgefärbtes Feinsteinzeug
Gres toda masa UGL

SPESSORE

Thickness
Épaisseur
Stärke
Espesor
11 mm

STONALIZZAZIONE

Shading
Denuançage
Spielfarbig
Grado de tonalización

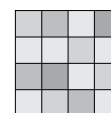

V3

FUGA MINIMA CONSIGLIATA

Minimum grout joint recommended
Joint minimum conseillé
Empfohlene Minimalfugenbreit
Distancia recomendada entre las baldosas
2 mm

RESISTENZA ALLO SCIVOLAMENTO DIN 51130

Slip resistance
Résistance au glissement
Rutschfestigkeit
Resistencia antideslizante

R9 (naturale)
R11 (deck)

COEFFICIENTE DI ATTRITO DINAMICO B.C.R. TORTUS

$\mu > 0,40$

BRITISH PENDULUM TEST BS 7976:2002

4S (slider 96)
dry: low slip potential PTV 36+ (naturale/deck)
wet: moderate slip potential PTV 25-35 (naturale)
low slip potential PTV 36+ (deck)

TRL (slider 55)
dry: low slip potential PTV 36+ (deck)
wet: low slip potential PTV 36+ (deck)

RESISTENZA ALLO SCIVOLAMENTO DIN 51097

Slip resistance
Résistance au glissement
Rutschfestigkeit
Resistencia antideslizante
classe C (deck)

COEFFICIENT OF FRICTION ASTM C1028

dry - COF ≥ 0.60
wet - COF ≥ 0.60

DYNAMIC COEFFICIENT OF FRICTION BOT 3000

DCOF ≥ 0.42

Info Microban pag. 396

ANTIBACTERIAL



bio plank oak ice 15x120cm / 6"x48" - bio plank oak ice 20x120cm / 8"x48"



bio plank oak noisette 15x120cm / 6"x48"



bio plank cottage brown 20x120cm / 8"x48" - bio plank decoro axe cottage 30x60cm / 12"x24"



bio plank oak lava 15x120cm / 6"x48" - bio plank oak lava 20x120cm / 8"x48"



bio plank cottage blue 20x120cm / 8"x48"



bio plank fumè 20x120cm / 8"x48"

Bio Plank formati e colori

sizes and colors / formats et couleurs / formaten und farben / formatos y colores

cottage brown



20x120cm / 8"x48"

LG7BP01 1285

deck brown*



12x120cm / 4 3/4"x48"

LG7BP90 1455

cottage blue



20x120cm / 8"x48"

LG7BP00 1285

deck cinder*



12x120cm / 4 3/4"x48"

LG7BP70 1455

fumè



20x120cm / 8"x48"

LG7BP50 1285

deck fumè*



12x120cm / 4 3/4"x48"

LG7BP80 1455

oak noisette



20x120cm / 8"x48"

LG7BP40 1285

oak noisette



15x120cm / 6"x48"

LGMBP40 1345

oak ice



20x120cm / 8"x48"

LG7BP30 1285

oak ice



15x120cm / 6"x48"

LGMBP30 1345

oak lava

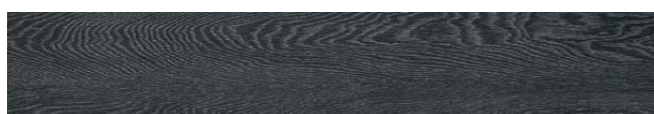

20x120cm / 8"x48"

LG7BP20 1285

oak lava



15x120cm / 6"x48"

LGMBP20 1345

*non trattato con antibatterico
without antimicrobial treatment
sans traitement antibactérien
nicht mit antibakterieller
Wirkung ausgestattet

Bio Plank corredi

decors / decors / dekore / decoros



DECORO FENCE**
20x120cm / 8"x48"
cottage brown

LG7BPF1 [0925](#)



DECORO AXE
30x60cm / 12"x24"
oak

LGVBPA4 [0665](#)



DECORO FENCE**
20x120cm / 8"x48"
cottage blue

LG7BPF0 [0925](#)



DECORO AXE
30x60cm / 12"x24"
cottage

LGVBPA0 [0665](#)



DECORO FENCE**
20x120cm / 8"x48"
fumè

LG7BPF5 [0925](#)



DECORO AXE
30x60cm / 12"x24"
harbor

LGVBPA4 [0665](#)



DECORO FENCE**
20x120cm / 8"x48"
oak noisette

LG7BPF4 [0925](#)



DECORO FENCE**
20x120cm / 8"x48"
oak ice

LG7BPF3 [0925](#)



DECORO FENCE**
20x120cm / 8"x48"
oak lava

LG7BPF2 [0925](#)

** su richiesta
upon request
sur demande
auf Anfrage

Bio Plank pezzi speciali

trims / pièces spéciales / formstücke / piezas especiales

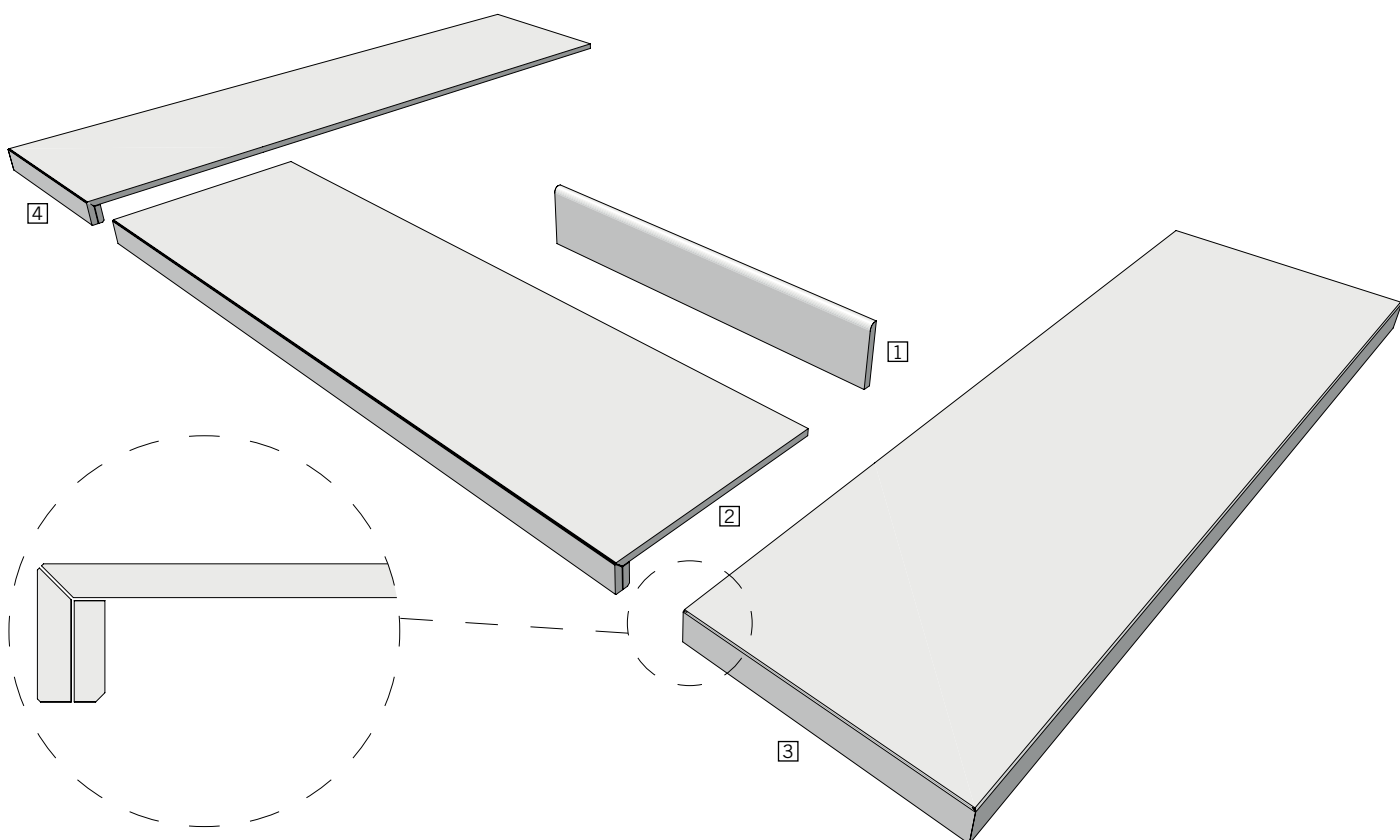

1 BATTISCOPIA
10x60cm / 4"x24"
cottage brown
cottage blue
fumè
oak noisette
oak ice
oak lava

LGBBPB1 [0230](#)
LGBBPB0 [0230](#)
LGBBPB5 [0230](#)
LGBBPB4 [0230](#)
LGBBPB3 [0230](#)
LGBBPB2 [0230](#)

2 GRADINO PLUS
35x120cm / 13 3/4"x48"
cottage brown
cottage blue
fumè
oak noisette
oak ice
oak lava

LG9BPP1 [1985](#)
LG9BPP0 [1985](#)
LG9BPP5 [1985](#)
LG9BPP4 [1985](#)
LG9BPP3 [1985](#)
LG9BPP2 [1985](#)

3 ANGOLO SX GRADINO PLUS
35x120cm / 13 3/4"x48"
cottage brown
cottage blue
fumè
oak noisette
oak ice
oak lava









LG9BPS1 [2125](#)
LG9BPS0 [2125](#)
LG9BPS5 [2125](#)
LG9BPS4 [2125](#)
LG9BPS3 [2125](#)
LG9BPS2 [2125](#)

4 ANGOLO DX GRADINO PLUS
35x120cm / 13 3/4"x48"
cottage brown
cottage blue
fumè
oak noisette
oak ice
oak lava

LG9BPD1 [2125](#)
LG9BPD0 [2125](#)
LG9BPD5 [2125](#)
LG9BPD4 [2125](#)
LG9BPD3 [2125](#)
LG9BPD2 [2125](#)



BIOESSENZE

 Rovere Bianco	 9x90cm/3 1/2"x36"
 Rovere Decapé	 15x120cm/6"x48"
 Rovere Naturale	
 Teak	 20x120cm/8"x48"
 Noce	

Imballi pag. 427
Packing
Emballage
Verpackung
Embalajes

GRES SMALTATO A MASSA COLORATA GL

Colored-body glazed porcelain
Grès émaillé a masse colorée
Glasiertes Feinsteinzeug mit farbiger masse
Gres esmaltado de masa colorada GL

FUGA MINIMA CONSIGLIATA

Minimum grout joint recommended
Joint minimum conseillé
Empfohlene Minimalfugenbreit
Distancia recomendada entre las baldosas
2 mm

RESISTENZA ALLO SCIVOLAMENTO DIN 51130

Slip resistance
Résistance au glissement
Rutschfestigkeit
Resistencia antideslizante
R9 (rovere bianco/rovere decapé)

RESISTENZA ALL'ABRASIONE SUPERFICIALE ISO 10545-7

Resistance to superficial abrasion
Résistance à l'abrasion superficielle
Oberflächliche reibungsbeständigkeit
Resistencia a la abrasión superficial
pei 5 (rovere bianco/rovere decapé/rovere naturale)
pei 4 (teak/noce)

SPESSORE

Thickness
Epaisseur
Stärke
Espesor
10 mm (teak)
12 mm

COEFFICIENTE DI ATTRITO DINAMICO B.C.R. TORTUS

$\mu > 0,40$ (rovere bianco/rovere decapé)

COEFFICIENT OF FRICTION ASTM C1028

dry - COF ≥ 0.60
wet - COF ≥ 0.60
(rovere bianco/rovere decapé)

STONALIZZAZIONE

Shading
Denuançage
Spielfarbig
Grado de tonalización

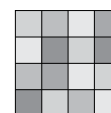

V4

RETTIFICATO MONOCALIBRO

Single caliber rectified
Monocalibre réctifié
Monokaliber rectifiziert
Rectificado monocálbre



IT / 021 / 010



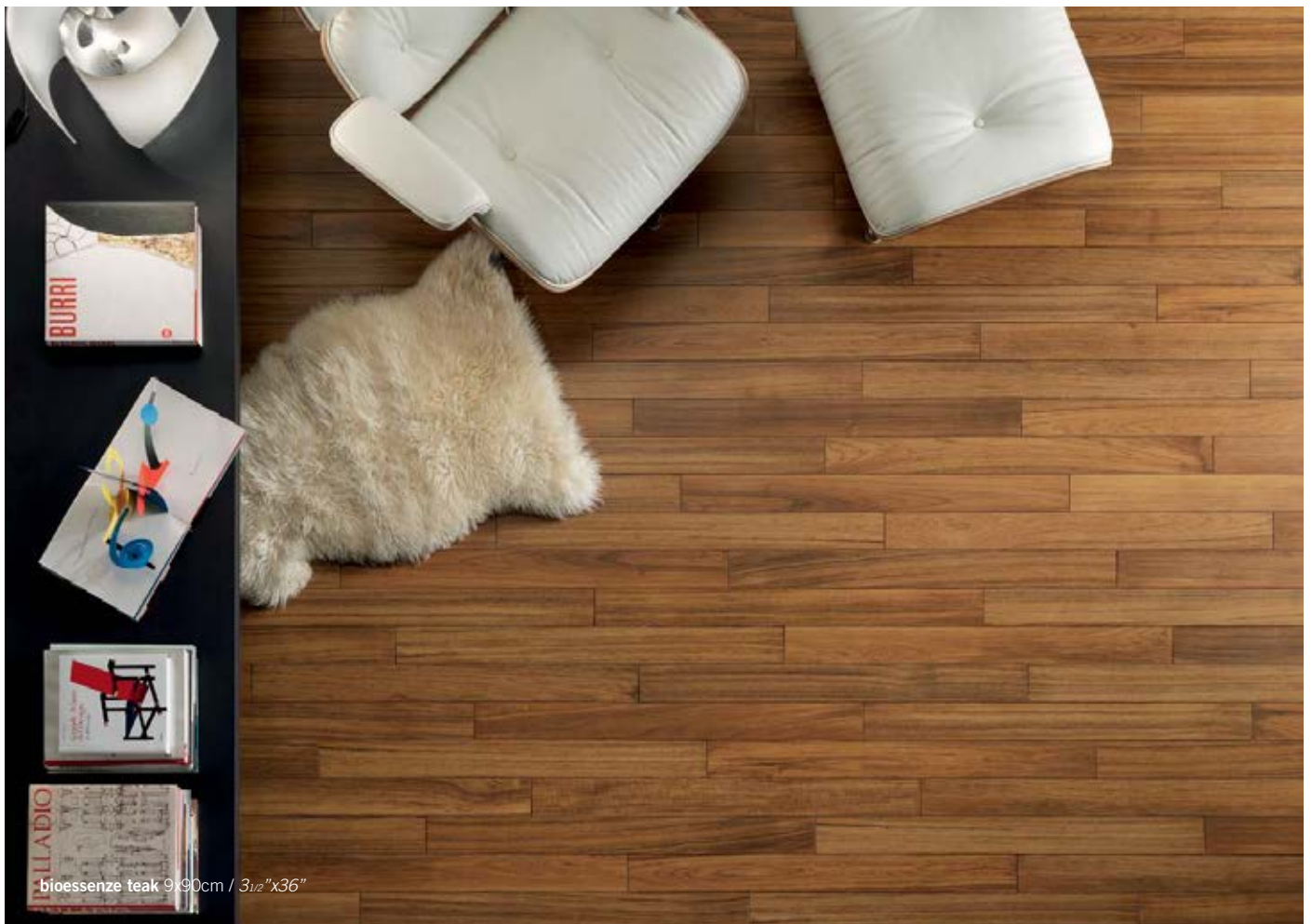

bioessenze teak 9x90cm / 3.12"x36"



bioessenze rovere bianco 15x120cm / 6"x48"



bioessenze rovere decapé 20x120cm / 8"x48"



bioessenze noce 15x120cm / 6"x48"

Bioessenze formati e colori

sizes and colors / formats et couleurs / formaten und farben / formatos y colores

rovere decapè



20x120cm / 8"x48"

LG7BZ20 1730

rovere bianco



15x120cm / 6"x48"

LGMBZ00 1730

rovere naturale



20x120cm / 8"x48"

LG7BZ50 1730

noce



15x120cm / 6"x48"

LGMBZ70 1730

teak



9x90cm / 3 1/2"x36"

LGNBZ40 1540

Bioessenze corredi

decors / decors / dekore / decoros



COMPOSIZIONE LISTELLO
30x60cm / 12"x24"
rovere bianco LG9BZ05 0570



DECORO INTRECCIO
30x30cm / 12"x12"
rovere bianco LG9BZ00 0670



DECORO CASSETTONE
60x60cm / 24"x24"
chiaro (rovere decapè/rovere bianco)
LG9BZ12 1350



COMPOSIZIONE LISTELLO
30x60cm / 12"x24"
noce LG9BZ19 0570

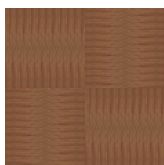

DECORO INTRECCIO
30x30cm / 12"x12"
noce LG9BZ16 0670

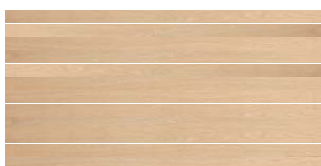

COMPOSIZIONE LISTELLO
30x60cm / 12"x24"
rovere decapè LG9BZ07 0570

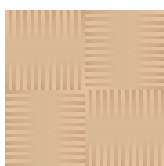

DECORO INTRECCIO
30x30cm / 12"x12"
rovere decapè LG9BZ02 0670

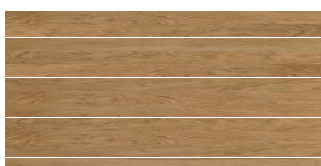

COMPOSIZIONE LISTELLO
30x60cm / 12"x24"
rovere naturale LG9BZ17 0570

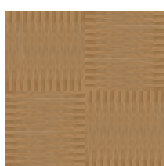

DECORO INTRECCIO
30x30cm / 12"x12"
rovere naturale LG9BZ14 0670



COMPOSIZIONE LISTELLO
30x60cm / 12"x24"
teak LG9BZ09 0570



DECORO INTRECCIO
30x30cm / 12"x12"
teak LG9BZ04 0670



COMPOSIZIONE LISTELLO
30x60cm / 12"x24"
chiaro (rovere decapè/rovere bianco)
LG9BZ10 0590

Bioessenze pezzi speciali

trims / pièces spéciales / formstücke / piezas especiales

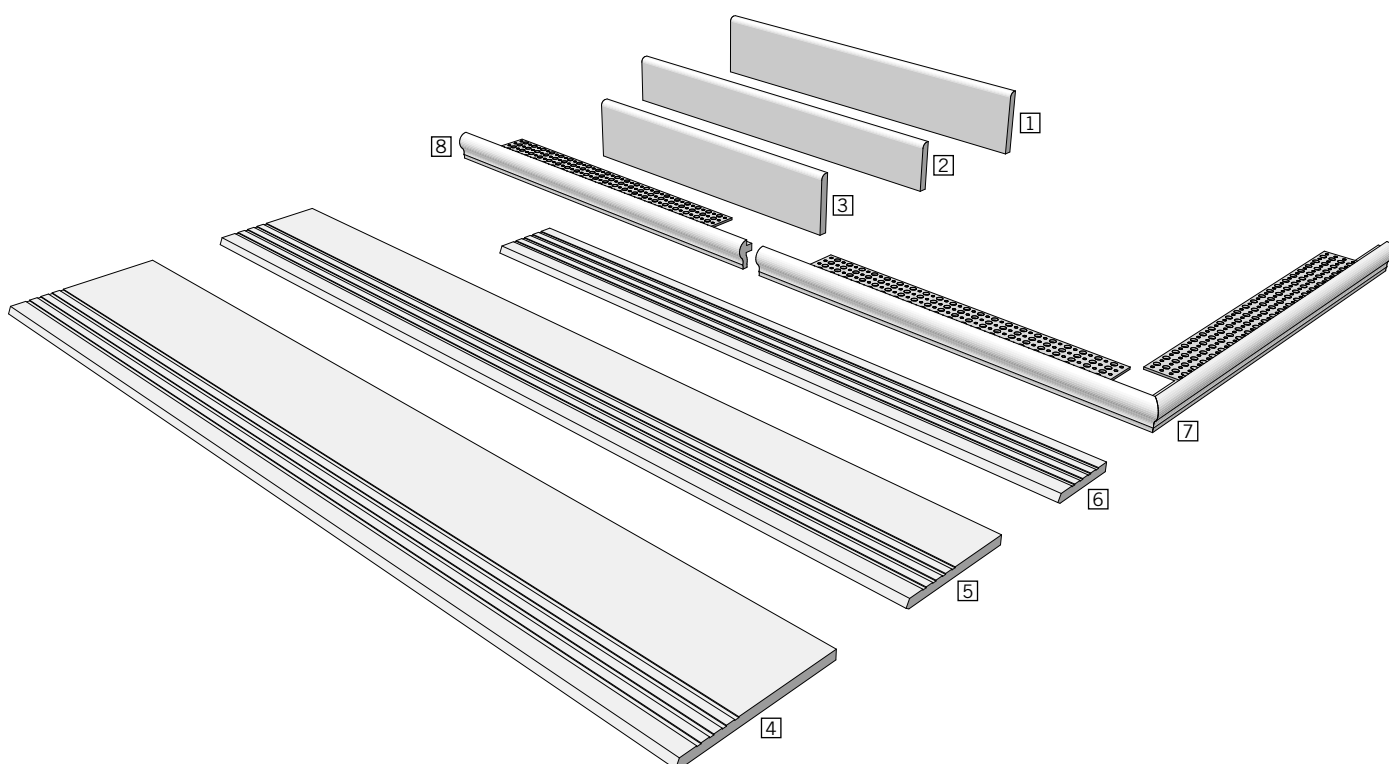

- | | | | | | |
|---|---|--|---|--|---------------------|
| <p>1 BATTISCOPIA
10x60cm / 4"x24"
rovere decapè
rovere naturale</p> | <p>LGBBZ20 0230
LGBBZ50 0230</p> | <p>2 BATTISCOPIA
7,5x60cm / 3"x24"
rovere bianco
noce</p> | <p>LGBBZ00 0230
LGBBZ70 0230</p> | <p>3 BATTISCOPIA
9x45cm / 3 1/2"x18"
teak</p> | <p>LGBBZ40 0230</p> |
| <p>4 GRADINO
20x120cm / 8"x48"
rovere decapè
rovere naturale</p> | <p>LGCBZ20 0850
LGCBZ50 0850</p> | <p>5 GRADINO
15x120cm / 6"x48"
rovere bianco
noce</p> | <p>LGCBZ00 0850
LGCBZ70 0850</p> | <p>6 GRADINO
9x90cm / 3 1/2"x36"
teak</p> | <p>LGCBZ40 0620</p> |
| <p>7 TORELLO GRADINO
ANGOLO SU RETE
4x60cm / 1 9/16"x24"
rovere bianco
noce
rovere decapè
rovere naturale
teak</p> | <p>LG9BZ30 1550
LG9BZ37 1550
LG9BZ32 1550
LG9BZ35 1550
LG9BZ34 1550</p> | <p>8 TORELLO GRADINO
BORDO SU RETE
4x60cm / 1 9/16"x24"
rovere bianco
noce
rovere decapè
rovere naturale
teak</p> | <p>LG9BZ20 0780
LG9BZ27 0780
LG9BZ22 0780
LG9BZ25 0780
LG9BZ24 0780</p> | | |



RIVESTIMENTI

272	KENSINGTON
284	MAYFAIR
292	KALOS
300	ATHENA
306	PLEASURES
314	AUDREY
326	TRÈS JOLIE
332	PROGETTO L14
340	GOCCIA
348	PAILLETES
354	TESSERAE

KENSINGTON

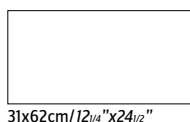
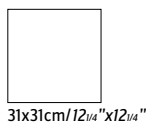
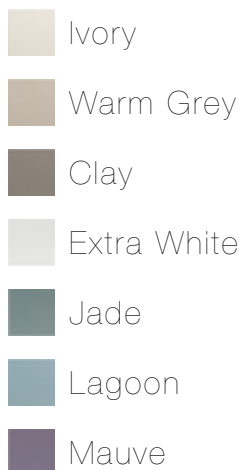

Imballi pag. 429
Packing
Emballage
Verpackung
Embalajes

MONOPOROSA IN PASTA BIANCA SMALTATA GL
Glazed white-body porous single-fired tiles
Monocuissons en pâte blanche émaillé
Weißscherbige monoporosa
Monoporosa de pasta blanca esmaltada GL

FUGA MINIMA CONSIGLIATA
Minimum grout joint recommended
Joint minimum conseillé
Empfohlene Minimalfugenbreit
Distancia recomendada entre las baldosas
1 mm

**RESISTENZA ALL'ABRASIONE SUPERFICIALE
ISO 10545-7**
Resistance to superficial abrasion
Résistance à l'abrasion superficielle
Oberflächliche reibungsbeständigkeit
Resistencia a la abrasión superficial
pei 4 (31x31)

SPESSORE
Thickness
Epaisseur
Stärke
Espesor
10 mm (rivestimento 31x62)
7,8 mm (pavimento 31x31)

STONALIZZAZIONE
Shading
Denuançage
Spielfarbig
Grado de tonalización

ONLY 31x31 GRES SMALTATO GL
Glazed stoneware
Grès émaillé
Glasiertes Feinsteinzeug
Gres esmaltado

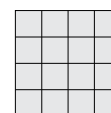





kensington plank lagoon 31x62cm / 12 $\frac{1}{4}$ "x24 $\frac{1}{2}$ " - kensington listello decò lagoon 7,5x31cm / 3"x12 $\frac{1}{4}$ "
slimtech gouache.10 deep sea 100x100cm / 39"x39"



kensington clay 31x62cm / 12 $\frac{1}{4}$ "x24 $\frac{1}{2}$ " - kensington listello decò clay 7,5x31cm / 3"x12 $\frac{1}{4}$ "



kensington brick ivory 31x62cm / 12¹/₄"x24¹/₂" - kensington raccordo jolly ivory 1,3x31cm / 1/2"x12¹/₄"



kensington mauve 31x62cm / 12¹/₄"x24¹/₂" - kensington raccordo jolly mauve 1,3x31cm / 1/2"x12¹/₄"
 mauk cuadra bsp slimtech plus sabbia - naturale - lappata 57,6cm / 22⁵/₈"



kensington jewel warm grey 31x62cm / 12¹/₄"x24¹/₂"



kensington jewel jade 31x62cm / 12¹/₄"x24¹/₂" - kensington cornice in legno rovere spazzolato chiaro 9x62cm / 3¹/₂"x24¹/₂"
bioessenze rovere bianco 15x120cm / 6"x48"

Kensington formati e colori

sizes and colors / formats et couleurs / formaten und farben / formatos y colores

ivory



ivory
31x62cm / 12 1/4"x24 1/2" (spessore 10mm)

LBAKS40 0885

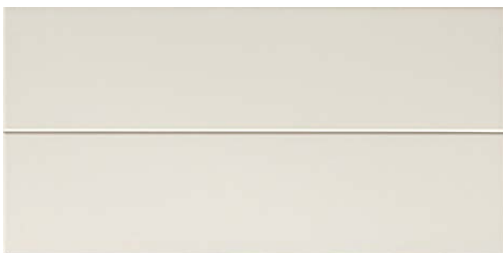

PLANK
ivory
31x62cm / 12 1/4"x24 1/2" (spessore 10mm)

LBAKS4P 0945



JEWEL
ivory
31x62cm / 12 1/4"x24 1/2" (spessore 13mm)

LBAKS4J 1175

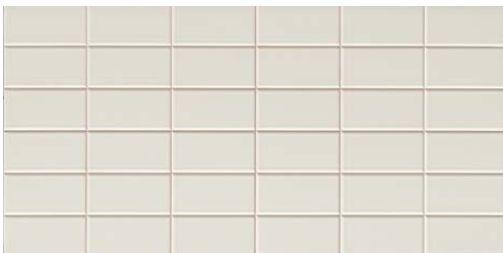

BRICK (5x10)
ivory
31x62cm / 12 1/4"x24 1/2" (spessore 10mm)

LBAKS4B 1005



SQUARE (7,5x7,5)
ivory
31x62cm / 12 1/4"x24 1/2" (spessore 11,5mm)

LBAKS4S 1175



LISTELLO DECÒ
ivory
7,5x31cm / 3"x12 1/4" LPZKS40 0305



GIROSPECCHIO DECÒ
ivory
7,5x7,5cm / 3"x3" LPZKS4G 0360



CORNICE IN LEGNO
rovere spazzolato scuro
9x62cm / 3 1/2"x24 1/2"

LG9KS00 0790

BEAK
ivory
1,3x1,3cm / 1/2"x1/2" LPZKS4B 0310



RACCORDO JOLLY
ivory
1,3x31cm / 1/2"x12 1/4" LPZKS4R 0220



ivory
31x31cm / 12 1/4"x12 1/4" LGPKS40 0725
(spessore 7,8mm)

Kensington formati e colori

sizes and colors / formats et couleurs / formaten und farben / formatos y colores

warm grey



warm grey
31x62cm / 12 1/4" x 24 1/2" (spessore 10mm)

LBAKS30 0885



PLANK
warm grey
31x62cm / 12 1/4" x 24 1/2" (spessore 10mm)

LBAKS3P 0945



JEWEL
warm grey
31x62cm / 12 1/4" x 24 1/2" (spessore 13mm)

LBAKSJ 1175

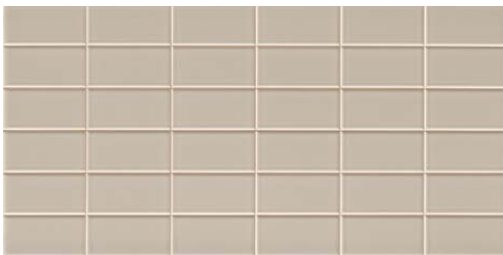

BRICK (5x10)
warm grey
31x62cm / 12 1/4" x 24 1/2" (spessore 10mm)

LBAKS3B 1005



SQUARE (7,5x7,5)
warm grey
31x62cm / 12 1/4" x 24 1/2" (spessore 11,5mm)

LBAKS3S 1175



LISTELLO DECÒ
warm grey
7,5x31cm / 3" x 12 1/4" LPZKS30 0305



GIROSPECCHIO DECÒ
warm grey
7,5x7,5cm / 3" x 3" LPZKS3G 0360



CORNICE IN LEGNO
rovere spazzolato scuro
9x62cm / 3 1/2" x 24 1/2" LG9KS00 0790

BEAK
warm grey
1,3x1,3cm / 1/2" x 1/2" LPZKS3B 0310



RACCORDO JOLLY
warm grey
1,3x31cm / 1/2" x 12 1/4" LPZKS3R 0220



warm grey
31x31cm / 12 1/4" x 12 1/4" LGPKS30 0725
(spessore 7,8mm)

clay



clay
31x62cm / 12 1/4" x 24 1/2"



PLANK
clay
31x62cm / 12 1/4" x 24 1/2" (spessore 10mm) **LBAKS5P 0945**



JEWEL
clay
31x62cm / 12 1/4" x 24 1/2" (spessore 13mm) **LBAKS5J 1175**



BRICK (5x10)
clay
31x62cm / 12 1/4" x 24 1/2" (spessore 10mm) **LBAKS5B 1005**



SQUARE (7,5x7,5)
clay
31x62cm / 12 1/4" x 24 1/2" (spessore 11,5mm) **LBAKS5S 1175**



LISTELLO DECÒ
clay
7,5x31cm / 3" x 12 1/4" **LPZKS50 0305**



GIROSPECCHIO DECÒ
clay
7,5x7,5cm / 3" x 3" **LPZKS5G 0360**



CORNICE IN LEGNO
rovere spazzolato scuro
9x62cm / 3 1/2" x 24 1/2" **LG9KS00 0790**



BEAK
clay
1,3x1,3cm / 1/2" x 1/2" **LPZKS5B 0310**



RACCORDO JOLLY
clay
1,3x31cm / 1/2" x 12 1/4" **LPZKS5R 0220**



clay
31x31cm / 12 1/4" x 12 1/4" **LGPKS50 0725**
(spessore 7,8mm)

Kensington formati e colori

sizes and colors / formats et couleurs / formaten und farben / formatos y colores

extra white



extra white
31x62cm / 12 1/4" x 24 1/2" (spessore 10mm)

LBAKS60 0885



PLANK
extra white
31x62cm / 12 1/4" x 24 1/2" (spessore 10mm)

LBAKS6P 0945



JEWEL
extra white
31x62cm / 12 1/4" x 24 1/2" (spessore 13mm)

LBAKS6J 1175

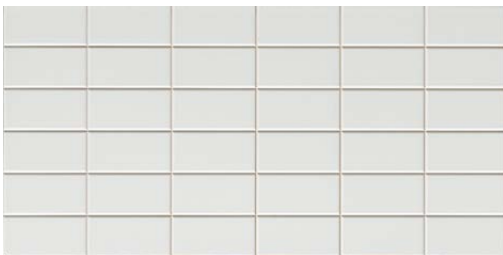

BRICK (5x10)
extra white
31x62cm / 12 1/4" x 24 1/2" (spessore 10mm)

LBAKS6B 1005



SQUARE (7,5x7,5)
extra white
31x62cm / 12 1/4" x 24 1/2" (spessore 11,5mm)

LBAKS6S 1175



LISTELLO DECÒ
extra white
7,5x31cm / 3" x 12 1/4" LPZKS60 0305



GIROSPECCHIO DECÒ
extra white
7,5x7,5cm / 3" x 3" LPZKS6G 0360

BEAK
extra white
1,3x1,3cm / 1/2" x 1/2" LPZKS6B 0310

RACCORDO JOLLY
extra white
1,3x31cm / 1/2" x 12 1/4" LPZKS6R 0220



extra white
31x31cm / 12 1/4" x 12 1/4" LGPKS60 0725
(spessore 7,8mm)



CORNICE IN LEGNO
rovere spazzolato scuro
9x62cm / 3 1/2" x 24 1/2" LG9KS00 0790

jade



jade
31x62cm / 12 1/4" x 24 1/2" (spessore 10mm) LBAKS00 0885



PLANK
jade
31x62cm / 12 1/4" x 24 1/2" (spessore 10mm) LBAKS0P 0945



JEWEL
jade
31x62cm / 12 1/4" x 24 1/2" (spessore 13mm) LBAKS0J 1175

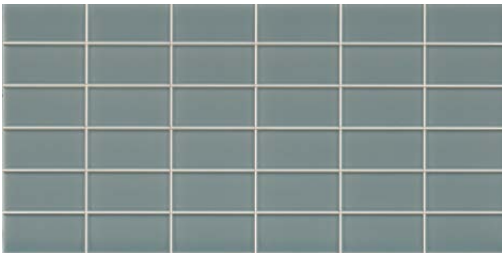

BRICK (5x10)
jade
31x62cm / 12 1/4" x 24 1/2" (spessore 10mm) LBAKS0B 1005



SQUARE (7,5x7,5)
jade
31x62cm / 12 1/4" x 24 1/2" (spessore 11,5mm) LBAKS0S 1175



LISTELLO DECÒ
jade
7,5x31cm / 3" x 12 1/4" LPZKS00 0305



GIROSPECCHIO DECÒ
jade
7,5x7,5cm / 3" x 3" LPZKS0G 0360



CORNICE IN LEGNO
rovere spazzolato chiaro
9x62cm / 3 1/2" x 24 1/2" LG9KS10 0790



BEAK
jade
1,3x1,3cm / 1/2" x 1/2" LPZKS0B 0310



RACCORDO JOLLY
jade
1,3x31cm / 1/2" x 12 1/4" LPZKS0R 0220



jade
31x31cm / 12 1/4" x 12 1/4" LGPKS00 0725
(spessore 7,8mm)

Kensington formati e colori

sizes and colors / formats et couleurs / formaten und farben / formatos y colores

lagoon



lagoon
31x62cm / 12 1/4" x 24 1/2" (spessore 10mm) LBAKS20 0885



PLANK
lagoon
31x62cm / 12 1/4" x 24 1/2" (spessore 10mm) LBAKS2P 0945

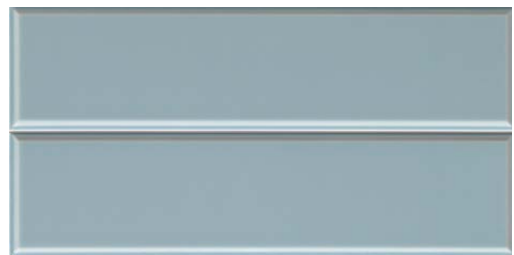

JEWEL
lagoon
31x62cm / 12 1/4" x 24 1/2" (spessore 13mm) LBAKS2J 1175

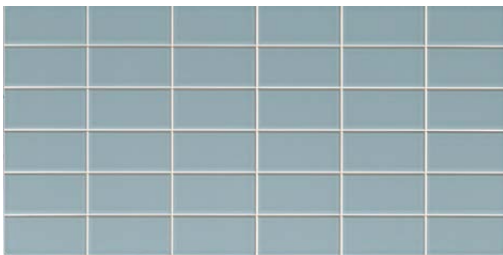

BRICK (5x10)
lagoon
31x62cm / 12 1/4" x 24 1/2" (spessore 10mm) LBAKS2B 1005



SQUARE (7,5x7,5)
lagoon
31x62cm / 12 1/4" x 24 1/2" (spessore 11,5mm) LBAKS2S 1175



LISTELLO DECÒ
lagoon
7,5x31cm / 3" x 12 1/4" LPZKS20 0305



GIROSPECCHIO DECÒ
lagoon
7,5x7,5cm / 3" x 3" LPZKS2G 0360



BEAK
lagoon
1,3x1,3cm / 1/2" x 1/2" LPZKS2B 0310



CORNICE IN LEGNO
rovere spazzolato chiaro
9x62cm / 3 1/2" x 24 1/2" LG9KS10 0790



RACCORDO JOLLY
lagoon
1,3x31cm / 1/2" x 12 1/4" LPZKS2R 0220

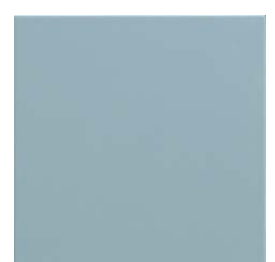

lagoon
31x31cm / 12 1/4" x 12 1/4" LGPKS20 0725
(spessore 7,8mm)

mauve

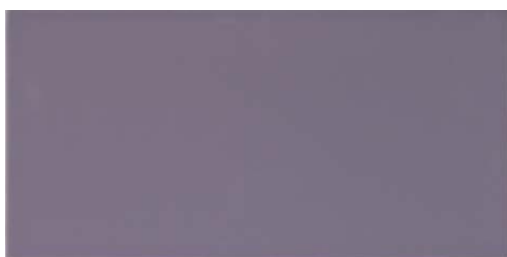

mauve
31x62cm / 12 1/4" x 24 1/2" (spessore 10mm)

LBAKS10 0885

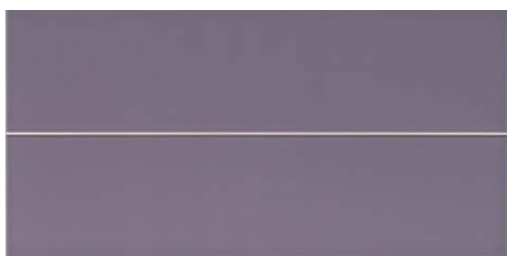

PLANK
mauve
31x62cm / 12 1/4" x 24 1/2" (spessore 10mm)

LBAKS1P 0945

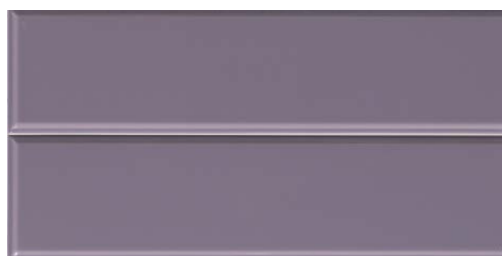

JEWEL
mauve
31x62cm / 12 1/4" x 24 1/2" (spessore 13mm)

LBAKS1J 1175

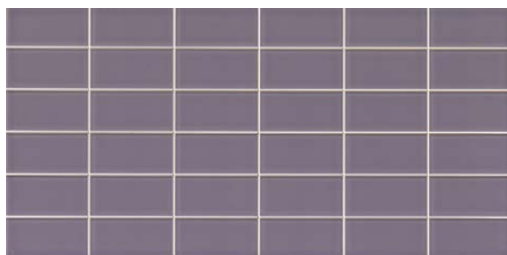

BRICK (5x10)
mauve
31x62cm / 12 1/4" x 24 1/2" (spessore 10mm)

LBAKS1B 1005



SQUARE (7,5x7,5)
mauve
31x62cm / 12 1/4" x 24 1/2" (spessore 11,5mm)

LBAKS1S 1175



LISTELLO DECÒ
mauve
7,5x31cm / 3" x 12 1/4" LPZKS10 0305



GIROSPECCHIO DECÒ
mauve
7,5x7,5cm / 3" x 3" LPZKS1G 0360



CORNICE IN LEGNO
rovere spazzolato chiaro
9x62cm / 3 1/2" x 24 1/2"

LG9KS10 0790

BEAK
mauve
1,3x1,3cm / 1/2" x 1/2" LPZKS1B 0310



RACCORDO JOLLY
mauve
1,3x31cm / 1/2" x 12 1/4" LPZKS1R 0220



mauve
31x31cm / 12 1/4" x 12 1/4" LGPKS10 0725
(spessore 7,8mm)

MAYFAIR

 Extra White

 Ivory

 Warm Grey

 Jade

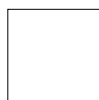

31x31cm/12^{1/4}"x12^{1/4}"



31x62cm/12^{1/4}"x24^{1/2}"

Imballi pag. 430

Packing
Emballage
Verpackung
Embalajes

MONOPOROSA IN PASTA BIANCA SMALTATA GL

Glazed white-body porous single-fired tiles
Monocuissons en pâte blanche émaillé
Weißscherbige monoporosa
Monoporosa de pasta blanca esmaltada GL

FUGA MINIMA CONSIGLIATA

Minimum grout joint recommended
Joint minimum conseillé
Empfohlene Minimalfugenbreit
Distancia recomendada entre las baldosas

1 mm

RESISTENZA ALL'ABRASIONE SUPERFICIALE ISO 10545-7

Resistance to superficial abrasion
Résistance à l'abrasion superficielle
Oberflächliche reibungsbeständigkeit
Resistencia a la abrasión superficial

pei 4 (31x31)

SPESSORE

Thickness
Epaisseur
Stärke
Espesor

10 mm (rivestimento 31x62)
7,8 mm (pavimento 31x31)

STONALIZZAZIONE

Shading
Denuançage
Spielfarbig
Grado de tonalización

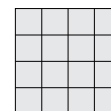

V1

ONLY 31x31 GRES SMALTATO GL

Glazed stoneware
Grès émaillé
Glasiertes Feisteinzeug
Gres esmaltado



mayfair extra white 31x62cm / 12¹/₄"x24¹/₂" - mayfair style lux warm grey 15x62cm / 6"x24¹/₂"
mayfair bacchetta platinum 1x62cm / 3/8"x24¹/₂" - mayfair jewel warm grey 31x62cm / 12¹/₄"x24¹/₂"
mayfair extra white 31x31cm / 12¹/₄"x12¹/₄"



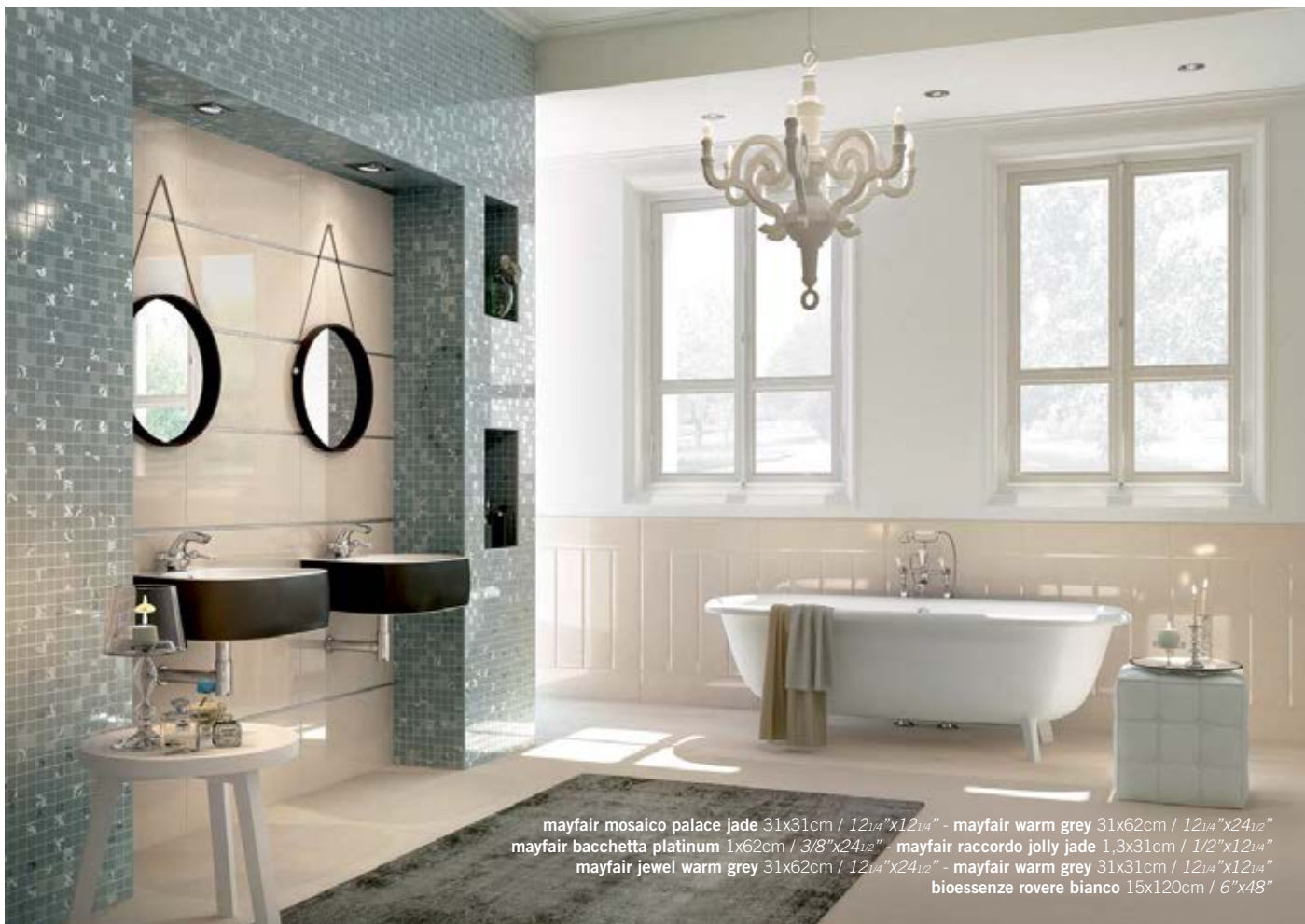

Mayfair formati e colori

sizes and colors / formats et couleurs / formaten und farben / formatos y colores

palace



DECORO PALACE
extra white 31x62cm / 12 1/4"x24 1/2" (spessore 10mm) LBVMYF6 0545



DECORO PALACE LUX
extra white 31x62cm / 12 1/4"x24 1/2" (spessore 10mm) LBVMYP6 0935



MOSAICO PALACE
extra white
31x31cm / 12 1/4"x12 1/4" LB9MYM6 0585



FASCIA PALACE
extra white
6x31cm / 2 3/8"x12 1/4" LB9MYF6 0125



BACCHETTA PALACE
extra white 2,5x62cm / 1"x12 1/4" LB9MYB6 0125

extra white

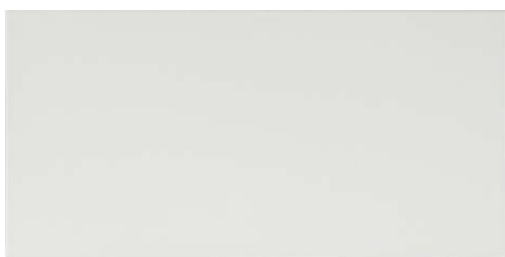

extra white
31x62cm / 12 1/4"x24 1/2" (spessore 10mm) LBAKS60 0885

style



DECORO STYLE
extra white 15x62cm / 6"x24 1/2" (spessore 13mm) LB1MYS6 0545



DECORO STYLE LUX
extra white 15x62cm / 6"x24 1/2" (spessore 13mm) LB1MYF6 0585



MOSAICO STYLE
extra white
31x31cm / 12 1/4"x12 1/4" LB9MYC6 0545

bacchette



BACCHETTA SILVER
extra white
2,5x31cm / 1"x12 1/4" LB9MYL6 0095



BACCHETTA PLATINUM
1x62cm / 3/8"x24 1/2" LB9MYBP 0325



BACCHETTA GOLD
extra white 2,5x62cm / 1"x12 1/4" LB9MYG6 0285

BEAK
extra white
1,3x1,3cm / 1/2"x1/2" LPZKS6B 0310

RACCORDO JOLLY
extra white
1,3x31cm / 1/2"x12 1/4" LPZKS6R 0220



JEWEL
extra white 31x62cm / 12 1/4"x24 1/2" (spessore 13mm) LBAKS6J 1175



extra white
31x31cm / 12 1/4"x12 1/4" LGPKS60 0725
(spessore 7,8mm)

palace



DECORO PALACE
ivory 31x62cm / 12^{1/4}"x24^{1/2}" (spessore 10mm) **LBVMYF4 0545**



DECORO PALACE LUX
ivory 31x62cm / 12^{1/4}"x24^{1/2}" (spessore 10mm) **LBVMYP4 0935**



MOSAICO PALACE
ivory
31x31cm / 12^{1/4}"x12^{1/4}" **LB9MYM4 0585**

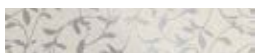

FASCIA PALACE
ivory
6x31cm / 2^{3/8}"x12^{1/4}" **LB9MYF4 0125**



BACCHETTA PALACE
ivory 2,5x62cm / 1"x12^{1/4}" **LB9MYB4 0125**

ivory

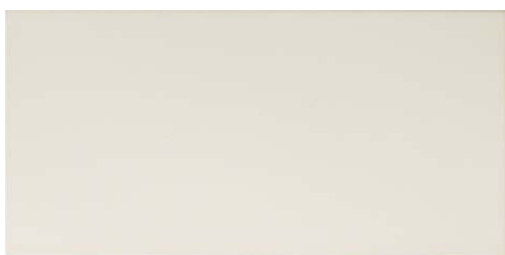

ivory
31x62cm / 12^{1/4}"x24^{1/2}" (spessore 10mm) **LBAKS40 0885**

style

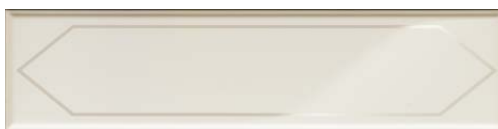

DECORO STYLE
ivory 15x62cm / 6"x24^{1/2}" (spessore 13mm) **LB1MYS4 0545**



DECORO STYLE LUX
ivory 15x62cm / 6"x24^{1/2}" (spessore 13mm) **LB1MYF4 0585**



MOSAICO STYLE
ivory
31x31cm / 12^{1/4}"x12^{1/4}" **LB9MYC4 0545**

bacchette



BACCHETTA SILVER
ivory
2,5x31cm / 1"x12^{1/4}" **LB9MYL4 0095**



BACCHETTA PLATINUM
1x62cm / 3/8"x24^{1/2}" **LB9MYBP 0325**



BACCHETTA GOLD
ivory 2,5x62cm / 1"x12^{1/4}" **LB9MYG4 0285**

BEAK
ivory
1,3x1,3cm / 1/2"x1/2" **LPZKS4B 0310**

RACCORDO JOLLY
ivory
1,3x31cm / 1/2"x12^{1/4}" **LPZKS4R 0220**



JEWEL
ivory 31x62cm / 12^{1/4}"x24^{1/2}" (spessore 13mm) **LBAKS4J 1175**



ivory
31x31cm / 12^{1/4}"x12^{1/4}" (spessore 7,8mm) **LGPKS40 0725**

Mayfair formati e colori

sizes and colors / formats et couleurs / formaten und farben / formatos y colores

palace



DECORO PALACE
warm grey 31x62cm / 12 1/4"x24 1/2" (spessore 10mm) LBVMYF3 0545



MOSAICO PALACE
warm grey
31x31cm / 12 1/4"x12 1/4" LB9MYM3 0585

style



DECORO STYLE
warm grey 15x62cm / 6"x24 1/2" (spessore 13mm) LB1MYS3 0545



DECORO STYLE LUX
warm grey 15x62cm / 6"x24 1/2" (spessore 13mm) LB1MYF3 0585



MOSAICO STYLE
warm grey
31x31cm / 12 1/4"x12 1/4" LB9MYC3 0545

bacchette



BACCHETTA SILVER
warm grey
2,5x31cm / 1"x12 1/4" LB9MYL3 0095



BACCHETTA PLATINUM
1x62cm / 3/8"x24 1/2" LB9MYBP 0325



BACCHETTA GOLD
warm grey 2,5x62cm / 1"x24 1/2" LB9MYG3 0285



FASCIA PALACE
warm grey
6x31cm / 2 3/8"x12 1/4" LB9MYF3 0125



BACCHETTA PALACE
warm grey 2,5x62cm / 1"x24 1/2" LB9MYB3 0125

warm grey

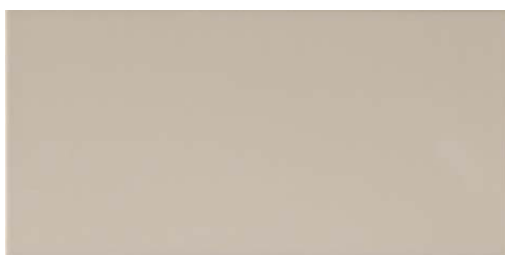

warm grey
31x62cm / 12 1/4"x24 1/2" (spessore 10mm) LBAKS30 0885



JEWEL
warm grey 31x62cm / 12 1/4"x24 1/2" (spessore 13mm) LBAKSJ3 1175

BEAK
warm grey
1,3x1,3cm / 1/2"x1/2" LPZKS3B 0310

RACCORDO JOLLY
warm grey
1,3x31cm / 1/2"x12 1/4" LPZKS3R 0220



warm grey
31x31cm / 12 1/4"x12 1/4" LGPKS30 0725
(spessore 7,8mm)

palace



DECORO PALACE
jade 31x62cm / 12^{1/4}"x24^{1/2}" (spessore 10mm) **LBVMYFO 0545**

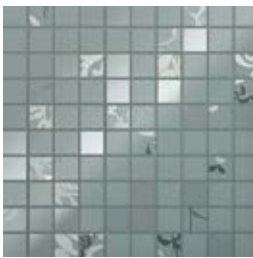

MOSAICO PALACE
jade
31x31cm / 12^{1/4}"x12^{1/4}" **LB9MYM0 0585**



FASCIA PALACE
jade
6x31cm / 2^{3/8}"x12^{1/4}" **LB9MYFO 0125**



BACCHETTA PALACE
jade 2,5x62cm / 1"x24^{1/2}" **LB9MYB0 0125**

jade

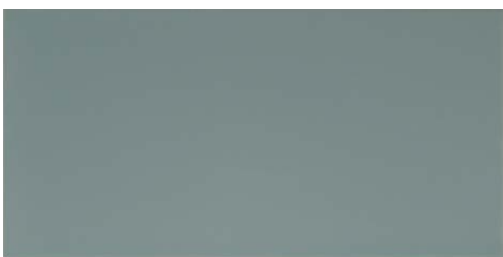

jade
31x62cm / 12^{1/4}"x24^{1/2}" (spessore 10mm) **LBAKS00 0885**

style



DECORO STYLE
jade 15x62cm / 6"x24^{1/2}" (spessore 13mm) **LBIMYSO 0545**



DECORO STYLE LUX
jade 15x62cm / 6"x24^{1/2}" (spessore 13mm) **LBIMYFO 0585**

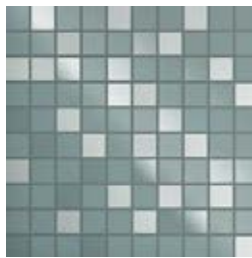

MOSAICO STYLE
jade
31x31cm / 12^{1/4}"x12^{1/4}" **LB9MYCO 0545**

bacchette



BACCHETTA SILVER
jade
2,5x31cm / 1"x12^{1/4}" **LB9MYL0 0095**



BACCHETTA PLATINUM
1x62cm / 3/8"x24^{1/2}" **LB9MYBP 0325**



BACCHETTA GOLD
jade 2,5x62cm / 1"x24^{1/2}" **LB9MYG0 0285**

BEAK
jade
1,3x1,3cm / 1/2"x1/2" **LPZKS0B 0310**

RACCORDO JOLLY
jade
1,3x31cm / 1/2"x12^{1/4}" **LPZKS0R 0220**



JEWEL
jade 31x62cm / 12^{1/4}"x24^{1/2}" (spessore 13mm) **LBAKS0J 1175**



jade
31x31cm / 12^{1/4}"x12^{1/4}" (spessore 7,8mm) **LGPKS00 0725**

KALOS

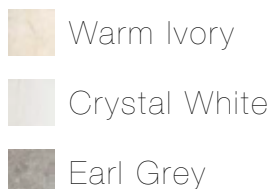

35x100cm/13³/₄"x39"



35x35cm/13³/₄"x13³/₄"

Imballi pag. 429

Packing
Emballage
Verpackung
Embalajes

MONOPOROSA IN PASTA BIANCA SMALTATA GL

Glazed white-body porous single-fired tiles
Monocuissons en pâte blanche émaillé
Weißscherbige monoporosa
Monoporosa de pasta blanca esmaltada GL

SPESSORE

Thickness
Epaisseur
Stärke
Espesor

12 mm (rivestimento 35x100)
9 mm (pavimento 35x35)

STONALIZZAZIONE

Shading
Denuançage
Spielfarbig
Grado de tonalización

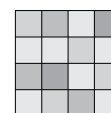

V3

FUGA MINIMA CONSIGLIATA

Minimum grout joint recommended
Joint minimum conseillé
Empfohlene Minimalfugenbreit
Distancia recomendada entre las baldosas

1 mm

RESISTENZA ALL'ABRASIONE SUPERFICIALE ISO 10545-7

Resistance to superficial abrasion
Résistance à l'abrasion superficielle
Oberflächliche reibungsbeständigkeit
Resistencia a la abrasión superficial

pei 4 (35x35)

RETTIFICATO MONOCALIBRO

Single caliber rectified
Monocalibre rectifié
Monokaliber rectifiziert
Rectificado monocálbre

ONLY 35x35 GRES SMALTATO GL

Glazed stoneware
Grès émaillé
Glasiertes Feisteinzeug
Gres esmaltado



kalos strip warm ivory 35x100cm / 13^{3/4}"x39" - **kalos warm ivory** 35x35cm / 13^{3/4}"x13^{3/4}"
kalos listello warm ivory 7x35cm / 2^{3/4}"x13^{3/4}" - **kalos lesena warm ivory** 17,5x100cm / 6^{7/8}"x39"
kalos battiscopa warm ivory 12,5x35cm / 5"x13^{3/4}" - **kalos chair rail warm ivory** 4x35cm / 1^{9/16}"x13^{3/4}"
kalos ang. chair rail warm ivory 2,5x4cm / 1"x1^{9/16}" - **kalos liner warm ivory** 1,5x35cm / 5/8"x13^{3/4}"
kalos ang. liner warm ivory 1,5x2cm / 5/8"x3/4" - **kalos raccordo jolly warm ivory** 1,5x35cm / 5/8"x13^{3/4}"



kalos warm ivory 35x100cm / 13^{3/4}"x39" - kalos strip warm ivory 35x100cm / 13^{3/4}"x39"
 kalos warm ivory 35x35cm / 13^{3/4}"x13^{3/4}" - kalos listello warm ivory 7x35cm / 2^{3/4}"x13^{3/4}"
 kalos lesena warm ivory 17,5x100cm / 6^{7/8}"x39" - kalos battiscopa warm ivory 12,5x35cm / 5"x13^{3/4}"
 kalos chair rail warm ivory 4x35cm / 1^{9/16}"x13^{3/4}"



kalos crystal white 35x100cm / 13^{3/4}"x39" - kalos ramage crystal white 35x100cm / 13^{3/4}"x39"
 kalos crystal white 35x35cm / 13^{3/4}"x13^{3/4}"

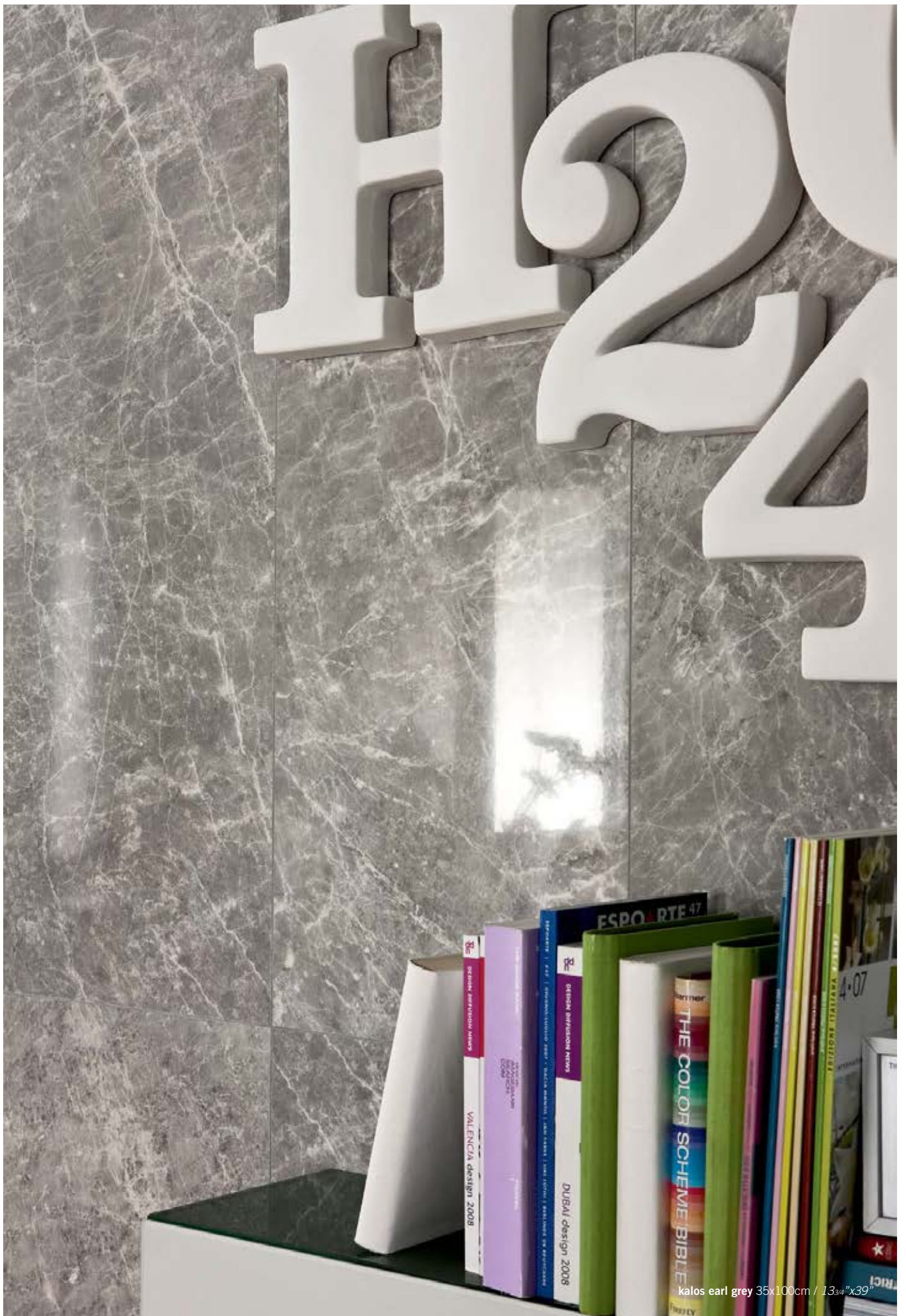

kalos earl grey 35x100cm / 13^{3/4}"x39"

Kalos formati e colori

sizes and colors / formats et couleurs / formaten und farben / formatos y colores

warm ivory



35x100cm / 13^{3/4}"x39"
rett. LFPKL10 1480

crystal white



35x100cm / 13^{3/4}"x39"
rett. LFPKL00 1480

earl grey



35x100cm / 13^{3/4}"x39"
rett. LFPKL20 1480



35x35cm / 13^{3/4}"x13^{3/4}"
rett. LGPKL10 1210



35x35cm / 13^{3/4}"x13^{3/4}"
rett. LGPKL00 1210



35x35cm / 13^{3/4}"x13^{3/4}"
rett. LGPKL20 1210

Kalos corredi

decors / articles / dekore / decorados



RAMAGE
warm ivory
35x100cm / 13³/₄"x39"
LPFKL15

1770



RAMAGE
crystal white
35x100cm / 13³/₄"x39"
LPFKL05

1770



STRIP
warm ivory
35x100cm / 13³/₄"x39"
LPFKL16

1770



STRIP
crystal white
35x100cm / 13³/₄"x39"
LPFKL06

1770

Kalos corredi e pezzi speciali

trims and decors / articles et pièces spéciales

formstücke und dekore / decorados y piezas especiales



LESENA
warm ivory
17,5x100cm / 6^{7/8}"x39"
LB9KL10 1770



LESENA
crystal white
17,5x100cm / 6^{7/8}"x39"
LB9KL00 1770



LISTELLO
warm ivory
7x35cm / 2^{3/4}"x13^{3/4}" LPZKL1L 0340



LISTELLO
crystal white
7x35cm / 2^{3/4}"x13^{3/4}" LPZKL0L 0340



CHAIR RAIL
4x35cm / 1^{9/16}"x13^{3/4}"
warm ivory LPZKL1C 0340



CHAIR RAIL
4x35cm / 1^{9/16}"x13^{3/4}"
crystal white LPZKLOC 0340



ANGOLO CHAIR RAIL
2,5x4cm / 1" x 1^{9/16}"
warm ivory LPZKL11 0490
crystal white LPZKL01 0490



BATTISCOPA
warm ivory
12,5x35cm / 5"x13^{3/4}" LG9KL10 0360



BATTISCOPA
crystal white
12,5x35cm / 5"x13^{3/4}" LG9KL00 0360



ANGOLO BATTISCOPA
2,5x12cm / 1" x 4^{3/4}"
warm ivory LG9KL11 0600
crystal white LG9KL01 0600



ANG. LISTELLO
warm ivory
7x2cm / 2^{3/4}"x3/4"
LPZKL12 0490



ANG. LISTELLO
crystal white
7x2cm / 2^{3/4}"x3/4"
LPZKL02 0490



LINER
1,5x35cm / 5/8"x13^{3/4}"
warm ivory LPZKL1E 0220
crystal white LPZKLOE 0220



ANGOLO LINER
1,5x2cm / 5/8"x3/4"
warm ivory LPZKL1A 0490
crystal white LPZKLOA 0490



RACCORDO JOLLY
warm ivory
1,5x35cm / 5/8"x13^{3/4}" LPZKL1R 0220



RACCORDO JOLLY
crystal white
1,5x35cm / 5/8"x13^{3/4}" LPZKL0R 0220



BEAK
1,2x1,5cm / 1/2"x5/8"
warm ivory LPZKL13 0310
crystal white LPZKLO3 0310



kalos earl grey 35x100cm / 13^{3/4}"x39" - **bioessenze rovere bianco** 15x120cm / 6"x48"



kalos ramage crystal white 35x100cm / 13^{3/4}"x39" - **kalos chair rail crystal white** 4x35cm / 1^{9/16}"x13^{3/4}"

ATHENA

 Onice Chiaro

 Travertino

 Pulpis



35x100cm/13^{3/4}"x39"



35x35cm/13^{3/4}"x13^{3/4}"

Imballi pag. 426

Packing
Emballage
Verpackung
Embalajes

MONOPOROSA IN PASTA BIANCA SMALTATA GL

Glazed white-body porous single-fired tiles
Monocuissons en pâte blanche émaillé
Weißscherbige monoporosa
Monoporosa de pasta blanca esmaltada GL

FUGA MINIMA CONSIGLIATA

Minimum grout joint recommended
Joint minimum conseillé
Empfohlene Minimalfugenbreit
Distancia recomendada entre las baldosas

1 mm

RESISTENZA ALL'ABRASIONE SUPERFICIALE ISO 10545-7

Resistance to superficial abrasion
Résistance à l'abrasion superficielle
Oberflächliche reibungsbeständigkeit
Resistencia a la abrasión superficial

pei 4 (35x35)

SPESSORE

Thickness
Epaisseur
Stärke
Espesor

12 mm (rivestimento 35x100)
9 mm (pavimento 35x35)

STONALIZZAZIONE

Shading
Denuançage
Spielfarbig
Grado de tonalización

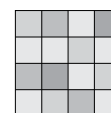

V3

RETTIFICATO MONOCALIBRO

Single caliber rectified
Monocalibre rectifié
Monokaliber rectifiziert
Rectificado monoclibre

ONLY 35x35 GRES SMALTATO GL

Glazed stoneware
Grès émaillé
Glasiertes Feinsteinzeug
Gres esmaltado



athena travertino 35x100cm / 13³/₄"x39" - athena greca travertino 10x35cm / 4"x13³/₄"
athena travertino 35x35cm / 13³/₄"x13³/₄"



athena onice chiaro 35x100cm / 13^{3/4}"x39" - **athena onice chiaro** 35x35cm / 13^{3/4}"x13^{3/4}"
athena onice chiaro decoro aster 35x100cm / 13^{3/4}"x39" - **athena battiscopa chiaro** 12x35cm / 4^{3/4}"x13^{3/4}"
athena chair rail chiaro 5,5x35cm / 2^{1/8}"x13^{3/4}"



athena mosaico mix 35x35cm / 13^{3/4}"x13^{3/4}"



athena travertino 35x100cm / 13^{3/4}"x39" - **athena decoro rhombos** 35x100cm / 13^{3/4}"x39"
athena travertino 35x35cm / 13^{3/4}"x13^{3/4}"



athena pulpis 35x100cm / 13^{3/4}"x39" - **athena decoro ithys** 35x100cm / 13^{3/4}"x39"
athena pulpis 35x35cm / 13^{3/4}"x13^{3/4}" - **athena travertino** 35x35cm / 13^{3/4}"x13^{3/4}"

Athena formati e colori

sizes and colors / formats et couleurs / formaten und farben / formatos y colores

onice chiaro



35x100cm / 13^{3/4}"x39"
rett. LPFAH00 1480

travertino



35x100cm / 13^{3/4}"x39"
rett. LPFAH20 1480

pulpis



35x100cm / 13^{3/4}"x39"
rett. LPFAH10 1480



35x35cm / 13^{3/4}"x13^{3/4}"
lapp. rett. LGPAH00 1210



35x35cm / 13^{3/4}"x13^{3/4}"
lapp. rett. LGPAH20 1210



35x35cm / 13^{3/4}"x13^{3/4}"
lapp. rett. LGPAH10 1210

Athena corredi e pezzi speciali

trims and decors / articles et pièces spéciales

formstücke und dekore / decorados y piezas especiales



DECORO ASTER
onice chiaro
35x100cm / 13³/₄"x39"
LG9AH00

1770



DECORO RHOMBOS
travertino
35x100cm / 13³/₄"x39"
LG9AH02

1770



DECORO ITHYS
pulpis
35x100cm / 13³/₄"x39"
LG9AH01

1770

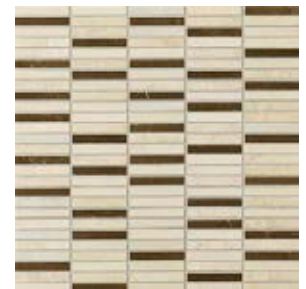

MOSAICO MIX
35x35cm / 13³/₄"x13³/₄"
LG9AH05

1070



DECORO GRECA
onice (onice-pulpis)
10x35cm / 4"x13³/₄"
LG9AH06

0680



CHAIR RAIL
chiaro
5,5x35cm / 2¹/₈"x13³/₄"
chiaro
scuro

LG9AH15 0340
LG9AH17 0340



BATTISCOPA
chiaro
12x35cm / 4³/₄"x13³/₄"
chiaro
scuro

LG9AH20 0360
LG9AH22 0360

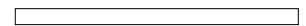

LINER
2x35cm / 3/4"x3³/₄"
chiaro
scuro

LG9AH10 0150
LG9AH12 0150



DECORO GRECA
travertino (travertino-pulpis)
10x35cm / 4"x13³/₄"
LG9AH08

0680



ANGOLO CHAIR RAIL
5,5x3,5cm / 2¹/₈"x1³/₈"
chiaro
scuro

LG9AH16 0490
LG9AH18 0490



ANGOLO BATTISCOPA
2,5x12cm / 1"x4³/₄"
chiaro
scuro

LG9AH23 0540
LG9AH21 0540



ANGOLO LINER
2x2cm / 3/4"x3/4"
chiaro
scuro

LG9AH11 0360
LG9AH13 0360



DECORO GRECA
pulpis (pulpis-travertino)
10x35cm / 4"x13³/₄"
LG9AH07

0680

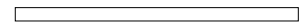

RACCORDO JOLLY
1,5x33,3cm / 5/8"x13³/₈"
onice
travertino
pulpis









LG9AH25 0220
LG9AH26 0220
LG9AH27 0220



BEAK
1,5x1,5cm / 5/8"x5/8"
onice
travertino
pulpis

LG9AH30 0310
LG9AH31 0310
LG9AH32 0310

PLEASURES

-  Lilla
-  Lilla Chiaro
-  Salvia Chiaro
-  Azzurro Chiaro
-  Sabbia Chiaro
-  Tortora
-  Bianco
-  Nero



35x35cm/13^{3/4}"x13^{3/4}"

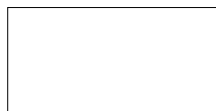

35x70cm/13^{3/4}"x27^{1/2}"

Imballi pag. 432

Packing
Emballage
Verpackung
Embalajes

MONOPOROSA IN PASTA BIANCA SMALTATA GL

Glazed white-body porous single-fired tiles
Monocuissons en pâte blanche émaillé
Weißscherbige monoporosa
Monoporosa de pasta blanca esmaltada GL

FUGA MINIMA CONSIGLIATA

Minimum grout joint recommended
Joint minimum conseillé
Empfohlene Minimalfugenbreit
Distancia recomendada entre las baldosas
1 mm

RESISTENZA ALL'ABRASIONE SUPERFICIALE ISO 10545-7

Resistance to superficial abrasion
Résistance à l'abrasion superficielle
Oberflächliche reibungsbeständigkeit
Resistencia a la abrasión superficial
pei 4 (35x35)

SPESSORE

Thickness
Epaisseur
Stärke
Espesor
10,8 mm (rivestimento 35x70)
9 mm (pavimento 35x35)

STONALIZZAZIONE

Shading
Denuançage
Spielfarbig
Grado de tonalización

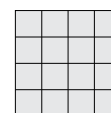

V1

RETTIFICATO MONOCALIBRO

Single caliber rectified
Monocalibre rectifié
Monokaliber rectifiziert
Rectificado monoclibre

ONLY 35x35 GRES SMALTATO GL

Glazed stoneware
Grès émaillé
Glasiertes Feinsteinzeug
Gres esmaltado



pleasures tortora 35x70cm / 133.4"x27.12"



pleasures lilla chiaro 35x70cm / 13^{3/4}"x27^{1/2}" - pleasures lilla 35x35cm / 13^{3/4}"x13^{3/4}"
pleasures lilla decoro juicy 35x70cm / 13^{3/4}"x27^{1/2}"

Pleasures formati e colori

sizes and colors / formats et couleurs / formaten und farben / formatos y colores

sabbia chiaro

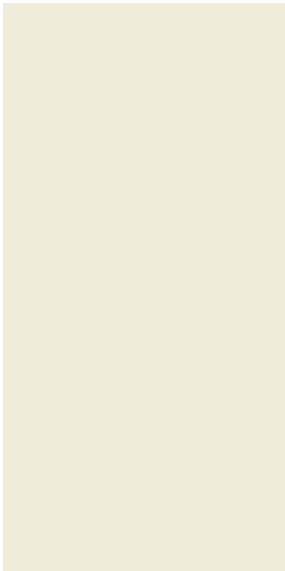

sabbia chiaro
35x70cm / 13^{3/4}"x27^{1/2}"
nat. rett. LBAP2H0 1020

tortora

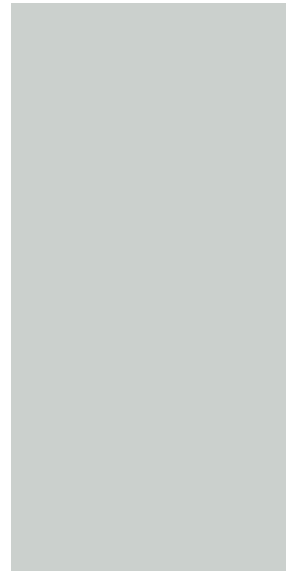

tortora
35x70cm / 13^{3/4}"x27^{1/2}"
nat. rett. LBAP2I0 1020



DECORO JUICY*
sabbia juicy b
35x70cm / 13^{3/4}"x27^{1/2}" LB9P2G3 0820



DECORO JUICY*
sabbia juicy a
35x70cm / 13^{3/4}"x27^{1/2}" LB9P2G3 0820



DECORO JUICY*
tortora juicy b
35x70cm / 13^{3/4}"x27^{1/2}" LB9P2I3 0820



DECORO JUICY*
tortora juicy a
35x70cm / 13^{3/4}"x27^{1/2}" LB9P2I3 0820

*la scatola contiene 2 pezzi A e 2 pezzi B - the box contains 2 pieces A and 2 pieces B - la boîte contient 2 pièces A et 2 pièces B - karton inhalt: 2 stück A + 2 stück B
en la caja hay 2 piezas A y 2 piezas B

Pleasures formati e colori

sizes and colors / formats et couleurs / formaten und farben / formatos y colores

azzurro chiaro

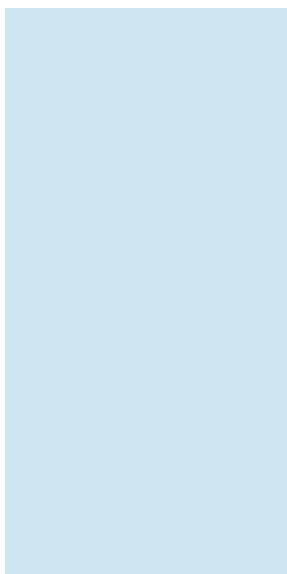

azzurro chiaro
35x70cm / 13^{3/4}"x27^{1/2}"
nat. rett. LBAP2F0 1020

salvia chiaro

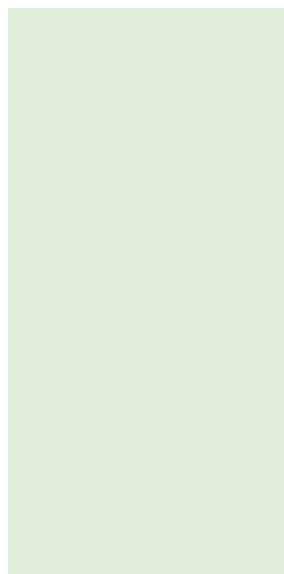

salvia chiaro
35x70cm / 13^{3/4}"x27^{1/2}"
nat. rett. LBAP2D0 1020



DECORO JUICY*
azzurro juicy b
35x70cm / 13^{3/4}"x27^{1/2}" LB9P2E3 0820



DECORO JUICY*
azzurro juicy a
35x70cm / 13^{3/4}"x27^{1/2}" LB9P2E3 0820



DECORO JUICY*
salvia juicy b
35x70cm / 13^{3/4}"x27^{1/2}" LB9P2C3 0820



DECORO JUICY*
salvia juicy a
35x70cm / 13^{3/4}"x27^{1/2}" LB9P2C3 0820

*la scatola contiene 2 pezzi A e 2 pezzi B - the box contains 2 pieces A and 2 pieces B - la boîte contient 2 pièces A et 2 pièces B - karton inhalt: 2 stück A + 2 stück B
en la caja hay 2 piezas A y 2 piezas B

lilla

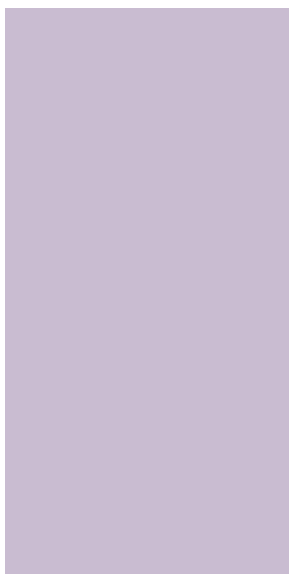

lilla
35x70cm / 13^{3/4}"x27^{1/2}"
nat. rett. **LBAP2A0 1020**

bianco

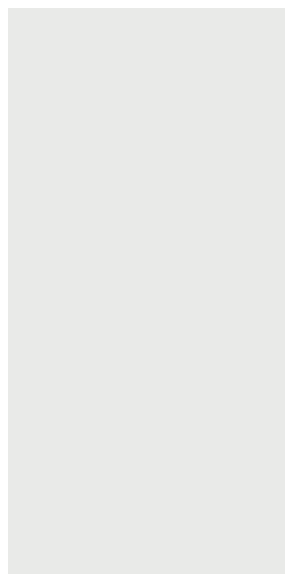

bianco
35x70cm / 13^{3/4}"x27^{1/2}"
nat. rett. **LBAP2P0 1020**

nero

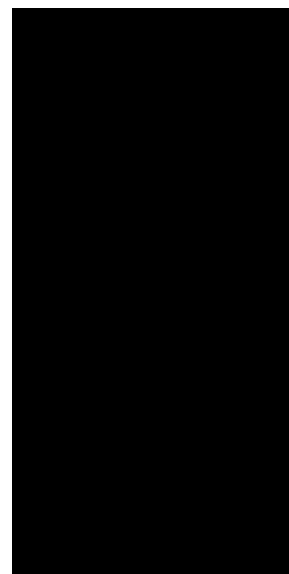

nero
35x70cm / 13^{3/4}"x27^{1/2}"
nat. rett. **LBAP2R0 1020**



DECORO JUICY*
lilla juicy a
35x70cm / 13^{3/4}"x27^{1/2}" **LB9P2A3 0820**



DECORO JUICY*
lilla juicy b
35x70cm / 13^{3/4}"x27^{1/2}" **LB9P2A3 0820**

Pleasures corredi e pezzi speciali

trims and decors / articles et pièces spéciales

formstücke und dekore / decorados y piezas especiales

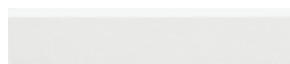

CHAIR RAIL
bianco 7x35cm / 2 3/4"x13 3/4"
LB9P2PC **0340**

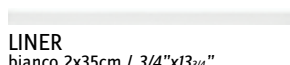

LINER
bianco 2x35cm / 3/4"x13 3/4"
LB9P2PB **0150**



RACCORDO JOLLY
bianco 2x35cm / 3/4"x13 3/4"
LB9P2PD **0220**

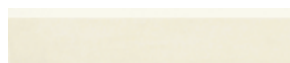

CHAIR RAIL
sabbia chiaro 7x35cm / 2 3/4"x13 3/4"
LB9P2HC **0340**

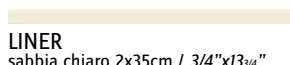

LINER
sabbia chiaro 2x35cm / 3/4"x13 3/4"
LB9P2HB **0150**

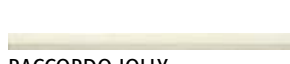

RACCORDO JOLLY
sabbia chiaro 2x35cm / 3/4"x13 3/4"
LB9P2HD **0220**



CHAIR RAIL
azzurro 7x35cm / 2 3/4"x13 3/4"
LB9P2FC **0340**

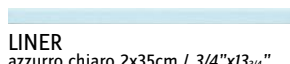

LINER
azzurro chiaro 2x35cm / 3/4"x13 3/4"
LB9P2FB **0150**

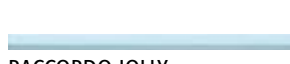

RACCORDO JOLLY
azzurro chiaro 2x35cm / 3/4"x13 3/4"
LB9P2FD **0220**



CHAIR RAIL
lilla 7x35cm / 2 3/4"x13 3/4"
LB9P2AC **0340**

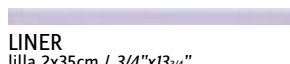

LINER
lilla 2x35cm / 3/4"x13 3/4"
LB9P2AB **0150**



RACCORDO JOLLY
lilla 2x35cm / 3/4"x13 3/4"
LB9P2AD **0220**



ANG. CHAIR RAIL
bianco 2x7cm / 3/4"x2 3/4"
LB9P2PE **0490**



ANG. LINER
bianco 2x2cm / 3/4"x3/4"
LB9P2PF **0360**



BEAK
bianco 2x2cm / 3/4"x3/4"
LB9P2PA **0310**



ANG. CHAIR RAIL
sabbia ch. 2x7cm / 3/4"x2 3/4"
LB9P2HE **0490**



ANG. LINER
sabbia ch. 2x2cm / 3/4"x3/4"
LB9P2HF **0360**



BEAK
sabbia ch. 2x2cm / 3/4"x3/4"
LB9P2HA **0310**



ANG. CHAIR RAIL
azzurro ch. 2x7cm / 3/4"x2 3/4"
LB9P2FE **0490**



ANG. LINER
azzurro ch. 2x2cm / 3/4"x3/4"
LB9P2FF **0360**



BEAK
azzurro ch. 2x2cm / 3/4"x3/4"
LB9P2FA **0310**



ANG. CHAIR RAIL
lilla 2x7cm / 3/4"x2 3/4"
LB9P2AE **0490**



ANG. LINER
lilla 2x2cm / 3/4"x3/4"
LB9P2AF **0360**



BEAK
lilla 2x2cm / 3/4"x3/4"
LB9P2AA **0310**



CHAIR RAIL
nero 7x35cm / 2 3/4"x13 3/4"
LB9P2RC **0340**

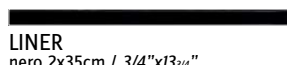

LINER
nero 2x35cm / 3/4"x13 3/4"
LB9P2RB **0150**

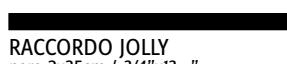

RACCORDO JOLLY
nero 2x35cm / 3/4"x13 3/4"
LB9P2RD **0220**



CHAIR RAIL
tortora 7x35cm / 2 3/4"x13 3/4"
LB9P2IC **0340**

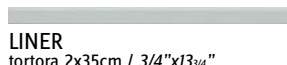

LINER
tortora 2x35cm / 3/4"x13 3/4"
LB9P2IB **0150**



RACCORDO JOLLY
tortora 2x35cm / 3/4"x13 3/4"
LB9P2ID **0220**



CHAIR RAIL
salvia chiaro 7x35cm / 2 3/4"x13 3/4"
LB9P2DC **0340**

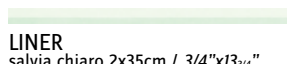

LINER
salvia chiaro 2x35cm / 3/4"x13 3/4"
LB9P2DB **0150**



RACCORDO JOLLY
salvia chiaro 2x35cm / 3/4"x13 3/4"
LB9P2DD **0220**



CHAIR RAIL
lilla chiaro 7x35cm / 2 3/4"x13 3/4"
LB9P2BC **0340**

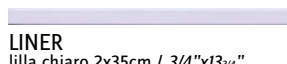

LINER
lilla chiaro 2x35cm / 3/4"x13 3/4"
LB9P2BB **0150**

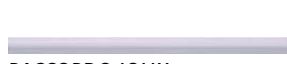

RACCORDO JOLLY
lilla chiaro 2x35cm / 3/4"x13 3/4"
LB9P2BD **0220**



ANG. CHAIR RAIL
nero 2x7cm / 3/4"x2 3/4"
LB9P2RE **0490**



ANG. LINER
nero 2x2cm / 3/4"x3/4"
LB9P2RF **0360**



BEAK
nero 2x2cm / 3/4"x3/4"
LB9P2RA **0310**



ANG. CHAIR RAIL
tortora 2x7cm / 3/4"x2 3/4"
LB9P2IE **0490**



ANG. LINER
tortora 2x2cm / 3/4"x3/4"
LB9P2IF **0360**



BEAK
tortora 2x2cm / 3/4"x3/4"
LB9P2IA **0310**



ANG. CHAIR RAIL
salvia ch. 2x7cm / 3/4"x2 3/4"
LB9P2DE **0490**



ANG. LINER
salvia ch. 2x2cm / 3/4"x3/4"
LB9P2DF **0360**



BEAK
salvia ch. 2x2cm / 3/4"x3/4"
LB9P2DA **0310**



ANG. CHAIR RAIL
lilla ch. 2x7cm / 3/4"x2 3/4"
LB9P2BE **0490**



ANG. LINER
lilla ch. 2x2cm / 3/4"x3/4"
LB9P2bF **0360**



BEAK
lilla ch. 2x2cm / 3/4"x3/4"
LB9P2bA **0310**

Pavimenti coordinati

Coordinated floors / Sols coordonnés

Passende Boden / Pavimentos combiados

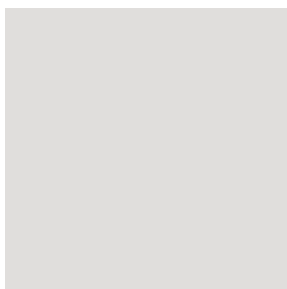

bianco
35x35cm / 13^{3/4}"x13^{3/4}"
matt rett. LGPP2P0 0950

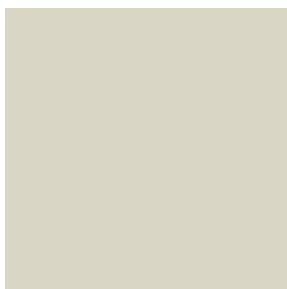

sabbia
35x35cm / 13^{3/4}"x13^{3/4}"
matt rett. LGPP2G0 0950



tortora
35x35cm / 13^{3/4}"x13^{3/4}"
matt rett. LGPP2I0 0950

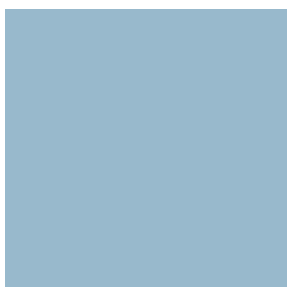

azzurro
35x35cm / 13^{3/4}"x13^{3/4}"
matt rett. LGPP2E0 0950



salvia
35x35cm / 13^{3/4}"x13^{3/4}"
matt rett. LGPP2C0 0950





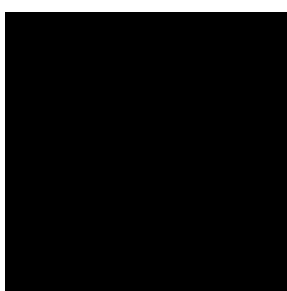



lilla
35x35cm / 13^{3/4}"x13^{3/4}"
matt rett. LGPP2A0 0950



nero
35x35cm / 13^{3/4}"x13^{3/4}"
matt rett. LGPP2R0 0950

AUDREY

-  Lilla
-  Salvia Chiaro
-  Azzurro Chiaro
-  Sabbia Chiaro
-  Tortora
-  Bianco
-  Nero



35x35cm / 13^{3/4}" x 13^{3/4}"



35x70cm / 13^{3/4}" x 27^{1/2}"

Imballi pag. 426

Packing
Emballage
Verpackung
Embalajes

MONOPOROSA IN PASTA BIANCA SMALTATA GL

Glazed white-body porous single-fired tiles
Monocuissons en pâte blanche émaillé
Weißscherbige monoporosa
Monoporosa de pasta blanca esmaltada GL

FUGA MINIMA CONSIGLIATA

Minimum grout joint recommended
Joint minimum conseillé
Empfohlene Minimalfugenbreit
Distancia recomendada entre las baldosas
1 mm

RESISTENZA ALL'ABRASIONE SUPERFICIALE ISO 10545-7

Resistance to superficial abrasion
Résistance à l'abrasion superficielle
Oberflächliche reibungsbeständigkeit
Resistencia a la abrasión superficial
pei 4 (35x35)

SPESSORE

Thickness
Epaisseur
Stärke
Espesor
10,8 mm (rivestimento 35x70)
9 mm (pavimento 35x35)

STONALIZZAZIONE

Shading
Denuançage
Spielfarbig
Grado de tonalización

RETTIFICATO MONOCALIBRO

Single caliber rectified
Monocalibre rectifié
Monokaliber rectifiziert
Rectificado monoclibre

ONLY 35x35 GRES SMALTATO GL

Glazed stoneware
Grès émaillé
Glasiertes Feinsteinzeug
Gres esmaltado

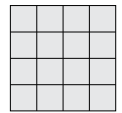

V1
(fondi Pleasures)

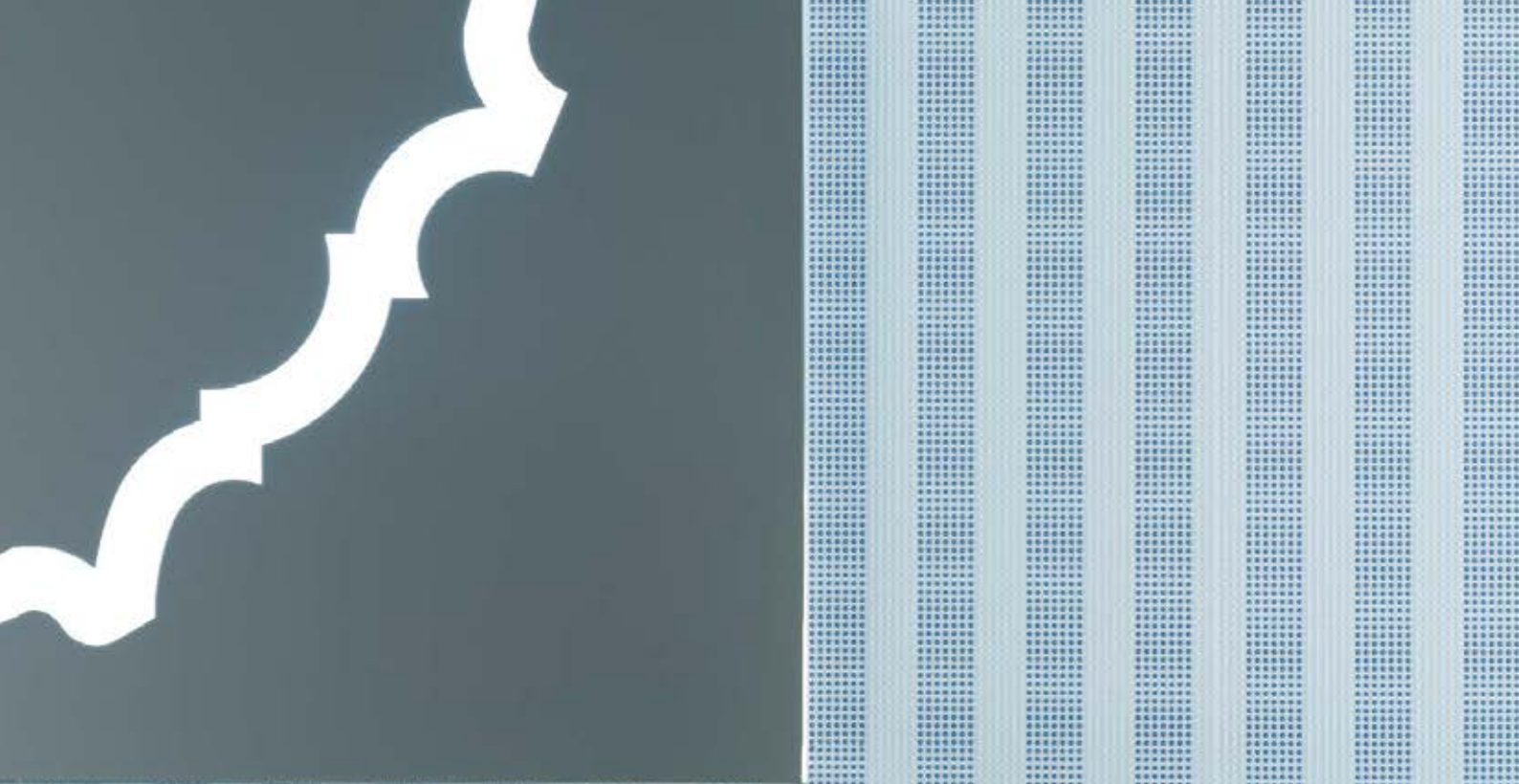

audrey stripes azzurro chiaro 35x70cm / 134"x27 1/2"





audrey galles sabbia chiaro 35x70cm / 13^{3/4}"x27^{1/2}" - audrey sabbia 35x35cm / 13^{3/4}"x13^{3/4}"

Audrey formati e colori

sizes and colors / formats et couleurs / formaten und farben / formatos y colores

bianco

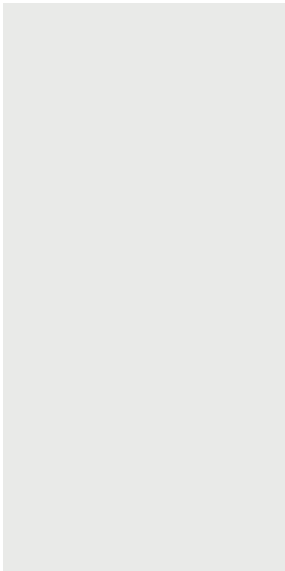

bianco
35x70cm / 13^{3/4}"x27^{1/2}"
nat. rett. LBAP2P0 1020



nero
35x70cm / 13^{3/4}"x27^{1/2}"
nat. rett. LBAP2R0 1020



ANG. LINER
antracite 2x2cm / 3/4"x3/4"
LB9A24A 0360

LINER

antracite 2x35cm / 3/4"x13^{3/4}"
LB9A24L 0150

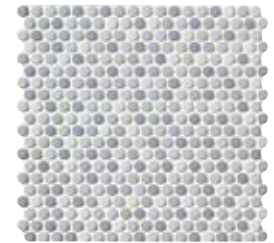

MENTINE
mentine tortora
30x32cm / 12"x12^{1/2}" LB9A214 0735

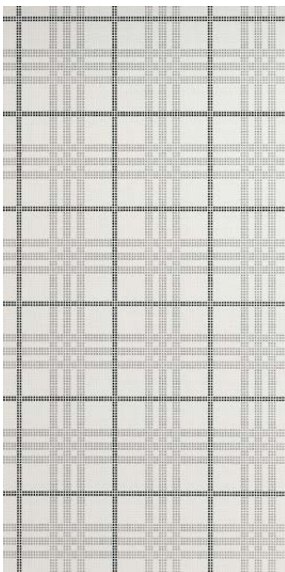

DECORO GALLES
galles bianco
35x70cm / 13^{3/4}"x27^{1/2}" LB9A2P3 1015



DECORO BLOSSOMS
blossoms bianco
35x70cm / 13^{3/4}"x27^{1/2}" LB9A2P1 1015

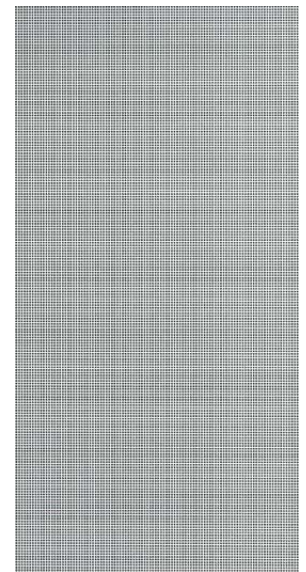

DECORO DOTS
dots bianco
35x70cm / 13^{3/4}"x27^{1/2}" LB9A2P0 1015

sabbia chiaro

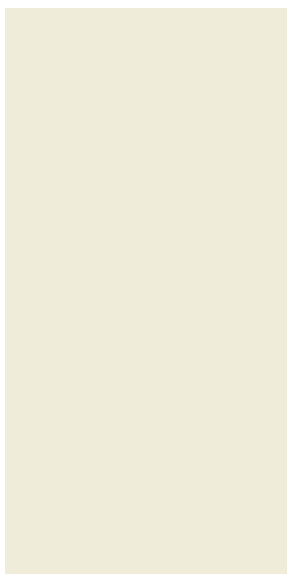

sabbia chiaro
35x70cm / 13^{3/4}"x27^{1/2}"
nat. rett. LBAP2H0 1020



ANG. LINER
fango 2x2cm / 3/4"x3/4"
LB9A20A

0360

LINER
fango 2x35cm / 3/4"x13^{3/4}"
LB9A20L

0150



MENTINE
mentine sabbia
30x32cm / 12"x12^{1/2}" LB9A2G4 0735

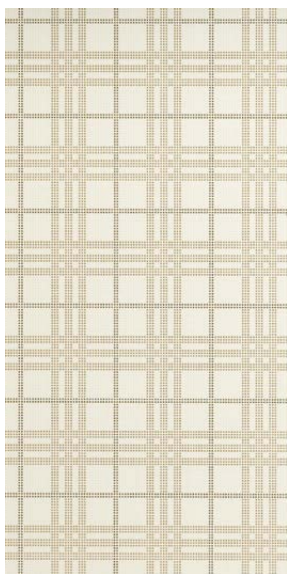

DECORO GALLES
galles sabbia chiaro
35x70cm / 13^{3/4}"x27^{1/2}" LB9A2H3 1015



DECORO BLOSSOMS
blossoms sabbia chiaro
35x70cm / 13^{3/4}"x27^{1/2}" LB9A2H1 1015



DECORO DOTS
dots sabbia chiaro
35x70cm / 13^{3/4}"x27^{1/2}" LB9A2H0 1015

Audrey formati e colori

sizes and colors / formats et couleurs / formaten und farben / formatos y colores

tortora

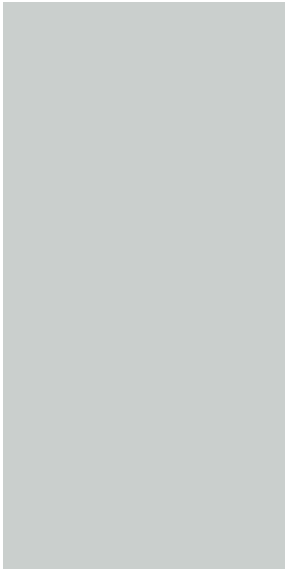

tortora
35x70cm / 13^{3/4}"x27^{1/2}"
nat. rett. LBAP210 1020



ANG. LINER
antracite 2x2cm / 3/4"x3/4"
LB9A24A 0360

LINER
antracite 2x35cm / 3/4"x13^{3/4}"
LB9A24L 0150

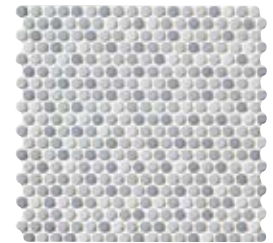

MENTINE
mentine tortora
30x32cm / 12"x12^{1/2}" LB9A214 0735

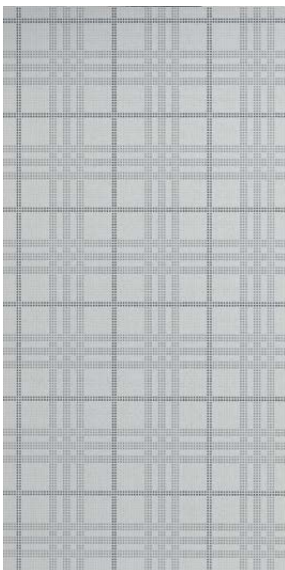

DECORO GALLES
galles tortora
35x70cm / 13^{3/4}"x27^{1/2}" LB9A213 1015



DECORO BLOSSOMS
blossoms tortora
35x70cm / 13^{3/4}"x27^{1/2}" LB9A211 1015

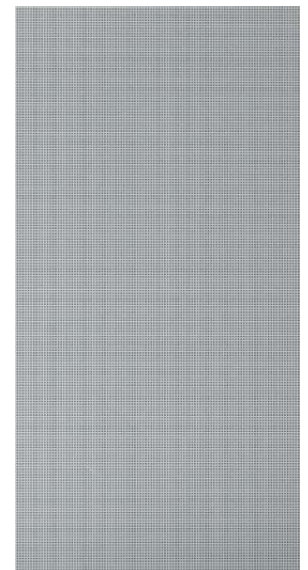

DECORO DOTS
dots tortora
35x70cm / 13^{3/4}"x27^{1/2}" LB9A210 1015

azzurro chiaro

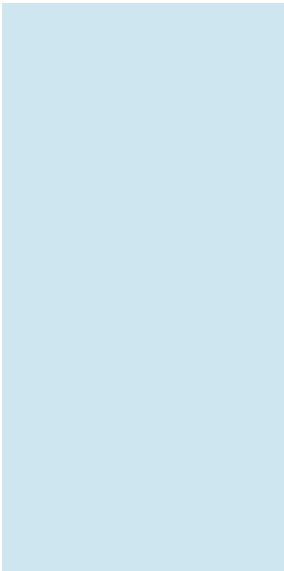

azzurro chiaro
35x70cm / 13^{3/4}"x27^{1/2}"
nat. rett. LBAP2F0 1020



ANG. LINER
blu 2x2cm / 3/4"x3/4"
LB9A22A

0360

LINER
blu 2x35cm / 3/4"x13^{3/4}"
LB9A22L

0150

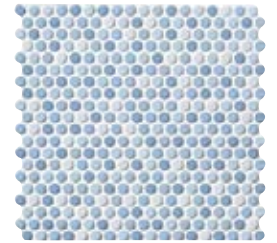

MENTINE
mentine azzurro
30x32cm / 12"x12^{1/2}" L B9A2E4 0735

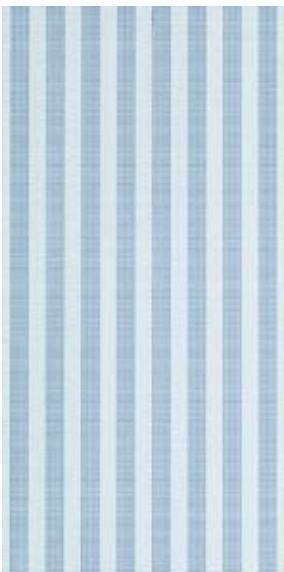

DECORO STRIPES
stripes azzurro chiaro
35x70cm / 13^{3/4}"x27^{1/2}" LB9A2F2 1015



DECORO BLOSSOMS
blossoms azzurro chiaro
35x70cm / 13^{3/4}"x27^{1/2}" LB9A2F1 1015



DECORO DOTS
dots azzurro chiaro
35x70cm / 13^{3/4}"x27^{1/2}" LB9A2F0 1015

Audrey formati e colori

sizes and colors / formats et couleurs / formaten und farben / formatos y colores

salvia chiaro

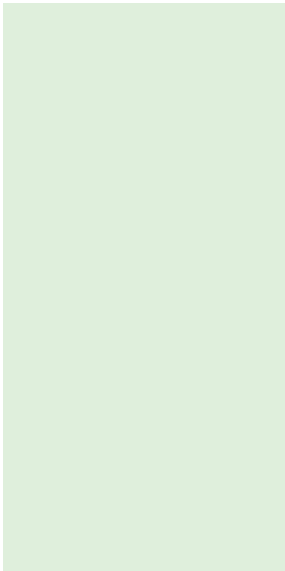

salvia chiaro
35x70cm / 13^{3/4}"x27^{1/2}"
nat. rett. LBAP2D0 1020



ANG. LINER
verde 2x2cm / 3/4"x3/4"
LB9A21A 0360

LINER

verde 2x35cm / 3/4"x13^{3/4}"
LB9A21L 0150

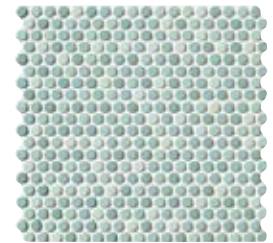

MENTINE
mentine salvia
30x32cm / 12"x12^{1/2}" LB9A2C4 0735

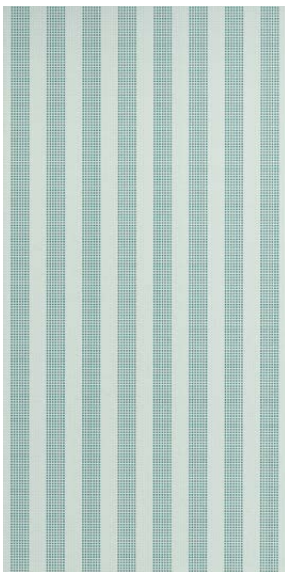

DECORO STRIPES
stripes salvia chiaro
35x70cm / 13^{3/4}"x27^{1/2}" LB9A2D2 1015

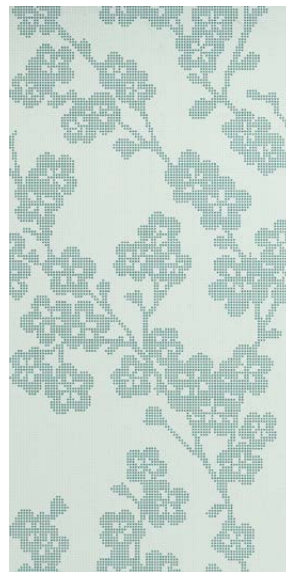

DECORO BLOSSOMS
blossoms salvia chiaro
35x70cm / 13^{3/4}"x27^{1/2}" LB9A2D1 1015

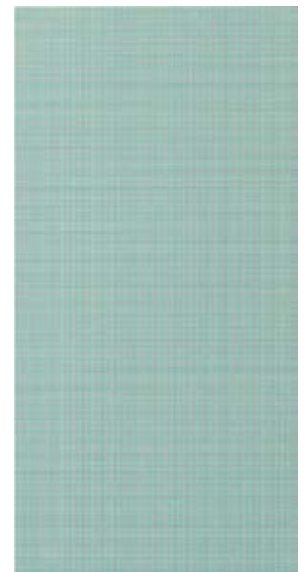

DECORO DOTS
dots salvia chiaro
35x70cm / 13^{3/4}"x27^{1/2}" LB9A2D0 1015

lilla

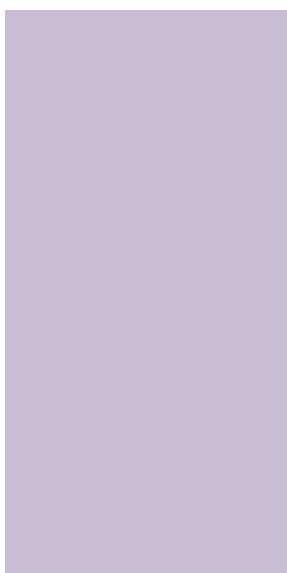

lilla
35x70cm / 13^{3/4}"x27^{1/2}"
nat. rett. LBAP2A0 1020



ANG. LINER
viola 2x2cm / 3/4"x3/4"
LB9A23A

0360

LINER
viola 2x35cm / 3/4"x13^{3/4}"
LB9A23L

0150

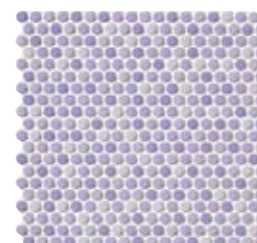

MENTINE
mentine lilla
30x32cm / 12"x12^{1/2}" LB9A2A4 0735

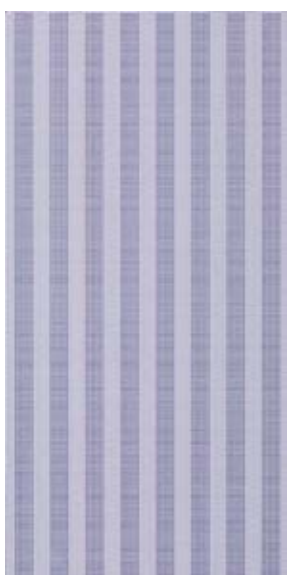

DECORO STRIPES
stripes lilla
35x70cm / 13^{3/4}"x27^{1/2}" LB9A2A2 1015



DECORO BLOSSOMS
blossoms lilla
35x70cm / 13^{3/4}"x27^{1/2}" LB9A2A1 1015



DECORO DOTS
dots lilla
35x70cm / 13^{3/4}"x27^{1/2}" LB9A2A0 1015

Audrey pezzi speciali in abbinamento serie Pleasures

Audrey trims that can be matched with Pleasures / Audrey pièces spéciales s'accordant à la collection Pleasures / Audrey formstücke passend zu serie Pleasures / Audrey piezas especiales en combinación con la serie Pleasures

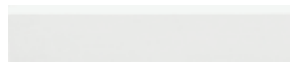

CHAIR RAIL
bianco 7x35cm / 2 3/4"x13 3/4"
LB9P2PC **0340**

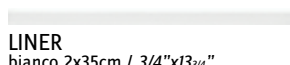

LINER
bianco 2x35cm / 3/4"x13 3/4"
LB9P2PB **0150**



RACCORDO JOLLY
bianco 2x35cm / 3/4"x13 3/4"
LB9P2PD **0220**

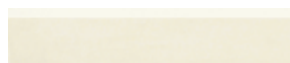

CHAIR RAIL
sabbia chiaro 7x35cm / 2 3/4"x13 3/4"
LB9P2HC **0340**

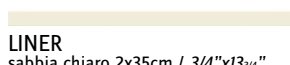

LINER
sabbia chiaro 2x35cm / 3/4"x13 3/4"
LB9P2HB **0150**

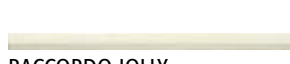

RACCORDO JOLLY
sabbia chiaro 2x35cm / 3/4"x13 3/4"
LB9P2HD **0220**



CHAIR RAIL
azzurro 7x35cm / 2 3/4"x13 3/4"
LB9P2FC **0340**

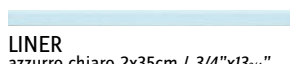

LINER
azzurro chiaro 2x35cm / 3/4"x13 3/4"
LB9P2FB **0150**



RACCORDO JOLLY
azzurro chiaro 2x35cm / 3/4"x13 3/4"
LB9P2FD **0220**



CHAIR RAIL
lilla 7x35cm / 2 3/4"x13 3/4"
LB9P2AC **0340**

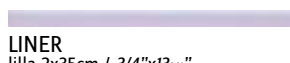

LINER
lilla 2x35cm / 3/4"x13 3/4"
LB9P2AB **0150**

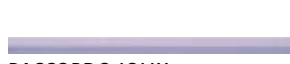

RACCORDO JOLLY
lilla 2x35cm / 3/4"x13 3/4"
LB9P2AD **0220**



ANG. CHAIR RAIL
bianco 2x7cm / 3/4"x2 3/4"
LB9P2PE **0490**



ANG. LINER
bianco 2x2cm / 3/4"x3/4"
LB9P2PF **0360**



BEAK
bianco 2x2cm / 3/4"x3/4"
LB9P2PA **0310**



ANG. CHAIR RAIL
sabbia ch. 2x7cm / 3/4"x2 3/4"
LB9P2HE **0490**



ANG. LINER
sabbia ch. 2x2cm / 3/4"x3/4"
LB9P2HF **0360**



BEAK
sabbia ch. 2x2cm / 3/4"x3/4"
LB9P2HA **0310**



ANG. CHAIR RAIL
azzurro ch. 2x7cm / 3/4"x2 3/4"
LB9P2FE **0490**



ANG. LINER
azzurro ch. 2x2cm / 3/4"x3/4"
LB9P2FF **0360**



BEAK
azzurro ch. 2x2cm / 3/4"x3/4"
LB9P2FA **0310**



ANG. CHAIR RAIL
lilla 2x7cm / 3/4"x2 3/4"
LB9P2AE **0490**



ANG. LINER
lilla 2x2cm / 3/4"x3/4"
LB9P2AF **0360**



BEAK
lilla 2x2cm / 3/4"x3/4"
LB9P2AA **0310**



CHAIR RAIL
nero 7x35cm / 2 3/4"x13 3/4"
LB9P2RC **0340**

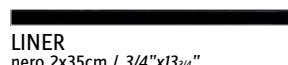

LINER
nero 2x35cm / 3/4"x13 3/4"
LB9P2RB **0150**

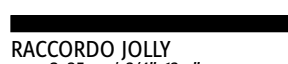

RACCORDO JOLLY
nero 2x35cm / 3/4"x13 3/4"
LB9P2RD **0220**



CHAIR RAIL
tortora 7x35cm / 2 3/4"x13 3/4"
LB9P2IC **0340**

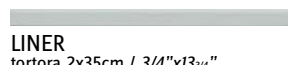

LINER
tortora 2x35cm / 3/4"x13 3/4"
LB9P2IB **0150**



RACCORDO JOLLY
tortora 2x35cm / 3/4"x13 3/4"
LB9P2ID **0220**



CHAIR RAIL
salvia chiaro 7x35cm / 2 3/4"x13 3/4"
LB9P2DC **0340**

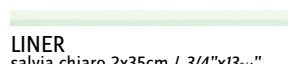

LINER
salvia chiaro 2x35cm / 3/4"x13 3/4"
LB9P2DB **0150**

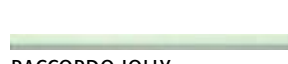

RACCORDO JOLLY
salvia chiaro 2x35cm / 3/4"x13 3/4"
LB9P2DD **0220**



ANG. CHAIR RAIL
nero 2x7cm / 3/4"x2 3/4"
LB9P2RE **0490**



ANG. LINER
nero 2x2cm / 3/4"x3/4"
LB9P2RF **0360**



BEAK
nero 2x2cm / 3/4"x3/4"
LB9P2RA **0310**



ANG. CHAIR RAIL
tortora 2x7cm / 3/4"x2 3/4"
LB9P2IE **0490**



ANG. LINER
tortora 2x2cm / 3/4"x3/4"
LB9P2IF **0360**



BEAK
tortora 2x2cm / 3/4"x3/4"
LB9P2IA **0310**



ANG. CHAIR RAIL
salvia ch. 2x7cm / 3/4"x2 3/4"
LB9P2DE **0490**



ANG. LINER
salvia ch. 2x2cm / 3/4"x3/4"
LB9P2DF **0360**



BEAK
salvia ch. 2x2cm / 3/4"x3/4"
LB9P2DA **0310**

Pavimenti coordinati

coordinated floors / sols coordonnés

passende Boden / pavimentos combiados

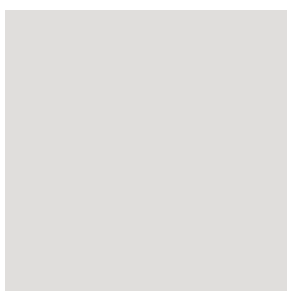

bianco
35x35cm / 13^{3/4}"x13^{3/4}"
matt rett. LGPP2P0 0950

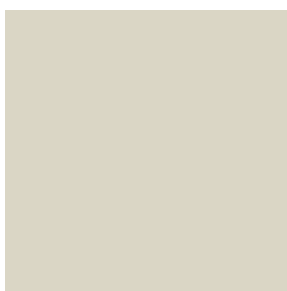

sabbia
35x35cm / 13^{3/4}"x13^{3/4}"
matt rett. LGPP2G0 0950



tortora
35x35cm / 13^{3/4}"x13^{3/4}"
matt rett. LGPP2I0 0950

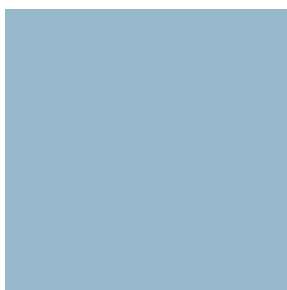

azzurro
35x35cm / 13^{3/4}"x13^{3/4}"
matt rett. LGPP2E0 0950



salvia
35x35cm / 13^{3/4}"x13^{3/4}"
matt rett. LGPP2C0 0950



lilla
35x35cm / 13^{3/4}"x13^{3/4}"
matt rett. LGPP2A0 0950

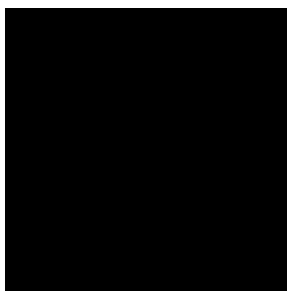

nero
35x35cm / 13^{3/4}"x13^{3/4}"
matt rett. LGPP2R0 0950

TRÈS JOLIE

-  Damier
-  Damier Blanc
-  Damier Noir
-  Petit Pois
-  Grand Pois
-  Capitonné
-  Damas Or
-  Damas Noir



35x70cm/13^{3/4}"x27^{1/2}"

***DECORO REALIZZATO CON:**
Decor made with:
Décor réalisé avec:
Das Dekor ist aus hergestellt:
Decoración realizada con:

Imballi pag. 436
Packing
Emballage
Verpackung
Embalajes

MONOPOROSA IN PASTA BIANCA SMALTATA GL

Glazed white-body porous single-fired tiles
Monocuissons en pâte blanche émaillé
Weißscherbige monoporosa
Monoporosa de pasta blanca esmaltada GL

FUGA MINIMA CONSIGLIATA

Minimum grout joint recommended
Joint minimum conseillé
Empfohlene Minimalfugenbreit
Distancia recomendada entre las baldosas
1 mm

SPESSORE

Thickness
Epaisseur
Stärke
Espesor
10,8 mm

RETTIFICATO MONOCALIBRO

Single caliber rectified
Monocalibre réctifié
Monokaliber rectifiziert
Rectificado monocalibre

très jolie damier noir 35x70cm / 13^{3/4}"x27^{1/2}" - très jolie damier blanc 35x70cm / 13^{3/4}"x27^{1/2}"
pleasures bianco 35x35cm / 13^{3/4}"x13^{3/4}"





très jolie grand pois 35x70cm / 13^{3/4}"x27^{1/2}"



très jolie damas noir 35x70cm / 13^{3/4}"x27^{1/2}"

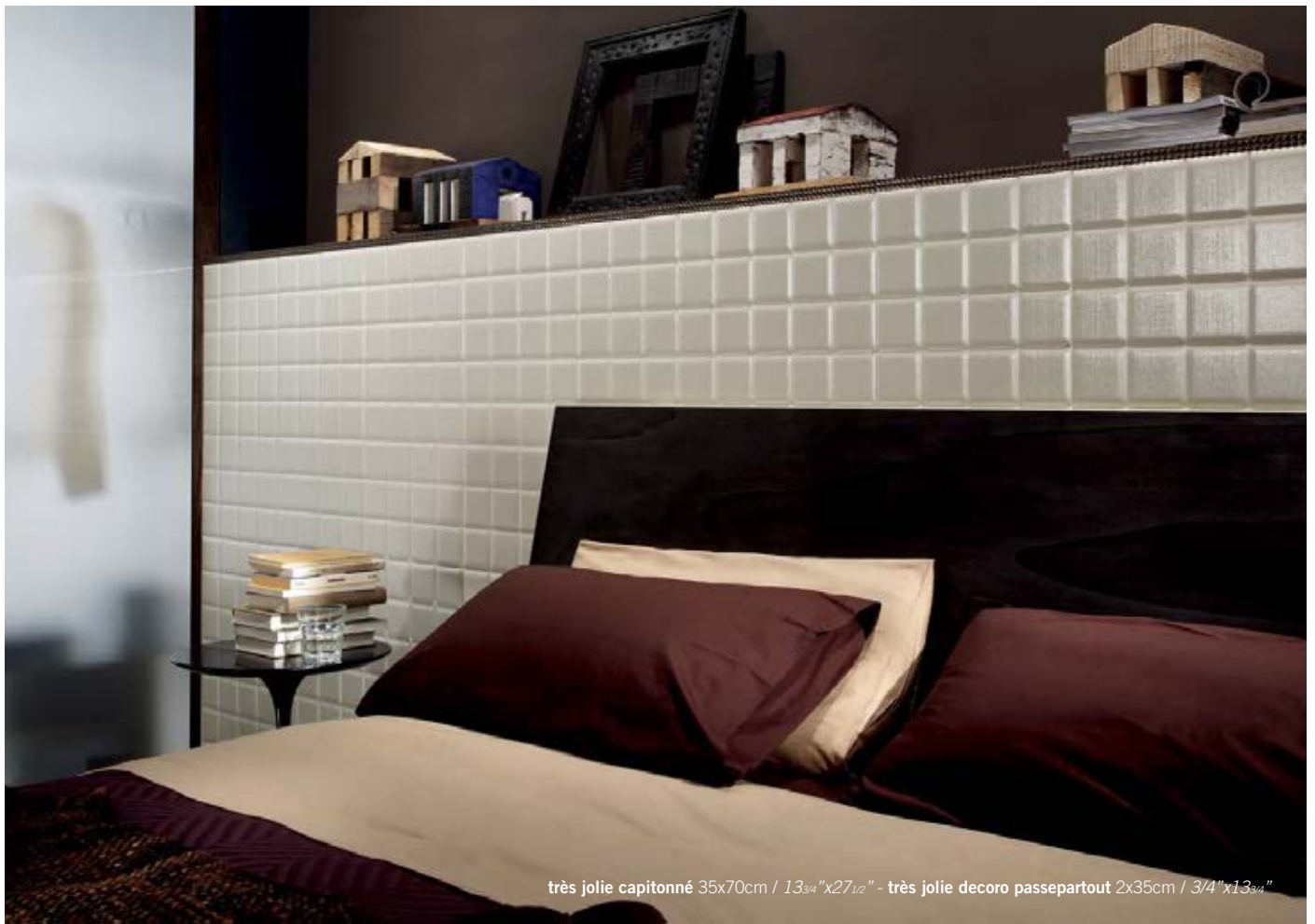

très jolie capitonné 35x70cm / 13^{3/4}"x27^{1/2}" - très jolie decoro passepartout 2x35cm / 3/4"x13^{3/4}"

Très Jolie formats e colori

sizes and colors / formats et couleurs / formaten und farben / formatos y colores

capitonné



35x70cm / 13³/₄"x27¹/₂"
LP9TJ15

1630

petit pois

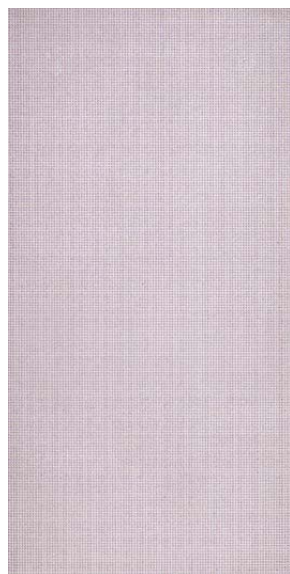

35x70cm / 13³/₄"x27¹/₂"
LP9TJ13

0840

grand pois

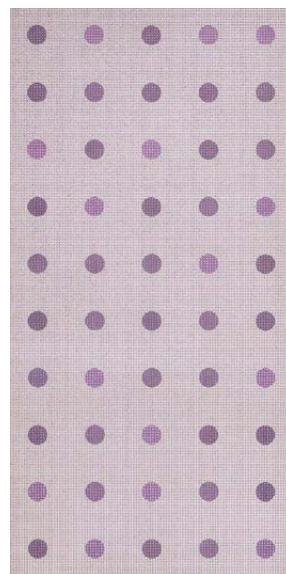

35x70cm / 13³/₄"x27¹/₂"
LP9TJ14

0840

damas or



35x70cm / 13³/₄"x27¹/₂"
LP9TJ12

1860

abbinabilità a pleasures / combinations pleasures

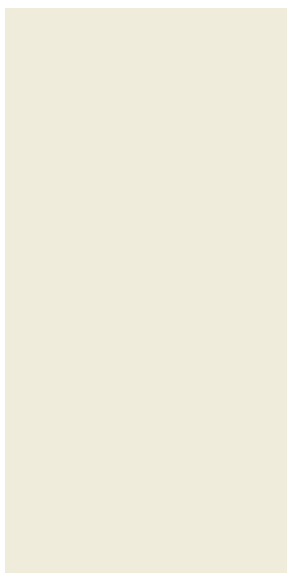

sabbia chiaro
35x70cm / 13³/₄"x27¹/₂"
nat. rett.

LBAP2H0 1020

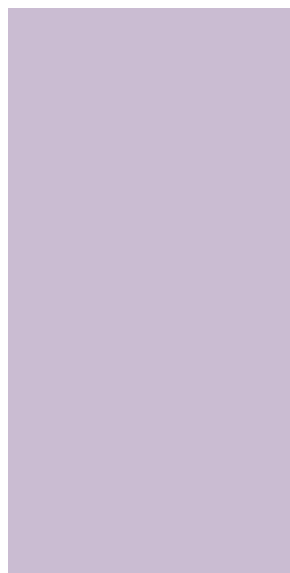

lilla
35x70cm / 13³/₄"x27¹/₂"
nat. rett.

LBAP2A0 1020

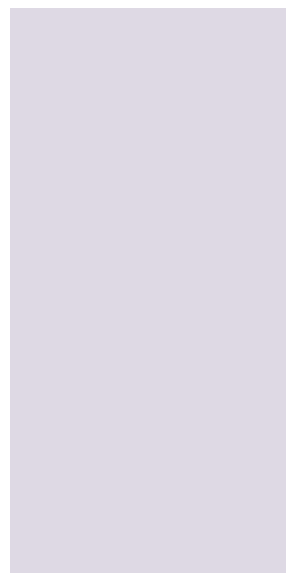

lilla chiaro
35x70cm / 13³/₄"x27¹/₂"
nat. rett.

LBAP2B0 1020

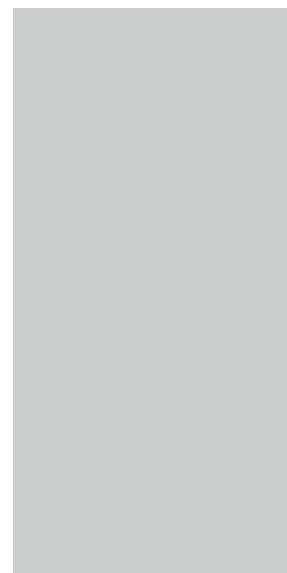

tortora
35x70cm / 13³/₄"x27¹/₂"
nat. rett.

LBAP2I0 1020

damas noir



35x70cm / 13 3/4"x27 1/2"
LP9TJ11

0840

damier blanc



35x70cm / 13 3/4"x27 1/2"
LP9TJ16

1440

damier noir

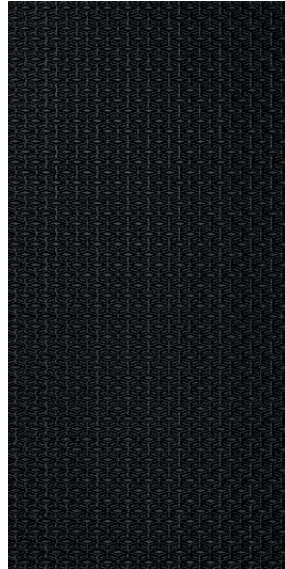

35x70cm / 13 3/4"x27 1/2"
LP9TJ17

1440

damier

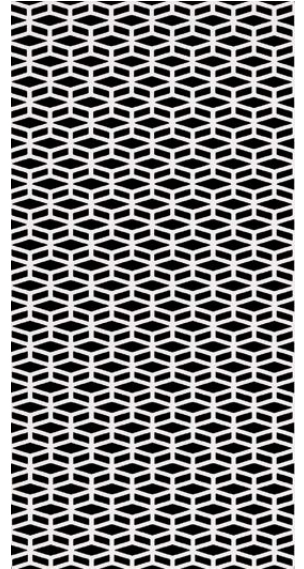

35x70cm / 13 3/4"x27 1/2"
LP9TJ10

0840

abbinabilità a pleasures / combinations pleasures

Très Jolie decori

decors / decors / dekore / decoros

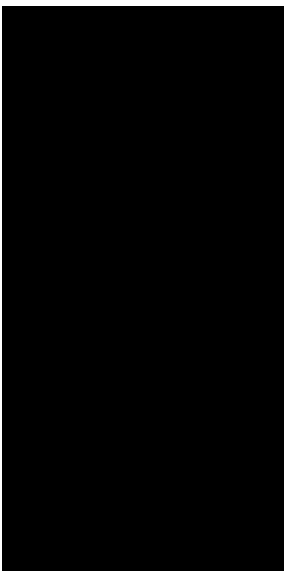

nero
35x70cm / 13 3/4"x27 1/2"
nat. rett.

LBAP2RO 1020

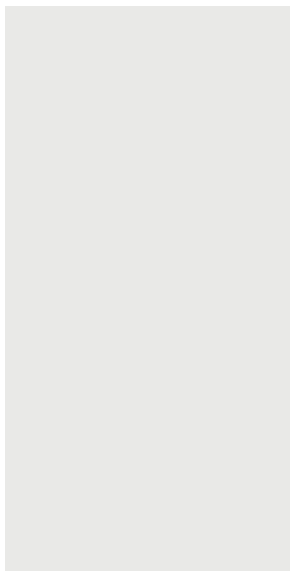

bianco
35x70cm / 13 3/4"x27 1/2"
nat. rett.

LBAP2PO 1020



DECORO PARISIENNE
listello
1,5x35cm / 5/8"x13 3/4"
LP9TJ00 0230

DECORO PARISIENNE
fascia
5x35cm / 2"x13 3/4"
LP9TJ01 0490

DECORO PASSEPARTOUT
2x35cm / 3/4"x13 3/4"
LP9TJ02 0230

PROGETTO L14

design Gianluca Soddu

 Gesso	 Mostarda	 3x40cm/13 1/8"x16"
 Nocciola	 Ginepro	 10x40cm/4"x16"
 Vaniglia	 Kiwi	 20x40cm/8"x16"
 Cemento	 Xwhite	 double 24 20x40cm/8"x16"
 Origano	 Xblack	 preinciso 20x40cm/8"x16"
 Paprika		

Imballi pag. 432

Packing
Emballage
Verpackung
Embalajes

MONOPOROSA IN PASTA BIANCA SMALTATA GL

Glazed white-body porous single-fired tiles
Monocuissons en pâte blanche émaillé
Weißscherbige monoporosa
Monoporosa de pasta blanca esmaltada GL

SPESSORE

Thickness
Epaisseur
Stärke
Espesor
9 mm

STONALIZZAZIONE

Shading
Denuançage
Spielfarbig
Grado de tonalización

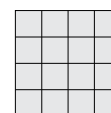

V1

FUGA MINIMA CONSIGLIATA

Minimum grout joint recommended
Joint minimum conseillé
Empfohlene Minimalfugenbreit
Distancia recomendada entre las baldosas
1 mm



progetto L14 xwhite glossy mood 24 20x40cm / 8"x16" - progetto L14 xblack glossy mood 24 20x40cm / 8"x16"
progetto L14 xwhite glossy mood 14 10x40cm / 4"x16" - progetto L14 xblack glossy mood 14 10x40cm / 4"x16"
progetto L14 xwhite glossy note 3x40cm / 1³/₁₆"x16" - progetto L14 xblack decoro spy 10x40cm / 4"x16"



progetto L14 origano glossy double 24 20x40cm / 8"x16" - progetto L14 origano decoro roads 10x40cm / 4"x16"
 progetto L14 nocciola matt mood 24 20x40cm / 8"x16"



progetto L14 vaniglia matt mood 24 20x40cm / 8"x16" - progetto L14 vaniglia matt mood 14 10x40cm / 4"x16"
 progetto L14 vaniglia decoro record 14 10x40cm / 4"x16" - progetto L14 paprika decoro spy 10x40cm / 4"x16"



progetto L14 kiwi double 24 20x40cm / 8"x16" - bioessenze noce 15x120cm / 6"x48"

Progetto L14 formati e colori

sizes and colors / formats et couleurs / formaten und farben / formatos y colores

gesso matt



mood 14
10x40cm / 4"x16"

LPDPTIO 1180

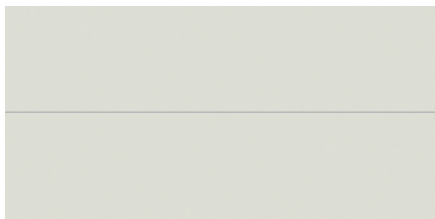

double 24
20x40cm / 8"x16"
(preinciso 10x40cm / 4"x16")

LPNPTID 0760

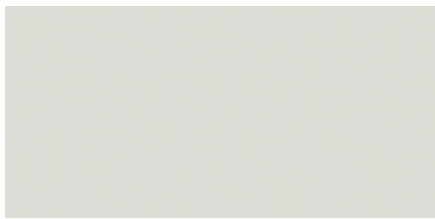

mood 24
20x40cm / 8"x16"

LPNPTIO 0730

vaniglia matt

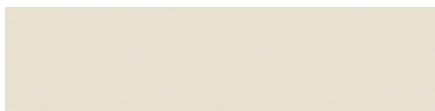

mood 14
10x40cm / 4"x16"

LPDPTCO 1180

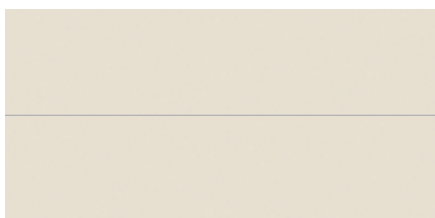

double 24
20x40cm / 8"x16"
(preinciso 10x40cm / 4"x16")

LPNPTCD 0760

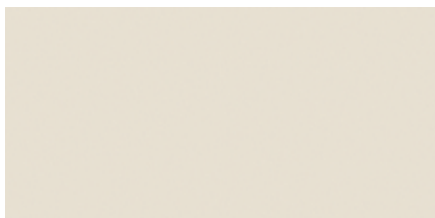

mood 24
20x40cm / 8"x16"

LPNPTCO 0730

nocciola matt



mood 14
10x40cm / 4"x16"

LPDPTBO 1180

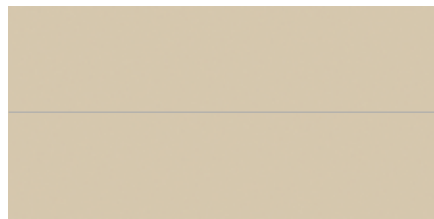

double 24
20x40cm / 8"x16"
(preinciso 10x40cm / 4"x16")

LPNPTBD 0760



mood 24
20x40cm / 8"x16"

LPNPTBO 0730

cemento matt



mood 14
10x40cm / 4"x16"

LPDPTHO 1180

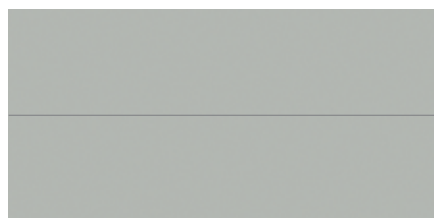

double 24
20x40cm / 8"x16"
(preinciso 10x40cm / 4"x16")

LPNPTHD 0760



mood 24
20x40cm / 8"x16"

LPNPTHO 0730

ginepro glossy



mood 14
10x40cm / 4"x16"

LPDPTQO 1180



double 24
20x40cm / 8"x16"
(preinciso 10x40cm / 4"x16")

LPNPTQD 0760

origano glossy



mood 14
10x40cm / 4"x16"

LPDPTLO 1180



double 24
20x40cm / 8"x16"
(preinciso 10x40cm / 4"x16")

LPNPTLD 0760

kiwi glossy



mood 14
10x40cm / 4"x16"

LPDPTS0 1180



double 24
20x40cm / 8"x16"
(preinciso 10x40cm / 4"x16")

LPNPTS0 0760

paprika glossy



mood 14
10x40cm / 4"x16"

LPDPTM0 1180

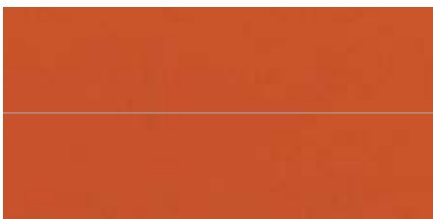

double 24
20x40cm / 8"x16"
(preinciso 10x40cm / 4"x16")

LPNPTMD 0760

mostarda glossy



mood 14
10x40cm / 4"x16"

LPDPTN0 1180



double 24
20x40cm / 8"x16"
(preinciso 10x40cm / 4"x16")

LPNPTND 0760

xwhite glossy



mood 14
10x40cm / 4"x16"

LPDPTX0 1180

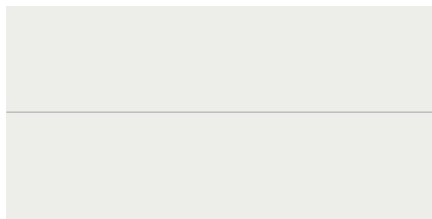

double 24
20x40cm / 8"x16"
(preinciso 10x40cm / 4"x16")

LPNPTXD 0760

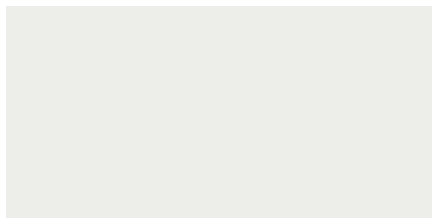

mood 24
20x40cm / 8"x16"

LPNPTX0 0730



note 24
20x40cm / 8"x16"
(preinciso 3x40cm / 1 3/16"x16")

LPNPTX7 1570

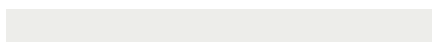

note
3x40cm / 1 3/16"x16"

LPBPTX0 0020

xblack glossy



mood 14
10x40cm / 4"x16"

LPDPTW0 1180

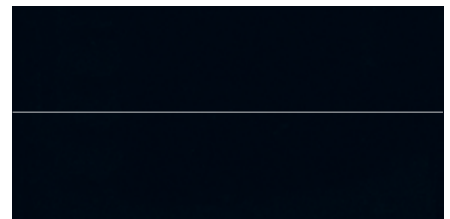

double 24
20x40cm / 8"x16"
(preinciso 10x40cm / 4"x16")

LPNPTWD 0760



mood 24
20x40cm / 8"x16"

LPNPTW0 0730

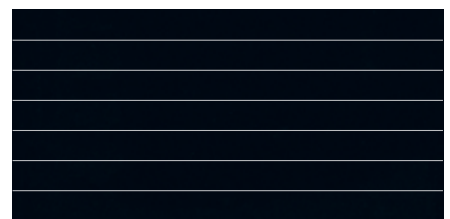

note 24
20x40cm / 8"x16"
(preinciso 3x40cm / 1 3/16"x16")

LPNPTW7 1570



note
3x40cm / 1 3/16"x16"

LPBPTW0 0020

Progetto L14 decori

decors / decors / dekore / decoros



record 14
10x40cm / 4"x16"
nocciola LPDPTB2 0320
vaniglia LPDPTC2 0320
cemento LPDPTH2 0320
gesso LPDPTI2 0320
origano LPDPTL2 0320
paprika LPDPTM2 0320
mostarda LPDPTN2 0320

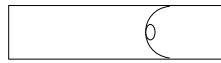

soft
10x40cm / 4"x16"
nocciola LPDPTB5 0520
vaniglia LPDPTC5 0520
cemento LPDPTH5 0520
gesso LPDPTI5 0520
origano LPDPTL5 0520
paprika LPDPTM5 0520
mostarda LPDPTN5 0520

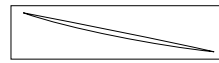

spy
10x40cm / 4"x16"
nocciola LPDPTB6 0520
vaniglia LPDPTC6 0520
cemento LPDPTH6 0520
gesso LPDPTI6 0520
origano LPDPTL6 0520
paprika LPDPTM6 0520
mostarda LPDPTN6 0520
xblack LPDPTX6 0520
xwhite LPDPTX6 0520

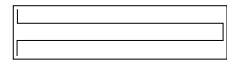

roads
10x40cm / 4"x16"
nocciola LPDPTB7 0520
vaniglia LPDPTC7 0520
cemento LPDPTH7 0520
gesso LPDPTI7 0520
origano LPDPTL7 0520
paprika LPDPTM7 0520
mostarda LPDPTN7 0520

tavola sinottica

synoptic table / tableau synoptique / übersichtstafel / tabla sinóptica

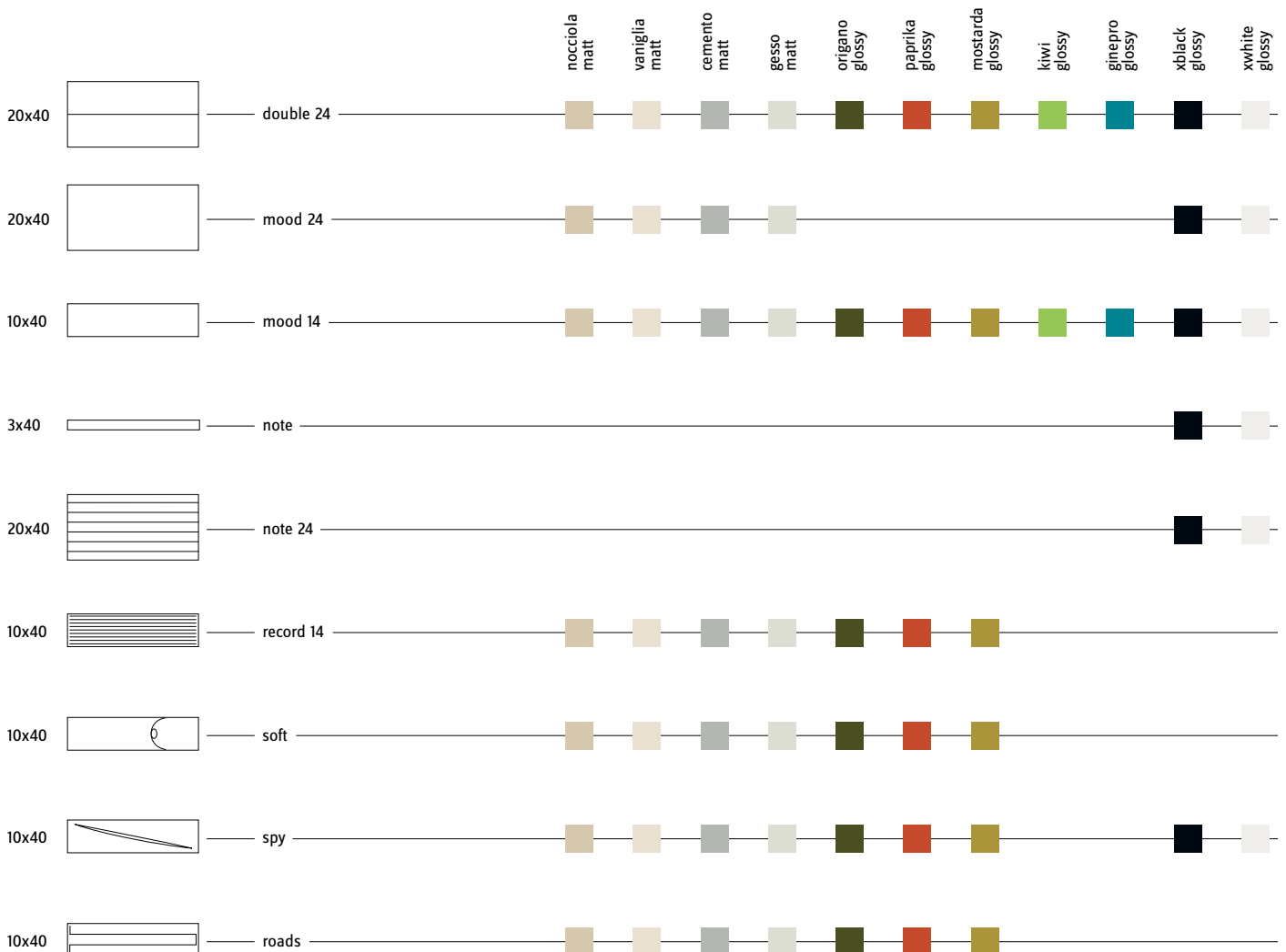



progetto L14 xblack double 24 20x40cm / 8"x16" - progetto L14 xblack decoro spy 10x40cm / 4"x16"



progetto L14 mostarda glossy decoro soft 10x40cm / 4"x16"

GOCCIA

design Kravitz Design Inc.

 White

 Black



13x13cm / 5 1/8" x 5 1/8"



10x40cm / 4" x 16"



10x40cm / 4" x 16"

***DECORO REALIZZATO CON:**
Decor made with:
Décor réalisé avec:
Das Dekor ist aus hergestellt:
Decoración realizada con:

Imballi pag. 429

Packing
Emballage
Verpackung
Embalajes

MONOPOROSA IN PASTA BIANCA SMALTATA GL

Glazed white-body porous single-fired tiles
Monocuissons en pâte blanche émaillé
Weißscherbige monoporosa
Monoporosa de pasta blanca esmaltada GL

SPESSORE

Thickness
Épaisseur
Stärke
Espesor

9 mm

STONALIZZAZIONE

Shading
Denuançage
Spielfarbig
Grado de tonalización

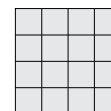

V1

FUGA MINIMA CONSIGLIATA

Minimum grout joint recommended
Joint minimum conseillé
Empfohlene Minimalfugenbreit
Distancia recomendada entre las baldosas

1 mm



goccia double tune out black glossy 10x40cm / 4"x16"



goccia single tune out white matt 10x40cm / 4"x16" - mauk slimtech esa lappata - naturale 38,3cm / 15,1/8"



goccia tune in white glossy 13x13cm / 5.1/8" x 5.1/8"
goccia tune out white glossy 13x13cm / 5.1/8" x 5.1/8"



goccia distorsion black glossy 13x13cm / 5.1/8" x 5.1/8"

Goccia formati e colori

sizes and colors / formats et couleurs / formaten und farben / formatos y colores

white

tune in

single tune in

double tune in



white glossy
13x13cm / 5 1/8" x 5 1/8"
LPIGE01 0315



white glossy
10x40cm / 4" x 16" LPDGE01 0425



white glossy
10x40cm / 4" x 16" LPDGE06 0425



white matt
13x13cm / 5 1/8" x 5 1/8"
LPIGE21 0315



white matt
10x40cm / 4" x 16" LPDGE21 0425



white matt
10x40cm / 4" x 16" LPDGE26 0425

tune out

single tune out

double tune out



white glossy
13x13cm / 5 1/8" x 5 1/8"
LPIGE00 0315



white glossy
10x40cm / 4" x 16" LPDGE00 0425



white glossy
10x40cm / 4" x 16" LPDGE05 0425



white matt
13x13cm / 5 1/8" x 5 1/8"
LPIGE20 0315



white matt
10x40cm / 4" x 16" LPDGE20 0425



white matt
10x40cm / 4" x 16" LPDGE25 0425

distorsion



white glossy
13x13cm / 5 1/8" x 5 1/8"
LPIGE0D 0315

black

tune in



black glossy
13x13cm / 5 1/8" x 5 1/8"
LPDGE11 0425

single tune in



black glossy
10x40cm / 4" x 16"
LPDGE11 0425

double tune in



black glossy
10x40cm / 4" x 16"
LPDGE16 0425



black matt
13x13cm / 5 1/8" x 5 1/8"
LPDGE31 0425



black matt
10x40cm / 4" x 16"
LPDGE31 0425



black matt
10x40cm / 4" x 16"
LPDGE36 0425

tune out



black glossy
13x13cm / 5 1/8" x 5 1/8"
LPDGE10 0425

single tune out



black glossy
10x40cm / 4" x 16"
LPDGE10 0425

double tune out



black glossy
10x40cm / 4" x 16"
LPDGE15 0425



black matt
13x13cm / 5 1/8" x 5 1/8"
LPDGE30 0425



black matt
10x40cm / 4" x 16"
LPDGE30 0425



black matt
10x40cm / 4" x 16"
LPDGE35 0425

distorsion



black glossy
13x13cm / 5 1/8" x 5 1/8"
LPDGE1D 0315

Goccia è abbinabile alla serie Progetto L14

Goccia can be matched with Progetto L14 / Goccia s'accorde à la collection Progetto L14

Goccia passend zu serie Progetto L14 / Goccia se puede combinar con la serie Progetto L14

xwhite glossy

xblack glossy

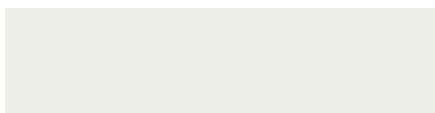

mood 14
10x40cm / 4"x16"

LPDPTX0 1180



mood 14
10x40cm / 4"x16"

LPDPTW0 1180

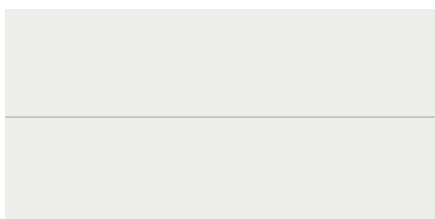

double 24
20x40cm / 8"x16"
(preinciso 10x40cm / 4"x16")

LPNPTXD 0760

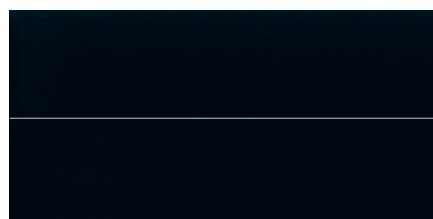

double 24
20x40cm / 8"x16"
(preinciso 10x40cm / 4"x16")

LPNPTWD 0760

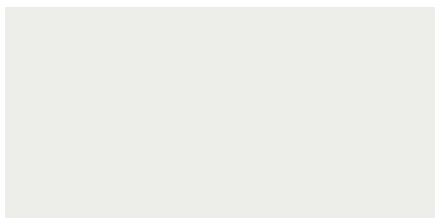

mood 24
20x40cm / 8"x16"

LPNPTX0 0730



mood 24
20x40cm / 8"x16"

LPNPTW0 0730



note 24
20x40cm / 8"x16"
(preinciso 3x40cm / 1 3/16"x16")

LPNPTX7 1570

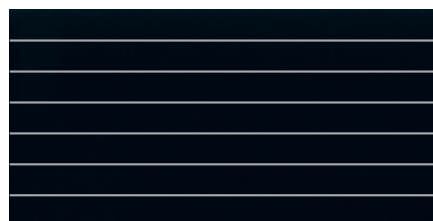

note 24
20x40cm / 8"x16"
(preinciso 3x40cm / 1 3/16"x16")

LPNPTW7 1570

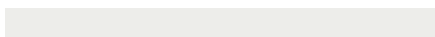

note
3x40cm / 1 3/16"x16"

LPBPTX0 0020



note
3x40cm / 1 3/16"x16"

LPBPTW0 0020

gesso matt



mood 14
10x40cm / 4"x16"

LPDPTIO 1180

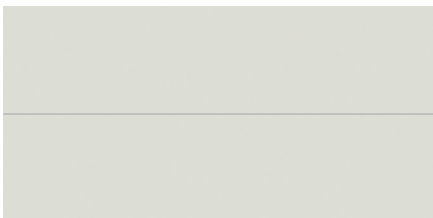

double 24
20x40cm / 8"x16"
(preinciso 10x40cm / 4"x16")

LPNPTID 0760

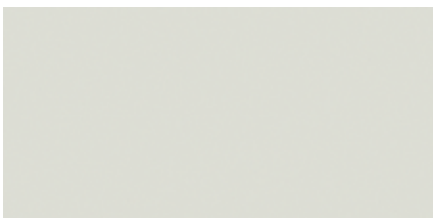

mood 24
20x40cm / 8"x16"

LPNPTIO 0730

PAILLETES

 Bianco

 Oro

 Bronzo

 Cromo

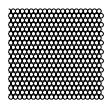

30x32cm/12"x12 1/2"

Imballi pag. 431

Packing
Emballage
Verpackung
Embalajes

MONOPOROSA IN PASTA BIANCA SMALTATA GL

Glazed white-body porous single-fired tiles
Monocuissons en pâte blanche émaillé
Weißscherbige monoporosa
Monoporosa de pasta blanca esmaltada GL

SPESSORE

Thickness
Epaisseur
Stärke
Espesor
5 mm

STONALIZZAZIONE

Shading
Denuançage
Spielfarbig
Grado de tonalización

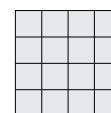

V1

FUGA MINIMA CONSIGLIATA

Minimum grout joint recommended
Joint minimum conseillé
Empfohlene Minimalfugenbreit
Distancia recomendada entre las baldosas
1 mm

RETTIFICATO MONOCALIBRO

Single caliber rectified
Monocalibre réctifié
Monokaliber rectifiziert
Rectificado monocalibre







paillettes bianco 30x32cm / 12"x12 1/2"

Paillettes formati e colori

sizes and colors / formats et couleurs / formaten und farben / formatos y colores

bianco

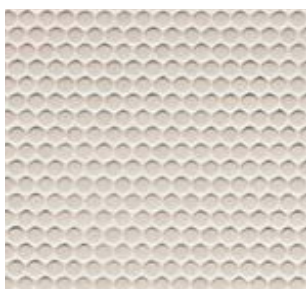

30x32cm / 12"x12 1/2"
LPPP300

2080

oro

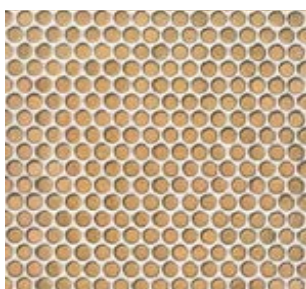

30x32cm / 12"x12 1/2"
LPPP360

2080

bronzo

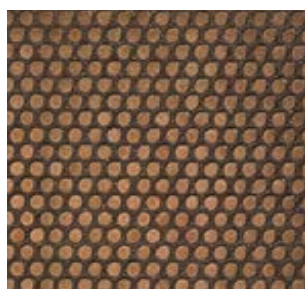

30x32cm / 12"x12 1/2"
LPPP370

2080

cromo



30x32cm / 12"x12 1/2"
LPPP380

2080

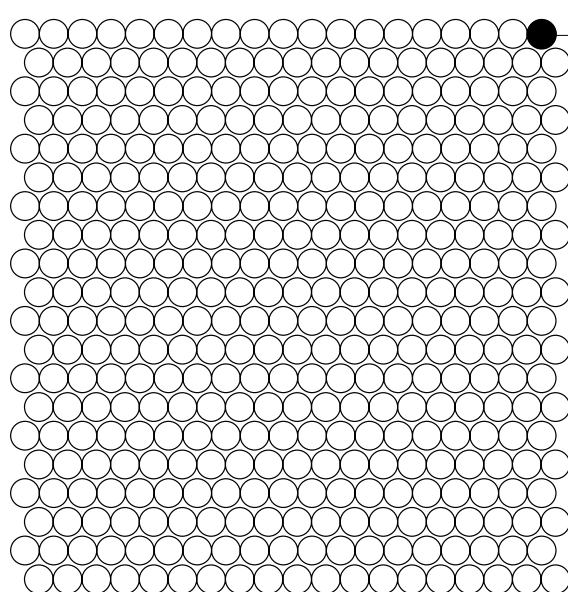

diametro

1,5cm / 5/8"

Paillettes decori

decors / decors / dekore / decoros



DECORO BANDIERA
composizione 1 pezzo
decor pattern 1 piece

LP9P302 1320



DECORO CAMELIA
composizione 4 pezzi
decor pattern 4 pieces

LP9P300 1320

STUCCHI

Lea Ceramiche consiglia di stuccare Paillettes con:

- stucco cementizio bianco (a contrasto) per tutti i colori.
- stucco epossidico (Mapei Kerapoxy Design) per i decori Bandiera e Camelia.

POSA

Lea Ceramiche consiglia di posare Paillettes su una parete perfettamente planare.

Le piastrelle Paillettes dovranno essere posate assicurandosi che la freccia presente nel retro di ogni singolo pezzo, sia rivolta verso la stessa direzione.

GROUT

Lea Ceramiche recommends using the following grouts for Paillettes :

- white cement-based grout (contrasting) for all colors.
- epoxy grout (Mapei Kerapoxy Design) for decorations Bandiera and Camelia.

INSTALLATION

Lea Ceramiche recommends laying Paillettes on perfectly flat walls.

To ensure Paillettes is installed correctly make sure the arrows on the back of each tile are turned in the same direction.

JOINTS

Lea Ceramiche recommande d'utiliser les mortiers suivants pour Paillettes:

- mastic blanc à base de ciment (contraste) pour toutes les couleurs.
- mastic époxy (Mapei Kerapoxy Design) pour les décorations Bandiera et Camelia.

POSE

Lea Ceramiche conseille de poser Paillettes sur des murs parfaitement plat.

Les carreaux Paillettes devront être posés en faisant attention au fait que la flèche présente au dos de chaque carreau soit orientée dans la même direction.

PUTZ

Lea Ceramiche empfiehlt bei der Serie Paillettes

- weißes Fugenmaterial (zum Kontrast) zu benutzen.
- Lea Ceramiche empfiehlt bei den Dekoren Bandiera und Camelia Epoxidfugenmaterial (Mapei Kerapoxy Design) zu verwenden.

VERLEGUNG

Lea Ceramiche empfiehlt die Verlegung der Serie Paillettes nur auf ganz glatten Wänden.

Bei der Verlegung der Paillettes Fliesen, bitte achten Sie, daß die Pfeile, die hinter der Fliese steht, unbedingt die gleiche Richtung der Verlegung folgt.

LECHADAS

Lea Ceramiche aconseja la lechada de la serie Paillettes con:

- lechada cementicia blanca (a contraste) para todos los colores.
- lechada epoxica (Mapei Kerapoxy Design) para los decorados Bandiera y Camelia.

COLOCACIÓN

Lea Ceramiche aconseja colocar Paillettes en una pared perfectamente plana.

Los azulejos de la serie PAILLETES deben ser colocadas asegurando que la flecha en la parte posterior de cada pieza, se enfrenta a la misma dirección.

TESSERAE



Mosaico Quadro



Mosaico Domino



Mosaico Muretto



Mosaico Muretto 3D



Mosaico Quadro 3D

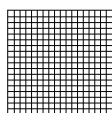

30,5x30,5cm/12"x12"
mosaico quadro

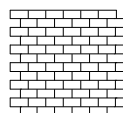

30,5x30,5cm/12"x12"
mosaico quadro 3D

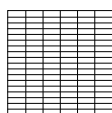

30,5x30,5cm/12"x12"
mosaico domino

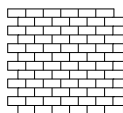

30,5x30,5cm/12"x12"
mosaico muretto

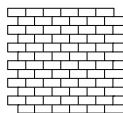

30,5x30,5cm/12"x12"
mosaico muretto 3D

Imballi pag. 435

Packing
Emballage
Verpackung
Embalajes

TRAVERTINO E MARMO NATURALI AL 100%

100% travertine stone and natural marbles
Travertin et marbre naturels à 100%
Travertin und Marmor 100%ig Naturstein
Travertino y mármol, naturales al 100%

SPESSORE

Thickness
Epaisseur
Stärke
Espesor
4 mm

STONALIZZAZIONE

Shading
Denuançage
Spielfarbig
Grado de tonalización

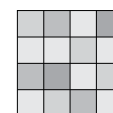

V3

MOSAICO SOTTILE IN PIETRA NATURALE

Slim mosaic in natural stone
Mosaïque fine et pierre naturelle
Dünnes Mosaik aus Naturstein
Mosaico de poco grosor, en piedra natural





tessereae domino sabbia 30,5x30,5cm / 12"x12"



tesserea quadro ghiaccio 30,5x30,5cm / 12"x12"



tesserea quadro verde 30,5x30,5cm / 12"x12"

Tesserae formati e colori

sizes and colors / formats et couleurs / formaten und farben / formatos y colores

quadro



sabbia quadro
30,5x30,5cm / 12"x12"
LG9T100 0770



ghiaccio quadro
30,5x30,5cm / 12"x12"
LG9T104 0770



verde quadro
30,5x30,5cm / 12"x12"
LG9T101 0770

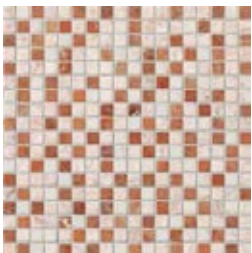

rosato quadro
30,5x30,5cm / 12"x12"
LG9T105 0770

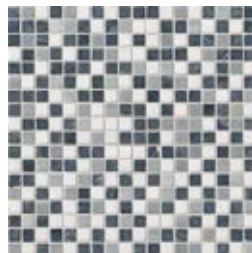

blu quadro
30,5x30,5cm / 12"x12"
LG9T102 0770

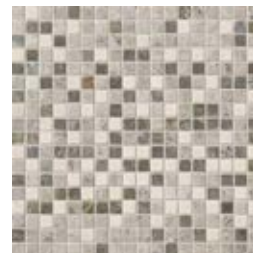

grigio quadro
30,5x30,5cm / 12"x12"
LG9T103 0770

domino

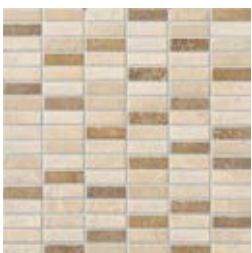

sabbia domino
30,5x30,5cm / 12"x12"
LG9T120 0650



grigio domino
30,5x30,5cm / 12"x12"
LG9T122 0650



verde domino
30,5x30,5cm / 12"x12"
LG9T121 0650

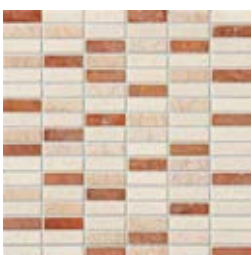

corallo domino
30,5x30,5cm / 12"x12"
LG9T123 0650

Tesserae corredi e pezzi speciali

trims and decors /
articles et pièces
spéciales /
formstücke und
dekore / decorados
y piezas especiales

muretto



gesso muretto
30,5x30,5cm / 12"x12"
LG9T111 0700



ocra muretto
30,5x30,5cm / 12"x12"
LG9T112 0700



grigio muretto
30,5x30,5cm / 12"x12"
LG9T115 0700



avorio muretto
30,5x30,5cm / 12"x12"
LG9T116 0700



bruno muretto
30,5x30,5cm / 12"x12"
LG9T113 0700



lavagna muretto
30,5x30,5cm / 12"x12"
LG9T110 0700



crema muretto
30,5x30,5cm / 12"x12"
LG9T117 0700

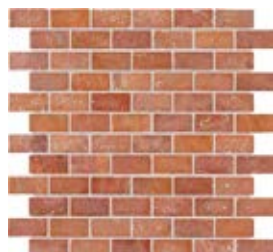

corallo muretto
30,5x30,5cm / 12"x12"
LG9T114 0700

LISTELLO

2x15cm / 3/4"x6"
avorio LG9T144 0140
bruno LG9T147 0140
corallo LG9T142 0140
crema LG9T146 0140
gesso LG9T141 0140
grigio LG9T143 0140
lavagna LG9T140 0140
ocra LG9T145 0140

CHAIR RAIL

1,5x15cm / 5/8"x6"
bruno LG9T131 0140
grigio LG9T133 0140
lavagna LG9T130 0140
rosato LG9T132 0140
verde LG9T134 0140

muretto 3D



gesso muretto 3D
30,5x30,5cm / 12"x12"
LG9T12D 0940



lavagna muretto 3D
30,5x30,5cm / 12"x12"
LG9T11D 0940



grigio quadro 3D
30,5x30,5cm / 12"x12"
LG9T10D 0940

A causa delle caratteristiche di pietra naturale, la varietà di colore e tonalità nel prodotto è da considerarsi normale. Questo aspetto deve essere preso in considerazione al momento dell'acquisto. È consigliato l'uso di un sealer protettivo dopo l'applicazione, si prega di prendere come riferimento le istruzioni del prodotto.

Due to inherent characteristics of natural stone, wide variety of shade and color are normal. This aspect has to be considered at the time of purchase. Sealing is recommended after installation, please refer to manufacturing instructions.

A cause des caractéristiques de la pierre naturelle, le changement de couleur et de tonalité du produit est à considérer normal. Cet aspect doit être pris en compte au moment de l'achat. Il est conseillé l'usage d'un produit de protection (sealer) après l'application, prière de se référer uniquement aux consignes indiquées sur le produit.

Aufgrund der Ähnlichkeit zum Naturstein, sind die Farb- und Tonalitätsabweichungen des Produkts als normal zu betrachten. Diese Eigenschaft soll beim Einkauf des Materials berücksichtigt werden. Ein Schutzmittel nach der Verlegearbeit wird empfohlen; wir bitten, die Anwendungshinweisungen des Mittels zu berücksichtigen.

Debido a las características de piedra natural, la variedad de colores y tonalidades del producto se considera normal. Este aspecto debe de ser tomado en consideración al momento de comprar el producto. Se debería de utilizar un "sellador" protector después de la aplicación y se ruega de tomar como referencia las instrucciones del producto.

APPENDICE TECNICA

TECHNICAL BOOKLET
APPENDICE TECHNIQUE
TECHNISCHER ANHANG
APÉNDICE TÉCNICO

- 362** **CERTIFICAZIONI**
CERTIFICATES - LES CERTIFICATS - ZERTIFIKATE - CERTIFICACIONE
- 384** **CARATTERISTICHE TECNICHE**
TECHNICAL SPECIFICATION - CARACTÉRISTIQUES TECHNIQUES
TECHNISCHE MERKMALE - CARACTERÍSTICAS TÉCNICAS
- 396** **PROTEZIONE ANTIBATTERICA**
MICROBAN
MICROBAN ANTIBACTERIAL PROTECTION - MICROBAN PROTECTION
ANTIBACTÉRIENNE - MICROBAN ANTIBAKTERIELLEN SCHUTZ
- 398** **POSA ELEMENTO ELLE E**
GRADINO CONTINUO
LAYING OF ELLE SHAPED ELEMENT AND CONTINUOUS STEP POSE
D'ÉLÉMENT À ELLE ET NEZ DE MARCHE CONTINUU - VERLEGUNG
DES ELLE-ELEMENTS UND DER DURCHGEHENDEN STUFEN
COLOCACIÓN ELEMENTO EN ELLE Y PELDAÑOS CONTINUOS
- 404** **INFORMAZIONI PER LA PULIZIA**
E LA MANUTENZIONE
CLEANING AND MAINTENANCE INFORMATION
INFORMATIONS SUR LE NETTOYAGE ET L'ENTRETIEN
INFORMATIONEN ZUR REINIGUNG UND PFLEGE
INFORMACIÓN PARA LA LIMPIEZA
- 425** **IMBALLI**
PACKING - EMBALLAGE - VERPACKUNG - EMBALAJES
- 438** **CONDIZIONI GENERALI DI VENDITA**
GENERAL SALES CONDITIONS - CONDITIONS GENERALES DE VENTE
ALLGEMEINE VERKAUFSKONDITIONEN
- 440** **DISCLAIMER**

LEA CERAMICHE SVILUPPO ECOSOSTENIBILE

LEA CERAMICHE E L'AMBIENTE

Da sempre LEA CERAMICHE considera la tutela dell'ambiente un aspetto di grande rilevanza

- investendo in modo deciso nell'acquisto delle migliori tecnologie presenti sul mercato per ridurre al minimo gli impatti ambientali delle proprie attività
- dotando tutti i dipendenti di un ambiente di lavoro ottimale
- ottenendo prestigiose certificazioni ambientali

Le collezioni più importanti di Lea Ceramiche hanno ottenuto il prestigioso marchio ecologico **ECOLABEL** (Reg. CE 66/2010), rilasciato dall'Unione Europea solo ai materiali con il più basso impatto ambientale.

Tutti i prodotti LEA CERAMICHE sono realizzati presso stabilimenti produttivi dotati di **Sistemi di Gestione Ambientale certificati**:

- **ISO 14001: 2004** (norma riconosciuta a livello internazionale)
- **EMAS** (Regolamento Europeo – Reg. CE 1221/09)

DOCUMENTAZIONI

Le **Dichiarazioni Ambientali EMAS** dei siti produttivi, i documenti che descrivono le prestazioni degli stabilimenti in termini di salvaguardia dell'ambiente e tutti gli obiettivi che LEA CERAMICHE si pone nell'ottica del miglioramento continuo, sono disponibili sul sito Internet www.ceramichelea.it.



LEA CERAMICHE SALVAGUARDIA DELL'AMBIENTE

L'incessante ricerca di prestazioni di eccellenza in merito al rispetto dell'ambiente ha condotto LEA CERAMICHE al costante rispetto dei seguenti principi.

RIUTILIZZO DEL 100% DEGLI SCARTI CRUDI



Il **100% degli scarti crudi** derivanti dal ciclo di produzione vengono **riutilizzati nella fase di preparazione dell'impasto**, contribuendo in modo sensibile alla salvaguardia delle risorse naturali riducendo l'estrazione di materie prime da cava.

RICICLO DEL 100% DEGLI SCARTI COTTI



Gli **scarti cotti**, che a seguito delle pregiate caratteristiche di qualità del prodotto non possono essere reinseriti nel ciclo di produzione, **sono completamente riciclati esternamente** come inerte per sottofondi di strade e edifici, riducendo così l'uso di ghiaia ed inerti naturali comunemente utilizzati dall'industria delle costruzioni.

RICICLO DEL 100% DEI RIFIUTI NON CERAMICI



Il **100% dei rifiuti non ceramici** derivanti dalle attività produttive è **gestito in modo differenziato** e riciclato presso ditte esterne autorizzate.

RIUTILIZZO DEL 100% DELLE ACQUE DI PROCESSO



La produzione di piastrelle di ceramica richiede ingenti quantitativi di acqua. Per salvaguardare questa importante risorsa naturale LEA CERAMICHE **riutilizza il 100% delle acque reflue** derivanti dal ciclo di produzione, generando una **riduzione del 60 % del fabbisogno idrico degli stabilimenti**.

BASSE EMISSIONI IN ATMOSFERA



Gli importanti investimenti attuati nelle migliori tecnologie a disposizione permettono di realizzare i prodotti LEA CERAMICHE **riducendo al minimo le emissioni gassose in atmosfera**, raggiungendo livelli 10 volte inferiori ai severi limiti ambientali richiesti della legislazione italiana (rif. **Protocollo di Kyoto** riguardante la riduzione delle emissioni di gas a effetto serra).

POLITICA ENERGETICA



Il recupero del calore contenuto nei fumi di cottura permette di ridurre l'uso del gas naturale necessario per la preparazione dell'impasto. Le tecnologie adottate in questo ambito consentono di raggiungere una **riduzione del 25% nell'utilizzo di metano**.

UTILIZZO DI IMBALLAGGI 100% RICICLABILI



I **materiali impiegati per gli imballaggi** dei prodotti LEA CERAMICHE (quali scatole, cartone, plastica, palette in legno, etc.) sono **completamente riciclabili**.

PALLET FAO



LEA CERAMICHE utilizza pallet senza corteccia **conformi allo standard IPPC / FAO ISPM 15**, offrendo quindi ai Paesi importatori ogni garanzia per la salvaguardia del proprio patrimonio forestale.

CONTRIBUTO ALL'OTTENIMENTO DI CREDITI LEED



LEED 4:

le nuove schede LEED 4 delle collezioni Lea Ceramiche saranno disponibili appena il nuovo LEED Rating System 4 sarà pubblicato da USGBC.

LEA CERAMICHE è membro del **U.S. Green Building Council**, organizzazione degli Stati Uniti che promuove la realizzazione di edifici ed opere nel rispetto dell'ambiente, della salute e del benessere delle persone che ci vivono e lavorano.

Credito SS 7.1 - Effetto Isola di Calore / non per i tetti (LEED NC, CI, CS, SCHOOLS): 1 punto LEED è riconosciuto se in esterno si utilizzano materiali con $SRI \geq 29$.

La gran parte dei prodotti Lea Ceramiche **non contribuisce ad aumentare la temperatura delle zone urbane rispetto a quelle rurali** (No Effetto Isola di Calore), in quanto possiedono Indice di Riflettanza Solare $SRI \geq 29$.

Credito EA 1 - Ottimizzazione delle Prestazioni Energetiche (LEED NC, CI, CS, SCHOOLS):

la conducibilità termica λ del gres porcellanato Lea Ceramiche è di 1,3 Watt/m²K (1,1 Kcal/m h °C).

Per questo è particolarmente indicato per sistemi di riscaldamento a pavimento e pareti ventilate. La conducibilità termica λ del rivestimento in monocottura Lea Ceramiche è di 0,7 Watt/m² K (0,6 Kcal/m h °C).

Credito MR 2 – Gestione degli Scarti di Costruzione (LEED NC, CI, CS, SCHOOLS): 2 punti LEED sono riconosciuti se in cantiere viene riciclato almeno il 75% in peso delle materie prime – materiali ed imballaggi.

Le piastrelle Lea Ceramiche e i loro imballaggi (scatole di cartone, termoretraibili e reggette in plastica, pallet di legno) **sono riciclabili al 100%**. Inoltre la gestione in cantiere è molto agevole perché le quantità di scarti da riciclare sono minime (il peso degli imballaggi è solo il 2-3% rispetto al peso totale del materiale).

Credito MR 4 – Contenuto di Materiale Riciclato Recycled Content (LEED NC, CI, CS, SCHOOLS): 2 punti LEED sono assegnati se “% scarto post-consumer waste + ½ % scarto pre-consumer $\geq 20\%$ rispetto al totale delle materie prime, valore basato sui costi”.

Il contenuto di **materiale riciclato “pre-consumo” delle principali serie Lea Ceramiche è del 40%**, come certificato da ente esterno qualificato. Il certificato è disponibile sul sito www.ceramichelea.it.

Credito MR 5 - Utilizzo di Materiali Locali (LEED NC, CS, SCHOOLS): 2 punti LEED sono assegnati se l'uso di materiali locali incide per almeno il 20% sul totale del costo delle materie prime).

• Questi Crediti LEED si applicano agli edifici costruiti entro 500 miglia (804,5 km) dagli stabilimenti produttivi Lea Ceramiche (Finale Emilia - MO, Italy; Toano - RE, Italy; Fiorano Modenese - MO, Italy; Aveiro, Portugal; Lawrenceburg - Kentucky, USA).

• Il contributo % in valore delle piastrelle Lea Ceramiche al singolo progetto LEED si calcola sulla base della posizione geografica del cantiere.

Credito MR 5 - Utilizzo di Materiali Locali (solo LEED CI):

• **1 punto LEED:** utilizzare almeno il 20% del valore totale di materiali e prodotti fabbricati localmente entro un raggio di 500 miglia (804,5 km) dagli stabilimenti produttivi di Lea Ceramiche (Finale Emilia - MO, Italy; Toano - RE, Italy; Fiorano Modenese - MO, Italy; Aveiro, Portugal; Lawrenceburg - Kentucky, USA).

• **2 punti LEED:** deve essere soddisfatto il punto sopra, inoltre utilizzare almeno il 10% del valore totale di materie prime e prodotti, estratti, raccolti, recuperati o fabbricati entro le 500 miglia (804,5 km) dalla sede dell'edificio LEED.

Credito IEQ 4.1 – Contenuto di VOC, Adesivi e Sigillanti (LEED NC, CI, CS, SCHOOLS): 1 punto LEED è raggiunto se tutti gli adesivi e sigillanti usati per interni sono conformi al Regolamento SCAQMD #1168 (il limite di VOC degli additivi per ceramica non deve superare i 65 g/l senza acqua).

Credito IEQ 4.3 - Contenuto di VOC, Pavimentazioni (LEED NC, CI, CS, SCHOOLS): 1 punto LEED viene assegnato se tutta la pavimentazione è conforme ai requisiti previsti in questo Credito.

Le piastrelle Lea Ceramiche permettono di ottenere 1 punto LEED perché non contengono Sostanze Organiche Volatili VOC (cfr. Regolamenti LEED 2009 NC, CI, CS, SCHOOLS).

Credito IEQ 4.6 - Contenuto di VOC, Pareti e Controsoffitti (solo LEED SCHOOLS): 1 punto LEED.

Le piastrelle Lea Ceramiche permettono di ottenere 1 punto LEED perché non contengono Sostanze Organiche Volatili VOC (cfr. Addenda of LEED Reference Guide for Green Building Design and Construction, 2009 Edition).

Credito ID 1 - Innovation in Design: 1-5 punti LEED per NC, CI e CS, 1-4 punti LEED per SCHOOLS.

• **“Innovation in Design”:** le più importanti serie Lea Ceramiche possiedono il prestigioso marchio ecologico **ECOLABEL** (CE 66/2010), basato sull'Analisi del Ciclo di Vita del prodotto (LCA) e rilasciato dall'UE solo ai materiali con il più basso impatto ambientale.

• **“Innovation in Design”:** nella gamma prodotti Lea Ceramiche sono disponibili serie caratterizzate da superficie antibatterica, con riduzione dei batteri fino al 99,9% (metodo ISO 22196).

• **“Prestazione esemplare” Credito MR 2 - GESTIONE DEGLI SCARTI DI COSTRUZIONE: 1 punto LEED** è riconosciuto se in cantiere viene riciclato almeno il 95% in peso delle materie prime – materiali ed imballaggi: le piastrelle Lea Ceramiche e i loro imballaggi (scatole di cartone, termoretraibili e reggette in plastica, pallet di legno) **sono riciclabili al 100%**.

• **“Prestazione esemplare” Credito IEQ 4.6 - Contenuto di VOC, Pareti e Controsoffitti (specifico per LEED SCHOOLS): 1 punto LEED** è ottenuto per edifici LEED NC, CI, CS. Le piastrelle LEA Ceramiche permettono di ottenere 1 punto LEED perché non contengono Sostanze Organiche Volatili VOC (cfr. Addenda of LEED Reference Guide for Green Building Design and Construction, 2009 Edition).

Credito RP 1- Priorità Regionali (LEED NC, CI, CS, SCHOOLS): 1-4 punti LEED.

L'edificio può guadagnare da 1 a 4 punti LEED tra i 6 crediti prioritari di rilevante importanza locale individuati nelle diverse regioni dagli USGBC regionali e chapters. Un database con i Crediti Prioritari nelle diverse Regioni e la loro applicabilità è disponibile sul sito www.usgbc.org.

LEED per Edifici Esistenti (EBOM) – Operazioni di Manutenzione.

Le procedure di pulizia e manutenzione delle superfici piastrellate riportate nel catalogo generale Lea Ceramiche permettono di raggiungere i seguenti LEED Credits:

• **Credito SS 7.1 – RIDUZIONE DELL'EFFETTO ISOLA DI CALORE (no tetti): 1 punto LEED** viene assegnato se è operativo un piano di manutenzione che assicuri che le superfici sono pulite almeno ogni 2 anni per mantenere una buona riflettanza.

• **IEQ 3.1 – PULIZIE SOSTENIBILI, PROGRAMMA PULIZIE AD ALTE PRESTAZIONI: 1 punto LEED.**

• **IEQ 3.3 – PULIZIE SOSTENIBILI, ACQUISTO DI DETERGENTI E MATERIALI SOSTENIBILI: 1 punto LEED.**

MR 3 – Acquisti Sostenibili, Modifiche e Ristrutturazioni degli Edifici: 1 punto LEED viene ottenuto se i materiali acquistati contengono almeno il 10% di scarti post-consumo e/o il 20 % di scarti pre-consumo.

Il contenuto di **materiale riciclato “pre-consumo” delle principali serie LEA CERAMICHE è del 40%**, come certificato da ente esterno qualificato. Il certificato è disponibile sul sito www.leaceramiche.it.

NC = LEED 2009 nuove costruzioni, CI = LEED 2009 interni commerciali, CS = LEED 2009 strutture e involucro di edifici, SCHOOLS = LEED 2009 scuole, EBOM = LEED 2009 edifici esistenti e manutenzioni.

Lea Ceramiche è membro del **Green Building Council ITALIA**, organizzazione che promuove la realizzazione di edifici ed opere nel rispetto dell'ambiente, della salute e del benessere delle persone che ci vivono e lavorano.

I Crediti ottenibili dalle piastrelle LEA CERAMICHE con LEED NC 2009 Italia (Nuove Costruzioni) sono gli stessi ottenibili con USGBC LEED NC 2009 Rating System (v. tabella). Le uniche differenze riguardano i Crediti **MR 5 - MATERIALI REGIONALI** (diverso meccanismo di calcolo della distanza del sito produttivo e delle materie prime dal cantiere) ed **IEQ 4.1 - CONTENUTO DI VOC-ADESIVI E SIGILLANTI** (max emissioni di VOC = 200 mg/m³, v. GEV Emissioni EC1 ed. 03.03.2009).



LEA CERAMICHE 100% ECO FRIENDLY

LEA CERAMICHE AND THE ENVIRONMENT

Lea Ceramiche has always considered environmental protection a matter of great importance

- investing in the best technologies on the market to minimize the environmental impact of its activities
- giving all employees an excellent working environment
- obtaining prestigious environmental certifications

The most important collections of Lea Ceramiche have been awarded the prestigious **ECOLABEL** (EC regulation 66/2010), issued by the European Union only to those products with the lowest environmental impact.

All LEA CERAMICHE products are manufactured in production sites that are certified with

Environmental Management Systems:

- **ISO 14001: 2004** (internationally recognized standard)
- **EMAS** (European Regulation - EC Reg 1221/09)



DOCUMENTATION

The **EMAS Environmental Statements** of the production sites, documents describing the performance of production sites and all the objectives LEA Ceramiche strives to achieve in terms of environmental safeguard, are available on the website www.ceramichelea.it.

LEA CERAMICHE CARES FOR THE ENVIRONMENT

LEA CERAMICHE's incessant strive for excellence has led us to respect the following principles when dealing with the environment.



100% INDUSTRIAL WASTE REUSED – NON FIRED TILES

The totality of the non fired material, which does not comply with our high quality standards, **is reused in the production cycle**. As these products are not yet fired, they can be reinserted in the initial phases of the production cycle. **Recycling of this waste also reduces the need of raw materials.**



100% INDUSTRIAL WASTE RECYCLED – FIRED TILES

On the other hand the fired material cannot be recycled into the production cycle. For this reason **all fired material is recycled externally and used in the construction industry**. These waste products are used as a foundation in the construction of roads – this reduces the need of the natural resources which are commonly used for this purpose.



100% INDUSTRIAL WASTE RECYCLED – NON CERAMIC WASTE

The totality of the non ceramic waste is differentiated and recycled externally.



100 % WASTE WATER RECYCLED – SAFEGUARD OF NATURAL RESOURCES

The production of tiles requires important amounts of water. So as to safeguard this precious resource **LEA CERAMICHE recycles 100% of waste water from the production cycle**. **This allows the reduction of water consumption by 60%**. None of the water used in the production cycle is discharged into the ecosystem.



LOW GAS EMISSIONS INTO THE ATMOSPHERE

LEA CERAMICHE **complies strictly to Italian Standards (cfr Post-Kyoto Protocol negotiations on greenhouse gas emissions)**. The strive for excellence has led us to invest in high quality technology that keeps **our emissions 10 times inferior the allowed limits**.



ENERGY SAVING

Through a complex piping system LEA CERAMICHE manages to conserve the heat emitted during the firing process and reuses it in the preparation of the mix used for the body – this **reduces the need in methane by 25%**.



100% RECYCLABLE MATERIAL USED FOR PACKING

The materials used for the packing of LEA CERAMICHE products are **completely recyclable**. These materials include carton boxes, plastic materials, wooden pallets, etc.



FAO PALLETS

For shipments LEA CERAMICHE uses debarked pallets (DB), **in accordance with the IPPC / FAO ISPM 15 standards**. This is a further warranty for the forest safeguard of countries importing LEA CERAMICHE products.

LEED CREDIT SYSTEM



LEED 4:

The new LEED 4 features for the Lea Ceramiche collections will be available as soon as the new LEED Rating system 4 will be published by the USGBC.

LEA CERAMICHE is a member of the **U.S. Green Building Council**: this is an organisation that promotes buildings that are environmentally friendly, profitable and healthy places to live and work in.

SS Credit 7.1 - Heat Island Effect / Non roof (NC, CI, CS, SCHOOLS LEED Rating Systems): 1 LEED point is granted for the use of hardscape materials with SRI ≥ 29 .

The great majority of Lea Ceramiche products **do not contribute to change the energy balance of the environments where they are installed**. They do not produce any Urban Heat Island Effect, thanks to their very good physical properties, i.e. Solar Reflectance Index SRI ≥ 29 .

EA Credit 1 - Optimize Energy Performance (NC, CI, CS, SCHOOLS LEED Rating Systems)

The Thermal conductivity λ of Lea Ceramiche porcelain tiles is 0.75 Btu/ft h °F (1.3 Watt/m²K or 1.1 Kcal/m h °C). For this reason it is ideal for heating floors systems and external cladding. **The Thermal conductivity** λ of Lea Ceramiche wall tiles is 0.4 Btu/ft h °F (0.7 Watt/m²K or 0.6 Kcal/m h °C).

MR Credit 2 - Construction Waste Management (NC, CI, CS, SCHOOLS LEED Rating Systems): 2 LEED points are granted if at least 75% of the weight of Raw materials – tiles and packing - will be recycled.

Lea Ceramiche tiles and their packing material (carton boxes, plastic packaging materials, wooden pallets, straps, etc..) **are 100% recyclable**. The management of the waste on the building site is also easier because the quantity of waste is very small (weight of packaging is around 2-3% of weight of total material).

MR Credit 4 - Recycled Content (NC, CI, CS, SCHOOLS LEED Rating Systems): 2 LEED points are granted if the % post-consumer waste + 1/2 of the % pre-consumer waste $\geq 20\%$ of the total raw materials, based on cost.

The great majority of Lea Ceramiche products are produced with **40% of pre-consumer recycled materials**, as certified by a qualified external company. The certificate is available on the website www.ceramichelea.it.

MR Credit 5 - Regional Materials (NC, CS, SCHOOLS LEED Rating Systems): 2 LEED points are granted if the use of local raw materials is equal to 20% of the total materials value, based on cost.

- These Credits are applicable for buildings constructed within 500 miles (804.5 km) from Lea Ceramiche production sites (Finale Emilia MO, Italy; Toano RE, Italy; Aveiro, Portugal; Lawrenceburg Kentucky, USA).
- The % contribution based on the cost of Lea Ceramiche tiles to a single LEED project is calculated based on the geographical position of the construction site.

MR Credit 5 - Regional Materials (CI Rating Systems Only): 2 LEED points are granted if the use of local raw materials is equal to 20% of the total materials value, based on cost.

- **1 LEED Point**: use a minimum of 20% of the combined value of construction and Division 12 (Furniture) materials and products that are manufactured regionally within a radius of 500 miles from Lea Ceramiche production sites (Finale Emilia MO, Italy; Toano RE, Italy; Aveiro, Portugal; Lawrenceburg Kentucky, USA).
- **2 LEED Points**: meet the previous criterion requirement and use a minimum of 10% of the combined value of construction and Division 12 (Furniture) materials and products extracted, harvested or recovered, as well as manufactured, within 500 miles of the project.

IEQ Credit 4.1 - Low Emitting Materials, Adhesives and Sealants (NC, CI, CS, SCHOOLS LEED Rating Systems): 1 LEED point is granted if all adhesives and sealants used on the interior of the building comply with SCAQMD Rule #1168 (VOC limit of ceramic adhesives not more than 65 g/l less water).

IEQ Credit 4.3 - Low Emitting Materials, Flooring Systems (NC, CI, CS, SCHOOLS LEED Rating Systems): 1 LEED point is granted if all flooring complies with the requirements indicated in IEQ Credit 4.3 Section.

Lea Ceramiche tiles obtain 1 LEED point because they do not contain any Volatile Organic Compounds VOC (see LEED 2009 NC, CI, CS, SCHOOLS Rating Systems).

IEQ Credit 4.6 - Low Emitting Materials, Ceiling and Wall Systems (SCHOOLS LEED Rating System only): 1 LEED point.

Lea Ceramiche tiles obtain 1 LEED point because they do not contain any Volatile Organic Compounds VOC (see Addenda of LEED Reference Guide for Green Building Design and Construction, 2009 Edition).

ID Credit 1 - Innovation in Design: 1-5 LEED points for NC, CI and CS, 1-4 LEED points for SCHOOLS

- **"Innovation in Design"**: the main collections of Lea Ceramiche have got the prestigious ecological mark **ECOLABEL** (CE 66/2010), based on the product LCA (Life Cycle Assessment) and awarded by the EU only to those products with the lowest environmental impact.
- **"Innovation in Design"**: within the range of Lea Ceramiche products, some series are available with antibacterial surfaces, that reduce bacterial presence by up to 99.9 % (ISO 22196 test method)
- **"Exemplary performances" MR Credit 2 - CONSTRUCTION WASTE MANAGEMENT: 1 LEED point** may be earned if at least 95% by weight of the Raw Materials - material and packing - will be recycled. Lea Ceramiche tiles and their packing material (carton boxes, plastic packaging materials, wooden pallets, straps, etc..) **are 100% recyclable**.
- **"Exemplary performances" IEQ Credit 4.6 - LOW EMITTING MATERIALS, CEILING and WALL SYSTEMS: 1 LEED point** may be earned for NC, CI, CS LEED Buildings: no traces of VOC (Volatile Organic Compounds) are present in LEA Ceramiche tiles (see Addenda of LEED Reference Guide for Green Building Design and Construction, 2009 Edition).

RP Credit 1- Regional Priority (NC, CI, CS, SCHOOLS LEED Rating Systems): 1-4 LEED points.

Between 1 and 4 credits can be obtained, of the 6 Regional Priority credits identified by the USGBC regional councils and chapters, if the project has an environmental importance for the region, where it is being constructed. A database of Regional Priority credits and their geographic applicability is available on the USGBC website www.usgbc.org.

LEED Rating System of Existing Buildings Operations and Maintenance (EBOM)

The cleaning and maintenance procedures on Lea Ceramiche's general catalogue can help obtain the following LEED credits.

- **SS Credit 7.1 - HEAT ISLAND REDUCTION (Non roof): 1 LEED point** is granted if a maintenance program is organized, that ensures the surfaces are cleaned at least every 2 years to maintain a good reflectance.
- **IEQ 3.1 - GREEN CLEANING, HIGH PERFORMANCE CLEANING PROGRAM: 1 LEED point**.
- **IEQ 3.3 - GREEN CLEANING, PURCHASE OF SUSTAINABLE CLEANING PRODUCTS AND MATERIALS: 1 LEED point**.

MR 3 - Sustainable Purchasing, Facility Alterations and Additions: 1 LEED point is granted if the purchases contain at least 10 % post-consumer waste and/or 20 % pre-consumer waste material

The great majority of Lea Ceramiche products are produced with **40% of pre-consumer recycled materials**, as certified by a qualified external company. The certificate is available on the website www.ceramichelea.it.

NC = LEED 2009 for New Construction, CI = LEED 2009 for Commercial Interior, CS = LEED 2009 for Core and Shell Development, SCHOOLS = LEED 2009 for Schools, EBOM = LEED 2009 for Existing Buildings Operations and Maintenance.

Lea Ceramiche is a member of the **Green Building Council ITALIA**, this is an organisation that promotes in Italy buildings that are environmentally friendly, profitable and healthy places to live and work in.

The LEED credits that can be obtained with Lea Ceramiche tiles for NC 2009 Italia (New construction) are the same as the ones that can be obtained with USGBC LEED NC 2009 Rating System (please see table). The only differences are regarding credit **MR 5 - REGIONAL MATERIALS** (different method of calculating the distance from the production site and raw materials from the construction site) and **IEQ 4.1 - LOW EMITTING MATERIALS, ADHESIVE AND SEALANTS** (max emissions VOC = 200 mg/m³, v. GEV Emicode EC1 ed. 03.03.2009).



LEA CERAMICHE PRESERVATION DE L'ENVIRONNEMENT

La recherche incessante de prestations d'excellence afin de préserver l'environnement a conduit LEA CERAMICHE au suivi constant des principes suivants.



REUTILISATION DE 100% DES DÉCHETS BRUTS

100% des déchets bruts provenant du cycle de production sont réutilisés pendant la phase de préparation de la pâte, contribuant sensiblement à la préservation des ressources naturelles réduisant l'extraction de matières premières minières.



RECYCLAGE DE 100% DES DÉCHETS CUITS

Les déchets cuits, qui selon les normes de qualité du produit ne peuvent pas être réinsérés dans le cycle de production, sont complètement recyclés en externe en matériaux inertes pour les couches de fondation des routes et des bâtiments, réduisant de ce fait l'utilisation de gravillons et en matériaux inertes naturels communément utilisés par l'industrie du bâtiment.



RECYCLAGE DE 100 % DES DÉCHETS NON CÉRAMIQUES

100 % des déchets non céramiques provenant des activités de fabrication, sont triés de façon sélective et recyclés auprès d'entreprises extérieures autorisées.



RÉUTILISATION DE 100% DES EAUX DE TRAITEMENT

La production de carrelages demande une quantité d'eau considérable. Pour préserver cette ressource naturelle importante LEA CERAMICHE réutilise 100% des eaux provenant du cycle de production, générant une réduction de 60 % des besoins hydrauliques des usines.



BASSES ÉMISSIONS DANS L'ATMOSPHÈRE

Les importants investissements actuels dans les meilleures technologies qui sont à notre disposition permettent de réaliser les produits LEA CERAMICHE, **en réduisant au minimum les émissions de gaz dans l'atmosphère**, et en atteignant des niveaux dix fois inférieurs aux limites environnementales très sévères fixées par la législation italienne (réf. **Protocole de Kyoto** concernant la réduction des émissions de gaz à effet de serre).



POLITIQUE SUR L'ÉNERGIE

La récupération de la chaleur contenue dans les fumées de cuisson permet de réduire l'utilisation du gaz naturel nécessaire à la préparation de la pâte. Les technologies adoptées dans cette optique tendent à atteindre une réduction de 25% d'utilisation de méthane.



UTILISATION D'EMBALLAGES 100% RECYCLABLES

Les matériaux utilisés pour les emballages des produits LEA CERAMICHE (dont des boîtes, du carton, du plastique, des palettes en bois, etc.) sont complètement recyclables.



PALETTES FAO

LEA CERAMICHE utilise des palettes sans écorce (DB) conformes aux normes IPPC / FAO ISPM 15, offrant donc aux Pays importateurs la garantie de la préservation du patrimoine forestier.

LEA CERAMICHE UMWELTSCHUTZ

Das unaufhörliche Bestreben nach hervorragenden Leistungen hinsichtlich der Umwelt brachte LEA CERAMICHE zur ständigen Einhaltung folgender Prinzipien.



WIEDERVERWERTUNG VON 100 % DER ROHABFÄLLE

100 % der Rohabfälle aus dem Produktionszyklus werden in der Vorbereitungsphase des Gemisches wiederverwertet und tragen somit ihren Teil zum Schutz der Naturressourcen bei, indem sie den Abbau von Rohmaterialien verringern.



WIEDERVERWERTUNG VON 100 % DER KOCHABFÄLLE

Kochabfälle, die aufgrund der hervorragenden qualitativen Eigenschaften des Produktes nicht in den Produktionszyklus zurückgeführt werden können, werden zur Gänze extern als inerte Materialien für den Unterbau von Straßen und Gebäuden verwendet, wodurch die Verwendung von Kies und natürlichen inerten Materialien, die in der Baubranche Anwendung finden, reduziert wird.



100% RECYCLING DES NICHT KERAMISCHEN ABFALLS

100 % des während dem Produktionsprozess anfallenden **keramischen Abfalls** wird **getrennt gesammelt** und von öffentlich-rechtlichen Entsorgungsbetrieben recycelt.



WIEDERVERWERTUNG VON 100 % DES ABWASSERS

Die Herstellung von Keramikfliesen erfordert beträchtliche Wassermengen. Um diese wichtige Naturressource zu schützen, verwertet LEA CERAMICHE 100 % der Abwässer des Produktionszyklus wieder und ermöglicht somit eine Reduktion des Wasserbedarfs in den Anlagen um 60 %.



NIEDRIGE EMISSIONSWERTE

Dank der starken Investitionen in die modernsten, verfügbaren Produktionstechnologien ist es uns möglich, sämtliche Produkte von LEA CERAMICHE so herzustellen, dass **die Schadstoffemissionen in die Atmosphäre auf das Geringste reduziert werden.** Wir erreichen dabei ein Niveau, das 10 mal unter den strengen Grenzwerten der italienischen Gesetzgebung liegt (siehe dazu das **Kyoto Protokoll** in Bezug auf die Emissionsreduzierung von schädlichen und giftigen Treibhausgasen).



ENERGIEPOLITIK

Die Wiederverwendung der Wärme in den Brennöfen ermöglicht bei der Vorbereitung des Gemisches die Reduktion von Erdgas. Die in diesem Bereich angewandten Technologien ermöglichen eine Reduktion des Methanverbrauchs um 25 %.



VERWENDUNG VON 100 % RECYCLEBAREN VERPACKUNGEN

Die Materialien, die zur Verpackung der Produkte von LEA CERAMICHE verwendet werden (Schachteln, Kartons, Kunststoffe, Holzpaletten, usw.) sind vollständig recyclebar.



FAO-PALETTE

LEA CERAMICHE verwendet gemäß dem Standard IPPC/FAO ISPM 15 Paletten ohne Rinde (DB) und gibt daher den Importländern die Garantie, den eigenen Waldbestand zu schützen.

LEA CERAMICHE SALVAGUARDIA DEL MEDIO AMBIENTE

La incesante búsqueda de prestaciones de excelencia basadas en el respeto al medio ambiente ha llevado a LEA CERAMICHE a respetar de forma constante los siguientes principios.



REUTILIZACIÓN DEL 100% DE LOS RESIDUOS CRUDOS

El 100% de los residuos crudos derivados del ciclo de producción se reutilizan en la fase de preparación del empaste, contribuyendo de manera sensible a la salvaguardia de los recursos naturales reduciendo la extracción de materias primas de la cantera.



RECICLADO DEL 100% DE LOS RESIDUOS COCIDOS

Los residuos cocidos que a consecuencia de las prestigiosas características de calidad del producto no pueden volver a introducirse en el ciclo de producción, son reciclados externamente por completo como inertes para fondos de carretera y edificios, reduciendo de esta forma el uso de grava e inertes naturales comúnmente utilizados por la industria de la construcción.



RECICLAJE DEL 100% DE LOS DESPERDICIOS NO CERÁMICOS

El 100 % de los desperdicios no cerámicos derivados de las actividades productivas se maneja de manera diferenciada y se recicla en compañías externas autorizadas.



REUTILIZACIÓN DEL 100% DE AGUAS DE PROCESO

La producción de baldosas de cerámica requiere cantidades ingentes de agua. Para salvaguardar este recurso natural tan importante, LEA CERAMICHE reutiliza el 100% de las aguas residuales derivadas del ciclo de producción, generando una reducción del 60% de las necesidades hídricas de las fábricas.



BAJA EMISIÓN A LA ATMÓSFERA

Las importantes inversiones actuales en las mejores tecnologías a disposición permiten realizar los productos de LEA CERAMICHE reduciendo al mínimo las emisiones de gas en la atmósfera, alcanzando niveles 10 veces inferiores a los severos límites ambientales establecidos por la legislación italiana (ref. Protocolo de Kioto relacionado con la reducción de las emisiones de gas de efecto invernadero).



POLÍTICA ENERGÉTICA

La recuperación del calor contenido en los humos de cocción permite reducir el uso de gas natural necesario para la preparación del empaste. Las tecnologías adoptadas en este ámbito permiten reducir el uso de metano al 25%.



USO DE EMBALAJES 100% RECICLABLES

Los materiales empleados para los embalajes de los productos LEA CERAMICHE (como cajas, cartones, plásticos, palés de madera, etc.) son completamente reciclables.



PALÉ FAO

LEA CERAMICHE utiliza palés sin corteza (DB) según la norma IPPC / FAO ISPM 15, ofreciendo a los países importadores todas las garantías para la salvaguardia de su patrimonio forestal.

ECOLABEL

marchio europeo che certifica la “qualità ecologica” dei prodotti a basso impatto ambientale nell’intero ciclo di vita

european stamp of approval for “ecological quality” of products with low impact on the environment for entire lifecycle

label européen certifiant la “qualité écologique” des produits au moindre impact environnemental dans le cycle de vie tout entier

europäisches umweltgütezeichen für die “ökologische qualität” von produkten, d.h. hohe umweltverträglichkeit während des gesamten lebenszyklus

certificación europea que ratifica la “calidad ecológica” de los productos de bajo impacto ambiental en su ciclo vital



ITA

Ecolabel è un sistema di certificazione ambientale di prodotto, creato dalla Comunità Europea (Regolamento CE n. 66/2010), che dà a tutti i consumatori la possibilità di acquistare merci eco-compatibili, contribuendo concretamente alla salvaguardia ed al miglioramento dell’eco-sistema e di conseguenza della qualità della vita. Ogni prodotto Ecolabel è contrassegnato col marchio di una margherita. Questa etichetta rappresenta un attestato di eccellenza, perché viene concessa in base a una rigorosa analisi del ciclo di vita (LCA). Per ogni prodotto vengono presi in considerazione tutti gli aspetti ambientali in ogni fase produttiva, dalle materie prime allo smaltimento: la qualità dell’aria e dell’acqua, la protezione dei suoli, la riduzione dei rifiuti, il risparmio energetico, la gestione delle risorse naturali, la protezione della fascia di ozono, l’impatto sulle biodiversità. Le piastrelle Lea Ceramiche sono materiali completamente inerti, e al termine del loro utilizzo possono essere riciclate come sottofondi di strade e edifici. Maggiori informazioni sono disponibili sul sito internet del marchio ECOLABEL <http://www.ecolabel.eu>. Il marchio ECOLABEL è stato ottenuto da Lea Ceramiche per i prodotti appartenenti alle seguenti serie: Tecnoquartz, Stonehenge, Basaltina Stone Project, Bioessenze, Midtown, Masterplan.

ENG

Ecolabel is an environmental certification for a product, created by the European Union (CE n. 66/2010). It is done so as to allow all consumers to buy “green” products that are eco-compatible, and to contribute concretely to the safeguard the eco-system and improve our standard of living. All the Ecolabel products are marked with a clearly visible daisy. This label is a proof of excellence, because it is given after a thorough analysis of the product life cycle (LCA). For each product all the environmental aspects are considered in the production phase, from raw material to the destruction of the flooring: the quality of the air and water, protection of soils, reduction of waste, energy consumption, management of natural resources, protection of the ozone layer, and impact on biodiversity. Tiles by Lea Ceramiche are totally inert materials and, after their regular use, can be recycled as substrates for roads and buildings. More info available on the Ecolabel website <http://www.ecolabel.eu>. The following collections by Lea Ceramiche have received the ecolabel certification: Tecnoquartz, Stonehenge, Basaltina Stone Project, Bioessenze, Midtown, Masterplan.

FRA

Ecolabel est un système de certification écologique de produit mis en place par la Communauté européenne (Règlement CE n° 66/2010). Il donne à l’ensemble des consommateurs la possibilité d’acheter des produits écologiquement efficaces et de contribuer ainsi à la sauvegarde et à l’optimisation de l’écosystème et, par conséquent, de la qualité de vie. Chaque produit Ecolabel s’accompagne d’une marguerite. Ce label constitue un certificat d’excellence, car il n’est délivré qu’après une analyse scrupuleuse du cycle de vie (ACV). Pour chaque produit, tous les aspects environnementaux sont examinés à toutes les étapes de la production, des matières premières à l’élimination des déchets : la qualité de l’air et de l’eau, la protection des sols, la réduction des déchets, l’économie d’énergie, la gestion des ressources naturelles, la protection de la couche d’ozone, l’impact sur la biodiversité. Les Produits Lea Ceramiche sont des matériaux totalement inertes, et à la fin de leur utilisation peuvent être recyclés comme les fondations de routes et de bâtiments. Plus d’informations sont disponibles sur le site de l’Ecolabel www.ecolabel.eu.

La marque Ecolabel a été obtenue par Lea Ceramiche pour les collections suivantes : Tecnoquartz, Stonehenge, Basaltina Stone Project, Bioessenze, Midtown, Masterplan.

DEU

Das Ecolabel, EU-Umweltzeichen von der Europäischen Union ins Leben gerufen (Verordnung (EG) Nr. 66/2010), bietet allen Verbrauchern die Möglichkeit, umweltfreundliche Produkte zu kaufen und somit konkret zum Schutz und der Verbesserung des Ökosystems sowie der damit verbundenen Lebensqualität beizutragen. Alle Produkte, die mit diesem Zeichen ausgezeichnet sind, sind mit einer Margerite gekennzeichnet, die nach einer strengen Analyse der Produktlebensdauer gewährt wird. Bei allen Produkten werden in der Herstellungsphase alle Umweltaspekte berücksichtigt, von den Rohstoffen bis hin zur Entsorgung, Luft- und Wasserqualität, Schutz des Grundwassers, Abfallreduzierung, Energieersparnis, Management der Naturressourcen, Schutz der Ozonschicht, Auswirkung auf die biologische Vielfalt. Die Keramikfliesen von LEA CERAMICHE bestehen aus komplettem Zuschlag, sodass nach ihrem Gebrauch als Untergrund von Straßenbau und Gebäuden wieder verwendet werden können. Weitere Infos bekommen Sie auf der Webseite der Marke ECOLABEL <http://www.ecolabel.eu>. Die Marke “ECOLABEL” wurde von Lea Ceramiche fuer die Artikel folgender Serien gewonnen: Tecnoquartz, Stonehenge, Basaltina Stone Project, Bioessenze, Midtown, Masterplan.

ESP

Ecolabel es un sistema de certificación medioambiental de producto, creado por la Comunidad Europea (Reglamento (CE) n° 66/2010), que permite a todos los consumidores adquirir mercancías ecológicamente compatibles, contribuyendo de manera concreta a la salvaguardia y a la mejora del ecosistema y, por consiguiente, de la calidad de vida. Todos los productos Ecolabel están marcados con una margarita. Esta etiqueta constituye un certificado de excelencia, al ser concedida sobre la base de un severo análisis del ciclo de vida (ACV). Para cada producto se tienen en cuenta todos los aspectos medioambientales en cada fase de producción, desde las materias primas hasta la eliminación: la calidad del aire y del agua, la protección de los suelos, la reducción de los residuos, el ahorro energético, la gestión de los recursos naturales, la protección de la capa de ozono y el impacto en la biodiversidad. Las baldosas de LEA CERAMICHE son materiales completamente inertes, y tras desecharlas, se pueden reciclar para ser utilizadas como fundación de carreteras y edificios. Mayor información disponible en nuestra página de internet, en la marca ECOLABEL <http://www.ecolabel.eu>. Lea Ceramiche ha obtenido la marca ECOLABEL por los productos de las series: Tecnoquartz, Stonehenge, Basaltina Stone Project, Bioessenze, Midtown, Masterplan.

Certificazione partner CasaClima

partner CasaClima certification

certification partner CasaClima

zertifikat partnerschaft CasaClima

certificación partner CasaClima

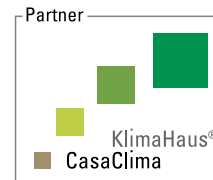

ITA

CasaClima, costruire con rispetto.

Lea Ceramiche è stata riconosciuta Partner CasaClima, dimostrando di soddisfare tutti i rigorosi requisiti necessari per questa certificazione. Il gres porcellanato Lea Ceramiche è ideale per progettare case a ridotto consumo energetico. CasaClima è un ente autonomo che da vent'anni promuove il certificato energetico per gli edifici. In questo modo diffonde la cultura dell'edilizia sostenibile, che significa costruire abitazioni di qualità, confortevoli e al tempo stesso rispettose dell'ambiente. La certificazione energetica riguarda sia le nuove costruzioni che gli immobili ristrutturati, e prende in considerazione tre fattori:

- efficienza energetica dell'involucro edilizio
- utilizzo di energie rinnovabili (es. pannelli solari)
- riduzione dell'impatto ambientale attraverso l'uso di materiali naturali

L'efficienza energetica dell'involucro edilizio viene misurata e classificata in riferimento al consumo di combustibile per il riscaldamento di un edificio in un anno:

classe ORO = fabbisogno energetico < 1 litro/mq/anno

classe A < 3 litri/mq/anno

classe B < 5 litri/mq/anno

classe C < 7 litri/mq/anno

La classificazione CasaClima PIÙ (applicabile alle classi ORO, A e B) viene riconosciuta agli edifici che utilizzano fonti energetiche rinnovabili e che vengono costruiti esclusivamente con materiali sostenibili per l'ambiente e la salute.

Le piastrelle Lea Ceramiche, che utilizzano materie prime naturali, non contengono sostanze sintetiche. Vengono prodotte con un ciclo produttivo certificato ISO 14001 ed EMAS e possono contribuire al conseguimento di questo traguardo.

Ecco gli ambiti in cui possono essere utilizzate per ottenere la certificazione CasaClima:

- Finitura di pavimenti e rivestimenti. È sconsigliato l'utilizzo di materiali sintetici come il PVC. Il gres porcellanato Lea Ceramiche offre prestazioni di sicurezza (resistenza al fuoco), pulibilità e durabilità superiori rispetto al legno.
- Impianti di riscaldamento a pavimento. Rispetto al legno, che non è un buon conduttore, il gres porcellanato Lea Ceramiche offre prestazioni di eccellenza, poiché favorisce l'ottimizzazione del sistema completo con temperature più basse dell'acqua e di conseguenza il risparmio energetico dell'intero impianto.
- Rivestimenti di facciate ventilate. In questi casi è indicato l'utilizzo del gres porcellanato Lea Ceramiche, per il suo design e la facilità di installazione; o di Slimtech, per la leggerezza e il grande formato. Rispetto ai materiali lapidei e metallici, inoltre, le performance che rendono ottimale la scelta dei prodotti Lea Ceramiche sono sicuramente la maggior resistenza agli agenti atmosferici, allo smog, agli agenti chimici, e le caratteristiche di durabilità nel tempo (resistenza all'invecchiamento, all'azione della luce e del gelo).
- Finitura di pannelli di tamponamento esterno per strutture e case prefabbricate.

Anche in questo caso Slimtech è una scelta idonea per le sue caratteristiche tecniche e grandi dimensioni.

ENG

CasaClima, building with respect.

Lea Ceramiche has been recognized as a CasaClima Partner, proving that it can satisfy the necessary requirements for this certification. Lea Ceramiche stoneware is ideal for designing houses with low energy consumption.

CasaClima is an autonomous agency that has for the last 20 years promoted energetic certification for buildings. In this way it promotes a culture of sustainable construction, which means building quality and comfortable housing that respect the environment. The energy certification deals with new constructions as well as restructuring, and takes into account three factors:

- energetic efficiency of the shell of the building
- use of renewable energy
- reduction of environmental impact through the use of natural materials

Energy efficiency of the shell is measured and classified referring to the combustion materials for the heating of the building annually:

Oro class = energy need < 1 liter/sqm/year

Class A < 3 liters/sqm/year

Class B < 5 liters/sqm/year

Class C < 7 liters/sqm/year

CasaClima Più classification (for ORO, A and B class) are for buildings that use renewable Energy sources and that are built exclusively using sustainable materials.

Lea Ceramiche tiles, that are made using natural raw materials, do not include synthetic products. These products are produced with a productive cycle that is ISO14001 and Emas certified, and contribute to reaching this thresholds.

Here are the cases in which Lea Ceramiche products can be used to obtain CasaClima certifications:

- Flooring and walling. It is not advised to use synthetic materials such as PVC.
- Lea Ceramiche products offer safety attributes (resistance to fire), ease of cleaning and durability superior to wood
- Floor warming systems. With respect to wood, that is not a good conductor, Lea Ceramiche stoneware offers excellent results. It helps optimize the complete system using lower temperatures for the water used in the heating process and therefore energy efficiency in the whole building
- Ventilated surfaces. In this case it is a great choice to use Lea Ceramiche stoneware, for its design characteristics and the easy of installation; or Slimtech, for its light weight and large formats. Compared to stone and metallic materials, the performances that make the choice of these products, by Lea Ceramiche, excellent are major resistance to atmospheric agents, smog, chemical agents, and the durability in time (resistance to ageing due to the effect of light and frost).
- External finish for prefabricated housing. Even in this case Slimtech is an ideal solution for its technical characteristics and its large formats.

FRA

CasaClima, construire avec respect.

Lea Ceramiche est désormais membre de CasaClima. En effet, la société a satisfait à tous les critères stricts posés par cette certification. Le grès cérame Lea Ceramiche est l'atout idéal pour construire des maisons à faible consommation d'énergie.

CasaClima est un organisme indépendant qui, depuis vingt ans, encourage la certification énergétique des bâtiments. Il divulgue ainsi la culture du bâtiment durable, c.-à-d. construire des maisons de qualité, à la fois confortables et respectueuses de l'environnement. La certification énergétique s'applique tant aux nouvelles constructions qu'aux restructurations. Trois facteurs sont examinés :

- efficacité énergétique du bardage
- utilisation d'énergies renouvelables
- réduction de l'impact sur l'environnement par application de matériaux naturels

L'efficacité énergétique du bardage est calculée et classée en fonction de la consommation d'énergie due au chauffage d'un bâtiment sur un an :

classe OR = besoin en énergie < 1 litre/m²/an

classe A < 3 litres/m²/an

classe B < 5 litres/m²/an

classe C < 7 litres/m²/an

Le classement CasaClima PLUS (applicable aux classes OR, A et B) englobe les bâtiments qui utilisent des énergies renouvelables et qui ne sont construits qu'avec des matériaux durables pour l'environnement et la santé.

Les carreaux Lea Ceramiche ne contiennent que des matières premières naturelles et, par conséquent, aucune substance synthétique. La production observe un cycle certifié ISO 14001 et EMAS. Ces produits peuvent donc contribuer à atteindre cet objectif.

Ci-après toutes les applications utiles pour obtenir la certification CasaClima :

- Finition des sols et des murs. Il est déconseillé d'appliquer des matériaux synthétiques comme le PVC. Le grès cérame Lea Ceramiche assure une sécurité (résistance au feu), une facilité de nettoyage et une durabilité meilleures que le bois.
- Systèmes de chauffage au sol. Par rapport au bois qui n'est pas un bon conducteur, le grès cérame Lea Ceramiche garantit une performance excellente, car il contribue à optimiser tout le système avec des températures d'eau plus basses et, par conséquent, à faire des plus grandes économies d'énergie.
- Revêtements des façades ventilées. Dans ce cas, le grès cérame Lea Ceramiche est recommandé pour son style et sa facilité de pose, ou Slimtech pour sa légèreté et son format maxi. De plus, par rapport aux pierres et aux métaux, les atouts en faveur des produits Lea sont certainement leur plus grande résistance aux agents atmosphériques, au smog et aux agents chimiques, ainsi que leur durabilité à long terme (résistance au vieillissement, à la lumière et au gel).
- Finition des murs de remplissage pour structures et maisons préfabriquées. Cette fois encore, Slimtech est parfait pour ses propriétés techniques et ses grandes dimensions.

Certificazione partner CasaClima

partner CasaClima certification
certification partner CasaClima
zertifikat partnerschaft CasaClima
certificación partner CasaClima

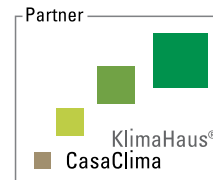

DEU

CasaClima, bauen mit Respekt.

Lea Ceramiche wurde als KlimaHaus-Partner anerkannt und beweist somit, alle strengen Kriterien, die für die Zertifizierung notwendig sind, zu erfüllen. Das Feinsteinzeug von Lea Ceramiche ist die ideale Lösung für die Planung von Energiesparhäusern. KlimaHaus besteht seit zwanzig Jahren als selbstständige Körperschaft und fördert den Energiepass für nachhaltige Gebäude. Auf diese Weise wird eine nachhaltige Baukultur verbreitet, die den Bau von qualitativ hochwertigen Gebäuden, die das Wohlbefinden steigern und gleichzeitig umweltschonend sind, ermöglicht.

Der Energiepass bezieht sich auf neue Bauten sowie renovierte Gebäude und berücksichtigt die drei folgenden Aspekte:

- Energieeffizienz des Gebäudes
- Einsatz erneuerbarer Energien
- Reduzierung der Umweltbelastung durch Verwendung von Naturmaterialien

Die Energieeffizienz der Gebäudehülle wird gemessen und klassifiziert gemäß des zu erwartenden Heizwärmebedarfs:

Klasse GOLD = Energiebedarf < 1 l/m²Jahr

Klasse A < 3 l/m²Jahr

Klasse B < 5 l/m²Jahr

Klasse C < 7 l/m² / Jahr

Die Auszeichnung CasaClima Plus (für die Klassen GOLD, A und B) wird an Wohngebäude vergeben, bei denen erneuerbare Energien verwendet und die ausschließlich mit umwelt- und gesundheitsverträglichen Baustoffen gebaut werden.

Die Fliesen von Lea Ceramiche, aus natürlichen Rohstoffen und ohne synthetische Substanzen hergestellt, tragen anhand des gemäß ISO 14001 und EMAS zertifizierten Produktionsverfahrens zur Erreichung dieses Ziels bei.

Hier sind die Bereiche, in denen sie eingesetzt werden können, um die KlimaHaus-Zertifizierung zu erhalten:

- Ausführung von Bodenbelägen und Verkleidungen. Es wird vom Einsatz synthetischer Materialien wie PVC abgeraten und das Feinsteinzeug von Lea Ceramiche bietet sichere Leistungen (Feuerbeständigkeit, Pflegeleichtigkeit und größere Langlebigkeit im Vergleich zu Holzprodukten).
- Fußbodenheizungssysteme: Im Vergleich zu Holz, das kein guter Leiter ist, ist Feinsteinzeug höchst leistungsstark, da es das Gesamtsystem durch geringere Wassertemperaturen optimiert und folglich zu einer Energieersparnis der Gesamtanlage führt.
- Wandverkleidungen hinterlüfteter Fassaden: Für diese Fälle wird das Feinsteinzeug von Lea Ceramiche wegen seines Designs und der einfachen Verlegung oder die Slimtech-Fliesen, die sich durch Leichtigkeit und Großformat auszeichnen, empfohlen. Gegenüber Stein oder Metall eignen sich die Produkte von Lea optimal, da sie äußerst wetter-, chemikalien- und smogbeständig sind und bestechen durch ihre Langlebigkeit (Alterungsbeständigkeit, Farbestabilität sowie Frostbeständigkeit).
- Oberflächenausführung für externe Ausfachungsplatten für Fertigstrukturen und-häuser.

Slimtech ist in diesem Fall ebenfalls die erste Wahl aufgrund der technischen Produkteigenschaften und Größen.

ESP

CasaClima, construir con respeto.

Lea Ceramiche ha recibido el reconocimiento de Socio CasaClima, demostrando cumplir todos los severos requisitos necesarios para esta certificación. El gres porcelánico de Lea Ceramiche es ideal para diseñar casas con un reducido consumo energético. CasaClima es un organismo autónomo que, desde hace veinte años, promueve el certificado energético para los edificios. De este modo, difunde la cultura de la construcción sostenible, que significa construir viviendas de calidad, confortables y, al mismo tiempo, respetuosas con el medio ambiente. Dicha certificación se refiere tanto a las nuevas construcciones como a los inmuebles remodelados, y tiene en cuenta tres factores:

- eficiencia energética de la envoltura de la construcción
- utilización de energías renovables (por ej. paneles solares)
- reducción del impacto medioambiental mediante el uso de materiales naturales

La eficiencia energética de la envoltura de la construcción se mide y se clasifica sobre la base del consumo de combustible para la calefacción de un edificio en un año:

clase ORO = demanda energética < 1 litro/m²/año

clase A < 3 litros/m²/año

clase B < 5 litros/m²/año

clase C < 7 litros/m²/año

La clasificación CasaClima PIÙ (aplicable a las clases ORO, A y B) se reconoce a aquellos edificios que utilizan fuentes energéticas renovables y que se construyen exclusivamente con materiales sostenibles para el medio ambiente y la salud.

Los azulejos de Lea Ceramiche, que utilizan materias primas naturales, no contienen sustancias sintéticas. Se fabrican con un ciclo de producción certificado según ISO 14001 y EMAS y pueden contribuir a la consecución de este objetivo.

He aquí los ámbitos en los que se pueden utilizar para obtener la certificación CasaClima:

- Acabado de pavimentos y revestimientos. Se desaconseja la utilización de materiales sintéticos como el PVC. El gres porcelánico de Lea Ceramiche ofrece prestaciones de seguridad (resistencia al fuego), facilidad de limpieza y durabilidad superiores a las de la madera.
- Instalaciones de calefacción en el pavimento. El gres porcelánico de Lea Ceramiche ofrece, respecto a la madera, que no es un buen conductor, excelentes prestaciones, pues favorece la optimización del sistema completo con temperaturas más bajas del agua y, por consiguiente, el ahorro energético de toda la instalación.
- Revestimientos de fachadas ventiladas. En estos casos, está indicado el empleo del gres porcelánico de Lea Ceramiche, por su diseño y facilidad de instalación; o de Slimtech, por su ligereza y gran formato. Además, respecto a los materiales lapídeos y metálicos, las prestaciones que hacen que la elección de los productos Lea sea óptima son seguramente su mayor resistencia a los agentes atmosféricos, al smog, a los agentes químicos, así como sus características de durabilidad en el tiempo (resistencia al envejecimiento, a la acción de la luz y la helada).
- Acabado de paneles de relleno exterior para estructuras y casas prefabricadas. También en este caso Slimtech es una elección idónea por sus características técnicas y grandes dimensiones.

	KlimaHaus-ZERTIFIKAT Geprüfte Qualität für energieeffizientes und nachhaltiges Bauen Qualità controllata per l'edilizia sostenibile ed efficienza energetica CERTIFICATO CasaClima
	Nach sorgfältiger Überprüfung erteilt die KlimaHaus Agentur an Dopo un esame accurato l'Agenzia CasaClima rilascia alla PANARIA Group S.p.A. I-41034 Finale Emilia (MO), Via Panaria Bassa, 22/a die Auszeichnung / il titolo di Zertifizierter KlimaHaus Partner Partner certificato CasaClima
	Zertifikat / Certificato Nr. 0078 / 2 Erstausstellung: / Data del rilascio: 20.04.2009 Erneuerung: / Emissione corrente: 06.12.2012 Gültig bis: / Valido fino al: 05.12.2014
	Bozen / Bolzano, 06.12.2012 KlimaHaus Agentur GmbH / Agenzia CasaClima srl Ulrich Santa Direktor / Direttore

Certificazione 40% materiale riciclato

certified 40% recycled material

certifié 40% de matériel recyclé

zertifizierung 40% recyceltes material

certificación 40% material reciclado

LEA CERAMICHE

40%



RECYCLED CERAMIC CONTENT
[PRECONSUMER MATERIALS]
LEED COMPLIANT CREDIT MR 4

ISTITUTO DI CERTIFICAZIONE DELLA QUALITÀ

CERTIFICATO / CERTIFICATE

N. P1172

SI CERTIFICA CHE IL PRODOTTO / WE HEREBY CERTIFY THAT THE PRODUCT

PIASTRELLE DI CERAMICA REALIZZATE CON MATERIALE RICICLATO
CERAMIC TILES PRODUCED WITH RECYCLED MATERIALS
(dettagli negli allegati / details in annexes 1-2-3-4-5-6)

DELL'ORGANIZZAZIONE / OF THE ORGANIZATION

PANARIAGROUP INDUSTRIE CERAMICHE S.p.A.
41034 FINALE EMILIA (MO) – Via Panaria Bassa 22/A

E' CONFORME A / COMPLETS WITH

DT 55 ED 01 010409

"DOCUMENTO TECNICO PER LA CERTIFICAZIONE DI PRODOTTO RELATIVA A PRODOTTI PER L'EDILIZIA CON PERCENTUALE INDICATA DI MATERIALE RICICLATO: PIASTRELLE DI CERAMICA E SEMILAVORATI DA UTILIZZARSI PER LA LORO PRODUZIONE"

"TECHNICAL DOCUMENT FOR PRODUCT CERTIFICATION OF CONSTRUCTION PRODUCTS WITH THE SPECIFIED PERCENTAGE OF RECYCLED MATERIAL CERAMIC TILES AND SEMI-FINISHED ITEMS FOR THE PRODUCTION THEREOF"

CERTIFICAZIONE "SYSTEM 6" SECONDO ISO/IEC GUIDE 47:2004

Il presente certificato non è da ritenersi valido se non accompagnato dai relativi allegati
This certificate is not valid without the relative Annexes

IL PRESENTE CERTIFICATO È SOGGETTO AL RISCHIO DI INQUADRAMENTO PER LA CERTIFICAZIONE DI CONFORMITÀ DI PRODOTTO
THIS CERTIFICATE IS BOUND TO FAILURE OF THE REGULATIONS APPLYING TO PRODUCT CERTIFICATION

PRIMA EMISSIONE: **28/07/2008**
FIRST ISSUE

EMMISSIONE CORRENTE: **11/07/2011**
CURRENT ISSUE

DATA DI SCADENZA: **27/07/2015**
EXPIRY DATE

CERTIQUALITY S.p.A.

CORIQUALITY S.p.A. ISTITUTO DI CERTIFICAZIONE DELLA QUALITÀ
Via Carloso Giuliano 4 - 20123 Milano - tel. 02 8669171 - fax 02 8645103 - certiquality@certiquality.it - www.certiquality.it

ISTITUTO DI CERTIFICAZIONE DELLA QUALITÀ

ALLEGATO 2 AL CERTIFICATO / ENCLOSURE TO CERTIFICATE N. P1172

SERIE DI PRODOTTO PIASTRELLE IN CERAMICA	STABILIMENTO PRODUCTION SITE	MATERIALE RICICLATO RECYCLED MATERIAL	
		% PRE-CONSUMO PRE-CONSUMER	% POST-CONSUMO POST-CONSUMER
TECNOQUART	Toano	2-40%	0
STONEHANGE	Toano	2-40%	0
RAIN FOREST	Finale Emilia	2-40%	0
RESOLUTION STONE PROJECT	Toano	2-40%	0
CRISTALLO	Toano	2-40%	0
MARBLEPLAN	Toano	2-40%	0
MILTON	Toano	2-40%	0
SPARK	Toano	2-40%	0
BOSSALETTO	Toano	2-40%	0
MAKO	Toano	2-40%	0
CERAMOD	Finale Emilia	2-40%	0
SALERS	Toano	2-40%	0
BLUE MOUNTAIN	Toano	2-40%	0
NAOS	Toano	2-40%	0
DAI QUARTZ	Toano	2-40%	0
ARABIA	Toano	2-40%	0
METROPOLIS	Toano	2-40%	0
BO FPM	Toano	2-40%	0
OLIGI	Toano	2-40%	0
BLACK	Finale Emilia	2-40%	0

Prodotto presso gli stabilimenti di Finale Emilia e Toano / Produced in Finale Emilia and Toano production sites.

IL PRESENTE ALLEGATO NON È DA RITENERSI VALIDO SE NON ACCOMPAGNATO DAL RELATIVO CERTIFICATO.
THIS ANNEX IS NOT VALID WITHOUT THE RELEVANT CERTIFICATE.

PRIMA EMISSIONE: **28/07/2008**
FIRST ISSUE

EMMISSIONE CORRENTE: **11/07/2011**
CURRENT ISSUE

DATA DI SCADENZA: **27/07/2015**
EXPIRY DATE

CERTIQUALITY S.p.A.

CORIQUALITY S.p.A. ISTITUTO DI CERTIFICAZIONE DELLA QUALITÀ
Via Carloso Giuliano 4 - 20123 Milano - tel. 02 8669171 - fax 02 8645103 - certiquality@certiquality.it - www.certiquality.it

Certificazione del sistema qualità aziendale

company quality control certification

certifications du système de qualité d'entreprise

qualitätsbescheinigung der firma

certificación del sistema de calidad empresarial



ISTITUTO DI CERTIFICAZIONE DELLA QUALITÀ
www.certiquality.it

ALLEGATO 5 AL CERTIFICATO N° 6744
ANNEX 5 TO CERTIFICATE N°

PANARIAGROUP INDUSTRIE CERAMICHE S.p.A.

DIVISIONE LEA CERAMICHE

LISTA UNITÀ OPERATIVE/OPERATIVE UNITS LIST

I - 41042 FIORANO MODENESE (MO) - VIA CAMEZZO 21

Vendita di materiale ceramico per pavimenti e rivestimenti.
Sale of ceramic materials for flooring and covering.

IL PRESENTE ALLEGATO NON È DA RITENERSI VALIDO SE NON ACCOMPAGNATO DAL RELATIVO CERTIFICATO
THIS ANNEX IS NOT VALID WITHOUT THE RELEVANT CERTIFICATE

PRIMA EMISSIONE FIRST ISSUE	23/09/2003
EMISSIONE CORRENTE CURRENT ISSUE	18/12/2012
DATA DI SCADENZA EXPIRY DATE	17/12/2015

CERTIQUALITY S.p.A. - IL DIRETTORE GENERALE

CISQ is a member of

www.ionet-certification.com

IONet, the association of the world's first class certification bodies, is the largest provider of management System Certification in the world. IONet is composed of more than 20 bodies and counts over 150 subsidiaries all over the globe.

CISQ è la Federazione Italiana di Organismi di Certificazione dei sistemi di gestione aziendale.

CISQ is the Italian Federation of management system Certification Bodies.

CONFEDERAZIONE ITALIANA
DEI SISTEMI DI GESTIONE

MOD. 01/008 A
DQA N° 001 D
SGB N° 002 F
PST N° 008 I

PER INFORMAZIONI SULLA VERITÀ DEL CERTIFICATO, VISITATE IL SITO www.certiquality.it

For information concerning the validity of the certificate, you can visit the site www.certiquality.it

Attestato degli Accordi di Mutual Riconoscimento SA, SA1 e SA2
Signature of SA, SA1 and SA2 Mutual Recognition Agreements

La validità del presente certificato è subordinata a sorveglianza periodica annuale ed al riesame completo dal Sistema di Gestione con periodicità triennale.

The validity of this certificate depends on annual audit and on a complete review every three years of the Management System.

WWW.CISQ.ORG

Certificazione del sistema qualità dei siti produttivi

company quality control certification for production sites

certification du système qualité des sites productifs

qualitätsbescheinigung des systems der produktionsstätte

certificación del sistema de calidad de los lugares de producción





ISTITUTO DI CERTIFICAZIONE DELLA QUALITÀ
www.certiquality.it

CISQ is a member of



www.ionet-certification.com

IONet, the association of the world's first class certification bodies, is the largest provider of management System Certification in the world. IONet is composed of more than 30 bodies and covers over 150 subsidiaries all over the globe.

CERTIFICATO n. **6744**
CERTIFICATE No

SI CERTIFICA CHE L'ORGANIZZAZIONE
WE ABBRSEY CERTIFY THAT THE ORGANIZATION

PANARIAGROUP INDUSTRIE CERAMICHE S.p.A
I - 41034 FINALE EMILIA (MO) - VIA PANARIA BASSA 22/A

NELLE SEGUENTI UNITÀ OPERATIVE / IN THE FOLLOWING OPERATIVE UNITS

I - 41034 FINALE EMILIA (MO) - VIA PANARIA BASSA 22/A
I - 41042 FIORANO MODENESE (MO) - VIA GAMEZZO 21
I - 42010 TOANO (RE) - ZONA INDUSTRIALE FORA DI CAVOLA
I - 41049 SASSUOLO (MO) - VIA EMILIA ROMAGNA 31
(dettagli negli allegati / details in annexo 1-2-3-4-5)

HA ATTUATO E MANTIENE UN SISTEMA DI GESTIONE QUALITÀ CHE È CONFORME ALLA NORMA
HAS IMPLEMENTED AND MAINTAINS A QUALITY MANAGEMENT SYSTEM WHICH COMPLIES WITH THE FOLLOWING STANDARD:

UNI EN ISO 9001:2008 SETTORE CODE **EA 15**

PER LE SEGUENTI ATTIVITÀ / FOR THE FOLLOWING ACTIVITIES

Ricerca e sviluppo, produzione e vendita di materiale ceramico per pavimenti e rivestimenti.
Research and development, production and sale of ceramic materials for flooring and covering.

REFERIRSI AL MANUALE DI GESTIONE QUALITÀ PER L'APPLICABILITÀ DEI REQUISITI DELLA NORMA
REFER TO MANAGEMENT SYSTEM MANUAL FOR DETAILS OF APPLICATION TO STANDARD REQUIREMENTS

IL PRESENTE CERTIFICATO È SOGGETTO AL RISPETTO DEL REGOLAMENTO PER LA CERTIFICAZIONE DEI SISTEMI DI GESTIONE
THE USE AND THE VALIDITY OF THE CERTIFICATE SHALL SATISFY THE REQUIREMENTS OF THE RULES FOR THE CERTIFICATION OF MANAGEMENT SYSTEMS

IL PRESENTE CERTIFICATO NON È DA RITENERSI VALIDO SE NON ACCOMPAGNATO DAI RELATIVI ALLEGATI
THIS CERTIFICATE IS NOT VALID WITHOUT THE RELEVANT ANNEXES

PRIMA EMISSIONE FIRST ISSUE	24/09/2003
EMISSIONE CORRENTE CURRENT ISSUE	18/12/2012
DATA DI SCADENZA EXPIRY DATE	17/12/2015



CERTIQUALITY S.p.A. - IL DIRETTORE GENERALE



500 N° 009 A
500 N° 001 G
500 N° 003 F
500 N° 004 L

500 N° 008 B
500 N° 001 H
500 N° 007 G
500 N° 005 R

Members degli Accordi di Mutual Recognition EA, IAF e ILAC
Signatory of EA, IAF and ILAC Mutual Recognition Agreements

Per informazioni sulla validità del certificato, visitate il sito
www.certiquality.it

For information concerning the validity of the certificate, you can visit the site
www.certiquality.it

La validità del presente certificato è subordinata a sorveglianza periodica annuale ed al rinnovo annuale del Sistema di Gestione con periodicità triennale.

The validity of this certificate depends on annual audit and on a complete review every three years of the Management System.

CISQ è la Federazione Italiana di Organismi di Certificazione dei sistemi di gestione aziendale.

CISQ is the Italian Federation of Management System Certification Bodies.



www.cisq.org

Certificazione del sistema ambientale dei siti produttivi

environmental certification for production sites

certification du système environnemental des sites productifs

zertifizierung des umweltsystems der produktionstätte

certificación del sistema de calidad de los lugares de producción



ISTITUTO DI CERTIFICAZIONE DELLA QUALITÀ
www.certiquality.it

CISQ is a member of

www.ionet-certification.com

IONet, the association of the world's first class certification bodies, is the largest provider of management System Certification in the world. IONet is composed of more than 30 bodies and covers over 150 substances all over the globe.

CERTIFICATO n. **6745**
CERTIFICATE No

SI CERTIFICA CHE L'ORGANIZZAZIONE
WE HEREBY CERTIFY THAT THE ORGANIZATION

PANARIAGROUP INDUSTRIE CERAMICHE S.p.A
I - 41034 FINALE EMILIA (MO) - VIA PANARIA BASSA 22/A

NELLE SEGUENTI UNITÀ OPERATIVE / IN THE FOLLOWING OPERATIVE UNITS

I - 41034 FINALE EMILIA (MO) - VIA PANARIA BASSA 22/A
I - 41042 FIORANO MODENESE (MO) - VIA CAMEZZO 21
I - 42010 TOANO (RE) - ZONA INDUSTRIALE FORA DI CAVOLA

HA ATTUATO E MANTIENE UN SISTEMA DI GESTIONE AMBIENTALE CHE È CONFORME ALLA NORMA
HAS IMPLEMENTED AND MAINTAINS AN ENVIRONMENTAL MANAGEMENT SYSTEM WHICH COMPLIES WITH THE FOLLOWING STANDARD

UNI EN ISO 14001:2004 SETTORE **EA 15**
SECTOR

PER LE SEGUENTI ATTIVITÀ / FOR THE FOLLOWING ACTIVITIES

Ricerca e sviluppo, produzione e vendita di materiale ceramico per pavimenti e rivestimenti.
Research and development, production and sale of ceramic materials for flooring and covering.

CERTIFICAZIONE RILASCIATA IN CONFORMITÀ: IN REGOLAMENTO TECNICO 8706
IL PRESENTE CERTIFICATO È SOGGETTO AL RISPETTO DEL REGOLAMENTO PER LA CERTIFICAZIONE DEI SISTEMI DI GESTIONE!
THE USE AND THE VALIDITY OF THE CERTIFICATE SHALL SATISFY THE REQUIREMENTS OF THE RULES FOR THE CERTIFICATION OF MANAGEMENT SYSTEMS

PRIMA EMISSIONE FIRST ISSUE	24/09/2003
EMISSIONE CORRENTE CURRENT ISSUE	18/12/2012
DATA DI SCADENZA EXPIRY DATE	17/12/2015

CERTIQUALITY S.r.l. - IL DIRETTORE GENERALE

CONFORME ALLE
ISO 9001:2008
ISO 14001:2004
ISO 9001:2015
ISO 14001:2015

Member degli Accordi di Mutuo Riconoscimento EA, IAF e ILAC
Signatory of EA, IAF and ILAC Mutual Recognition Agreements

Per informazioni sulla validità del certificato, visitate il sito
www.certiquality.it

For information concerning the validity of the certificate, you can visit the site
www.certiquality.it

La validità del presente certificato è subordinata a sorveglianza periodica annuale ed al rispetto completo del Sistema di Gestione con periodicità triennale.

The validity of this certificate depends on annual audit and on a complete review every three years of the Management System.

CISQ è la Federazione Italiana di Organismi di Certificazione dei sistemi di gestione aziendali.

CISQ is the Italian Federation of management system Certification Bodies.

www.cisq.com

Certificazione ambientale EMAS dei siti produttivi

environmental certification EMAS for production sites

certification environnemental EMAS des sites productifs

EMAS-zertifizierung (umweltmanagement und umweltbetriebsprüfung) der produktionsstätte

certificación medioambiental EMAS de los lugares de producción

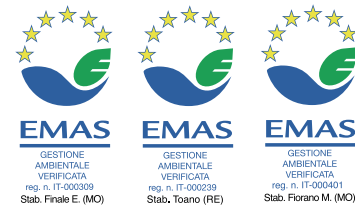

ITA

Il regolamento (CE) n. 1221/2009 del Parlamento Europeo e del Consiglio, introduce il sistema comunitario di ecogestione ed audit Emas per le organizzazioni. Lea Ceramiche beneficia della Registrazione EMAS per il sito produttivo di Toano (RE), (Numero Registrazione I-000239 in data 30 Settembre 2004), per il sito produttivo di Finale Emilia (MO), (Numero Registrazione I-000309 in data 14 Aprile 2005) e per il sito produttivo di Fiorano Modenese (MO), (Numero Registrazione I-000401 in data 15 Dicembre 2005). Questa registrazione riveste una grande importanza, perché impone la creazione di un vero Sistema di gestione Ambientale, basato sul continuo miglioramento delle proprie prestazioni ambientali. Il sistema si basa sulla creazione di un rapporto di collaborazione e fiducia con le istituzioni del territorio (Enti, Autorità, Associazioni, Rappresentanze Sindacali, Scuole, Stampa) e con il pubblico, ed è prevista la partecipazione attiva di tutti i dipendenti. La Dichiarazione Ambientale è il documento finale che descrive gli aspetti ambientali e di sicurezza sul lavoro, le prestazioni ambientali del sito e gli obiettivi ambientali che l'Azienda si impone di raggiungere nell'ottica del miglioramento continuo. La dichiarazione è convalidata da un Verificatore Ambientale Accreditato, a seguito verifiche ispettive (audit) eseguite in stabilimento, ed è disponibile sul sito www.ceramichelea.it. Lea Ceramiche, attenta alle problematiche a salvaguardia dell'ambiente, produce le proprie piastrelle presso stabilimenti Panariagroup che hanno ottenuto le due Certificazioni Ambientali ISO 14001 e Registrazione EMAS, a testimonianza della massima attenzione e sensibilità del management alle questioni etiche, ambientali e di sicurezza.

ENG

EC Regulation no. 1221/2009 of the European Parliament and of the Council introduced the EMAS eco-management and audit scheme for organisations. Lea Ceramiche benefits from Registration EMAS for the Toano (RE) production site (Number Registration I – 000239 on date 30th September 2004), for the Finale Emilia (MO) production site (Number Registration I – 000309 on date 14th April 2005) and for the Fiorano Modenese (MO) production site (Number Registration I – 000401 on date 15th December 2005). This registration is of major importance, since it requires a proper Environmental Management System to be created, based on the continual improvement of environmental performance within organisations. The scheme is based on the creation of an open dialogue with local institutions (Agencies, Authorities, Associations, Trade Union Representatives, Schools, Press) and with the public, and it is expected that all employees will play an active part. The Environmental Statement is the end document that describes the environmental and safety aspects in the workplace, the environmental performance of the site and the environmental targets that the Company sets itself within the framework of continual improvement. The statement is validated by an Accredited Environmental Verifier, following audits carried out in the plant, it's also available on the website www.ceramichelea.it. Lea Ceramiche, caring for environment protection, produces its tiles in its plants Panariagroup, that obtained two environmental certifications ISO 14001 and the Registration EMAS. This proves the great attention and sensitiveness of our management towards ethic, environmental, and safety issues.

FRA

Le règlement (CE) n° 1221/2009 du Parlement Européen et du Conseil introduit le système communautaire de management environnemental et d'audit (EMAS) pour les organisations. Lea Ceramiche bénéficie de l'accréditation EMAS pour le site de Toano (RE) (Numero Enregistrement I – 000239 en date 30 Septembre 2004), pour le site de Finale Emilia (MO) (Numero Enregistrement I – 000309 en date 14 Avril 2005) et pour le site de Fiorano Modenese (MO) (Numero Enregistrement I – 000401 en date 15 Décembre 2005). Le système repose sur la création d'un rapport de collaboration et de confiance avec les institutions du territoire (Institutions, Pouvoirs publics, Associations, Représentations syndicales, Écoles, Presses) et avec le public. Il est prévu que tous les employés participeront activement à ce programme. La Déclaration environnementale constitue le document final décrivant les éléments en matière d'environnement et de sécurité sur le lieu de travail, les efforts effectués par le site pour l'environnement et les objectifs que l'entreprise s'est fixés dans le cadre de cette amélioration perpétuelle. La déclaration a été validée par un Contrôleur officiel suite aux inspections (audit) effectuées et est disponible sur le site www.ceramichelea.it. Lea Ceramiche, attentive aux problématiques à sauvegarde de l'environnement, produit ses carreaux dans les établissements Panariagroup qui ont obtenus les deux Certifications pour l'environnement ISO 14001 et Accréditation EMAS, à témoignage de la plus grande attention et de la sensibilité de la part de la direction en ce qui concerne les questions éthiques, environnementales, de sécurité et de qualité.

DEU

Die Verordnung (EG) 1221/2009 des Europäischen Parlaments und des Rats führt ein Gemeinschaftssystem für das Umweltmanagement und die Umweltbetriebsprüfung (EMAS) für Organisationen ein. Lea Ceramiche profitiert vom EMAS – Registrierung für die Produktionsstätte Toano (RE) (Registrationsnummer I – 000239 vom 30. September 2004), für die Produktionsstätte Finale Emilia (MO) (Registrationsnummer I – 000309 vom 14. April 2005) und für die Produktionsstätte Fiorano Modenese (MO) (Registrationsnummer I – 000401 vom 15. Dezember 2005). Diese Registrierung hat eine große Bedeutung, da sie die Schaffung eines wahren Umweltmanagement-systems auf der Grundlage der kontinuierlichen Verbesserung der Effizienz des Umweltcontrollings impliziert. Das System basiert auf dem Aufbau einer kooperativen und von gegenseitigem Vertrauen geprägten Beziehung mit den territorialen Institutionen (öffentlichen Einrichtungen, Behörden, Verbänden, gewerkschaftlichen Vertretungen, Schulen, Presse) und der Öffentlichkeit. Des Weiteren ist die aktive Einbeziehung des gesamten Personals vorgesehen. Die Umweltschutzklärung ist das endgültige Dokument, in dem die Aspekte zum Umweltschutz und zur Sicherheit am Arbeitsplatz, die Initiativen zum Schutz der Umwelt an diesem Standort sowie die Ziele beschrieben werden, die das Unternehmen im Rahmen des kontinuierlichen Verbesserungsprozesses erreichen will. Die Erklärung wird von einem zugelassenen Umweltgutachter nach vor Ort durchgeführten Inspektionen (Audits) genehmigt, ist verfügbar auf der Website www.ceramichelea.it. Lea Ceramiche, ein Werk was grossen Wert auf Umweltschutz legt, produziert seine Fliesen in allen Werken der Panariagroup, die diese beide Umweltzertifikate ISO 14001 und die EMAS Registrierung erhalten haben, was das große Engagement und die Sensibilität des Unternehmens in bezug auf Ethik, Umweltschutz, Sicherheit und Qualität unter Beweis stellt.

ESP

El reglamento (CE) n. 1221/2009 del Parlamento y el Consejo europeos introduce el sistema comunitario de ecogestión y auditoría medioambientales EMAS para empresas. Lea Ceramiche se beneficia del Registro EMAS para su lugar de producción de Toano (provincia de Reggio Emilia), (número de registro I-000239 con fecha 30 de septiembre de 2004), para su lugar de producción Finale Emilia (provincia de Módena), (número de registro I-000309 con fecha 14 de abril de 2005) y para su lugar de producción Fiorano Modenese (provincia de Módena) (número de registro I-000401 con fecha 15 de diciembre de 2005). Este registro reviste de gran importancia, puesto que impone la creación de una auténtico sistema de gestión medioambiental basado en la continua mejora de las prestaciones ambientales. El sistema se basa en el establecimiento de una relación colaboradora y de confianza con las instituciones del territorio (entes, autoridades, asociaciones, representantes sindicales, escuelas y prensa) y con el público en general. Asimismo cuenta con la participación activa de todos los empleados. La Declaración Medioambiental es el documento final que describe los aspectos medioambientales y de seguridad en el trabajo, las prestaciones medioambientales del lugar y los objetivos medioambientales que la empresa debe alcanzar bajo la óptica de una mejora continua. Esta declaración se corrobora por un Verificador Ambiental Acreditado, seguida de inspecciones de comprobación (auditorías) llevadas a cabo en la fábrica y disponibles en la página Web www.ceramichelea.it. Lea Ceramiche, concienciada con las problemáticas para proteger nuestro entorno, produce sus propias baldosas en las fábricas Panariagroup, las cuales han obtenido las dos Certificaciones Ambientales ISO 14001 y el Registro EMAS, ratificando su atención y sensibilidad en la gestión de cuestiones éticas, medioambientales y de seguridad.

Lea Ceramiche socio del Green Building Council Italia

Lea Ceramiche is a member of the green building council italia

Lea Ceramiche est membre du green building council italia

Lea Ceramiche ist mitgesellschafter des green building councils italien

Lea Ceramiche es socio del green building council italia



ITA

Green Building Council Italia: per una nuova cultura edilizia.

Lea Ceramiche, tramite la holding Panariagroup Industrie Ceramiche S.p.A., è socio ordinario del Green Building Council Italia, un'associazione volontaria di imprese, enti e strutture che si pone l'obiettivo di:

- favorire la diffusione di una cultura dell'edilizia sostenibile
- sensibilizzare opinione pubblica e istituzioni sull'impatto che le modalità di progettazione e costruzione degli edifici hanno sulla qualità della vita
- fornire parametri di riferimento chiari agli operatori del settore e linee guida per ingegneri, architetti, professionisti

L'associazione promuove l'introduzione in Italia del sistema di certificazione indipendente LEED, in modo tale che i "green buildings" (edifici a basso impatto ambientale) divengano consuetudine e siano accettati come fattore radicato nella società.

ENG

Green Building Council Italia: for a new culture in construction.

Lea Ceramiche, through Panariagroup Industrie Ceramiche S.p.A. holding, is an ordinary member of the Green Building Council Italia, a voluntary association of companies, authorities and organizations that aim to:

- favor the diffusion of a sustainable construction culture
- make the public aware of the impact that design and construction of buildings have on the quality of life
- supply clear references to operators of the market and guidelines for engineers, architects and professionals

The association promotes the introduction in Italy of an independent LEED certification method, in such a way that "green buildings" (buildings with low environmental impact) become an ingrained value in society.

FRA

Green Building Council Italia: pour une nouvelle culture du bâtiment.

Par l'intermédiaire de la holding Panariagroup Industrie Ceramiche S.p.A., Lea Ceramiche est membre ordinaire du Green Building Council Italia, une association volontaire d'entreprises, d'organismes et de structures avec l'objectif de:

- divulguer la culture du bâtiment durable
- sensibiliser l'opinion publique et les institutions à l'impact de la conception et de la construction sur la qualité de vie
- donner des repères précis aux opérateurs du secteur et des directives aux ingénieurs, aux architectes et aux professionnels

L'association introduit en Italie le système de certification indépendant LEED pour promouvoir les green buildings (bâtiments à faible impact sur l'environnement).

DEU

Green Building Council Italia: Für eine neue Baukultur.

Lea Ceramiche ist durch die Holdinggesellschaft Panariagroup Industrie Ceramiche S.p.A. ordentliches Mitglied von Green Building Council Italia. Es handelt sich dabei um einen ehrenamtlichen Verband von Unternehmen, Einrichtungen und Anlagen, mit den folgenden Zielen:

- Verbreitung einer nachhaltigen Baukultur
- Sensibilisierung der öffentlichen Meinung und der Institutionen in Hinblick auf den Einfluß, den Planungs- und Baumodalitäten auf die Lebensqualität haben
- Klare Richtparameter für die in der Branche tätigen Unternehmen sowie Richtlinien für Ingenieure, Architekten und Fachleute zu liefern

Dieser Verband führt das System von unabhängiger Bestätigung LEED in Italien ein, um die so genannten "Green Buildings" – d. h. umweltschonende und nachhaltige Bauwerke – zu verbreiten.

ESP

Green Building Council Italia: para una nueva cultura de la construcción.

Lea Ceramiche, por medio de la sociedad holding Panariagroup Industrie Ceramiche S.p.A., es socio ordinario del Green Building Council Italia, una asociación voluntaria de empresas, entidades y estructuras con los siguientes objetivos:

- favorecer la difusión de una cultura de la construcción sostenible
- sensibilizar a la opinión pública y a las instituciones sobre el impacto que las modalidades de diseño y construcción de los edificios tienen en la calidad de vida
- proporcionar parámetros claros de referencia a los operadores del sector y directrices para ingenieros, arquitectos y profesionales

La asociación promueve la introducción en Italia del sistema de certificación independiente LEED, de manera que los green buildings (edificios de bajo impacto medioambiental) se conviertan en algo habitual y sean aceptados como un factor arraigado en la sociedad.

Lea Ceramiche socio dell'U.S. Green Building Council

Lea Ceramiche is a member of the U.S. green building council

Lea Ceramiche est membre du U.S. green building council

Lea Ceramiche ist mitgesellschafter des U.S. green building councils

Lea Ceramiche es socio del U.S. green building council



ITA

LEED: una pagella per l'ambiente.

Lea Ceramiche, tramite la holding Panariagroup Industrie Ceramiche S.p.A., è membro dell' U.S. Green Building Council, organizzazione degli Stati Uniti che promuove la realizzazione di edifici ed opere nel rispetto dell'ambiente, della salute e del benessere delle persone che ci vivono e lavorano. L'U.S. GBC ha elaborato uno standard chiamato LEED (Leadership in Energy and Environmental Design): è un sistema di parametri per l'edilizia sostenibile, che indica l'efficienza ambientale ed energetica di un edificio.

Si tratta di un sistema di rating per lo sviluppo di edifici verdi. Il LEED attribuisce dei crediti per ciascuno dei requisiti di sostenibilità. Dalla somma dei crediti deriva il livello di certificazione ottenuto per l'edificio. I prodotti Lea Ceramiche contribuiscono ad aumentare il punteggio LEED in diverse categorie.

ENG

LEED: a marking system for the environment.

Lea Ceramiche, through Panariagroup Industrie Ceramiche S.p.A. holding, is a member of the U.S. Green Building Council, an organization that promotes buildings that are environmentally responsible, profitable and healthy places to live and work in. The U.S. GBC has created a standard called LEED (Leadership in Energy and Environmental Design): it is a system of parameters for sustainable construction, that indicates the environmental and energy efficiency of the building. Lea Ceramiche products contribute to increasing the LEED points in several categories.

FRA

LEED: un bulletin pour l'environnement.

Lea Ceramiche est membre du U.S. Green Building Council, association américaine qui incite à la réalisation de bâtiments et d'ouvrages dans le respect de l'environnement, de la santé et du bien-être des personnes.

Le U.S. GBC a créé un référentiel appelé LEED (Leadership in Energy and Environmental Design): un système de facteurs pour la construction durable, qui calcule l'efficacité environnementale et énergétique d'un bâtiment. Il s'agit d'un système d'évaluation qui vise au développement de bâtiments "verts". Le référentiel LEED donne des points pour chaque critère de développement durable. Le total des points détermine le niveau de certification du bâtiment. Les produits Lea Ceramiche augmentent le score LEED dans plusieurs catégories.

DEU

LEED: Ein Umweltzeugnis.

Lea Ceramiche ist durch die Holdinggesellschaft Panariagroup Industrie Ceramiche S.p.A. ordentliches Mitglied des Amerikanischen Green Building Council, einer Organisation, die sich für den Bau von umweltschonenden Gebäuden und Bauwerken für das menschliche Wohlbefinden, engagiert. Die amerikanische Firma U.S. GBC hat einen sogenannten LEED-Standard (Leadership in Energy and Environmental Design) ausgearbeitet: ein System an Parametern für nachhaltige Bauwerke, die in einem Ratingsystem eingeteilt sind, mit dem Ziel die Umwelt- und Energieeffizienz eines Gebäudes nachzuweisen.

LEED verleiht demnach Punkte für alle Nachhaltigkeitskriterien. Die Summe der Punkte ergibt das erreichte Zertifizierungsniveau. Die Produkte von Lea Ceramiche erhöhen die LEED-Punkte in verschiedenen Kategorien.

ESP

LEED: una calificación para el ambiente.

Lea Ceramiche, a través de la Holding Panariagroup Industrie Ceramiche S.p.A., es miembro del U.S. Green Building Council, organización de Estados Unidos que promueve la realización de edificios y obras respetando el medioambiente, de la salud y del bienestar de las personas que viven y trabajan. Estados Unidos ha elaborado un estándar llamado LEED (Leadership in Energy and Environmental Design): es un sistema de parámetros para la construcción sostenible, que indica la eficiencia ambiental y energética de un edificio.

Se trata de un sistema de "clasificación" para el desarrollo de edificios verdes. LEED atribuye créditos para cada uno de los requisitos de sostenibilidad.

De la suma de los créditos deriva el nivel de certificación obtenido para el edificio. Los productos Lea Ceramiche contribuyen a aumentar la puntuación LEED en diversas categorías.

Certificazioni di prodotto

product certification

certifications de produit

bescheinigung des produkts

certificaciones de producto



DOP001LEA DOP002LEA DOP003LEA DOP004LEA DOP005LEA

05

lea ceramiche

via cameazzo n° 21 - 41042 fiorano modenese (mo) - italy

panariagroup industrie ceramiche spa

EN 14411:2012

Lea Ceramiche Porcelain Tiles: Dry-pressed ceramic tiles with low water absorption $E_b \leq 0,5\%$ for flooring and wall finishes, internal and external applications (DOP001LEA).

Lea Ceramiche Wall Tiles: Dry-pressed ceramic tiles with water absorption level $E_b > 10\%$ for internal wall applications (DOP002LEA).

Slimtech 3mm: Dry pressed ceramic tiles with low water absorption $E_b \leq 0,5\%$ for internal and external wall applications (DOP003LEA).

Slimtech 3Plus: Dry pressed ceramic tiles with low water absorption $E_b \leq 0,5\%$ for internal flooring and internal and external wall applications (DOP004LEA).

Slimtech 5Plus: Dry pressed ceramic tiles with low water absorption $E_b \leq 0,5\%$ for internal flooring and internal and external wall applications (DOP005LEA).

ITA

La marcatura CE è la certificazione di sicurezza del prodotto richiesta dall'Unione Europea, ed ha lo scopo di salvaguardare la salute delle persone e i beni nelle opere di costruzione.

Il nuovo Regolamento UE N. 305/2011 entra in vigore il 1 luglio 2013. La novità più rilevante è l'introduzione della Dichiarazione di Prestazione (DOP, Declaration Of Performance) con la quale il fabbricante comunica i requisiti di sicurezza dei propri materiali.

Le DOP di Lea Ceramiche sono disponibili sul sito internet www.ceramichelea.com.

ENG

The CE mark is the safety product certification required by EU and it is finalized to preserve the people's health and the goods in buildings .

The new Regulation UE N. 305/2011 is valid from the first of July 2013. The most important news is the introduction of the Declaration Of Performance (DOP) with which the supplier communicates the safety requirements concerning own materials.

Lea Ceramiche DOP are available on the website www.ceramichelea.com.

FRA

La marque CE est la certification de sécurité des produits demandé par l'Union Européenne ayant comme objectif la protection et la santé des personnes et des biens dans les ouvrages du bâtiments.

Le nouveau Règlement UE Nr. 305/2011 entre en vigueur le 1er Juillet 2013. La nouveauté la plus importante est l'introduction de la Déclaration de Prestation (DOP, Declaration Of Performance) par la quelle le fabricant communique les caractéristiques de sécurité de ses produits.

Les DOP de Lea Ceramiche sont disponibles sur le site internet www.ceramichelea.com.

DEU

Das CE- Kennzeichnung ist die von EU angefragte Zertifizierung für die Produkt- Sicherheit, und hat das Zweck die Gesundheit der Menschen zu schützen und die Güter in der Bauphase zu bewahren.

Die neue Regelung UE N. 305/2011 tritt am 1.07.2013 in Kraft. Die wichtigste Neuheit ist die Einfügung der Leistungserklärung (DOP, Declaration Of Performance), mit der der Hersteller die Sicherheitsanforderungen eigenen Materialien mitteilt.

Die DOP Lea Ceramiche sind auf Internet Site www.ceramichelea.com verfügbar.

ESP

La marca CE es una certificación de seguridad del producto requerido por la Unión Europea, y su objetivo es salvaguardar la salud de las personas y bienes en las obras de construcción.

El nuevo Reglamento de la UE N ° 305/2011 entró en vigor el 1 de julio de 2013. La novedad más importante es la introducción de la Declaración de rendimiento (DOP, declaración de rendimiento) por el cual el fabricante deberá comunicar los requerimientos de todos sus materiales.

El DOP de Lea Ceramiche están disponibles en el sitio web www.ceramichelea.com.

Certificazioni di prodotto

product certification

certifications de produit

bescheinigung des produkts

certificaciones de producto



Concessione P0061.

Gruppo di prodotto BIa UGL.

Concessione PT0240.

Gruppo di prodotto BIa GL.

marchio certiquality-uni / key mark: garanzia di qualità per il consumatore.

certiquality uni-mark / key mark: a guarantee of quality for the consumer.

le label certiquality-uni / key mark: garantie de qualité pour le consommateur.

certiquality uni-zertifizierung / key mark: qualitätsgarantie für den verbrucher.

certificación certiquality-uni / key mark: garantía de calidad para el consumidor.

Dal 1998 Lea Ceramiche ha richiesto ed ottenuto la certificazione UNI, marchio rilasciato dall'Ente Nazionale di Certificazione (membro CEN Comitato Europeo di Normazione). Dal 2006 Lea Ceramiche ha anche richiesto ed ottenuto il Marchio di Qualità Europeo di prodotto KEY -MARK rilasciato dal CEN. Il marchio KEY-MARK ed il marchio Certiquality-UNI attestano che i prodotti certificati sono conformi alle normative europee per le piastrelle ceramiche.

Lea Ceramiche applied for and obtained UNI approval, a stamp issued by the National Standards Body (member of CEN, European Committee for Standardization) since 1998. Lea Ceramiche applied for and obtained also KEY -MARK, Mark of Quality European of product approval of CEN since 2006. The KEY-MARK and the Certiquality-UNI mark verifies that the approved products conform with European regulations for ceramic tiles.

A partir de 1998, l'entreprise Lea Ceramiche a demandé et obtenu la certification UNI, label délivré par l'Autorité Nationale de Certification (membre CEN Comité Européen de Normalisation). A partir de 2006, l'entreprise Lea Ceramiche a demandé et obtenu aussi la certification le KEY-MARK, Label de Qualité Européenne de produit délivré par le CEN. Le Label KEY-MARK et le Label Certiquality-UNI attestent que les produits certifiés sont conformes aux normes européennes pour les carreaux céramiques.

Seit 1998 besitzt das Unternehmen Lea Ceramiche die UNI-Zertifizierung, die vom italienischen Institut für Normung, Ente Nazionale Italiano di Certificazione, (Mitglied des Europäischen Komitees für Normung CEN) ausgestellt wird. Seit 2006 besitzt das Unternehmen Lea Ceramiche die KEY-MARK-Zertifizierung, Europäischen Qualitätsmark den Produkte. Die Kennzeichnung KEY-MARK und die Kennzeichnung Certiquality-UNI bescheinigt, dass die zertifizierten Produkte den Europäischen Richtlinien für Keramikfliesen entsprechen.

Desde 1998, Lea Ceramiche ha solicitado y obtenido la certificación UNI, concedida por el Ente Nacional de Acreditación (miembro CEN Comité Europeo de Normalización). Desde 2006, Lea Ceramiche también ha solicitado y obtenido la Certificación de Calidad Europea de producto KEYMARK, concedida por el CEN. La certificación KEYMARK es la certificación Certiquality-UNI que da fe de que los productos certificados cumplen con la normativa europea para las baldosas de cerámica.

classement nf-upec



E' una certificazione di prodotto, rilasciata dall'istituto francese CSTB, che verifica l'idoneità tecnica dei prodotti di prima scelta in relazione al tipo di destinazione d'uso.

This is a product approval certificate, issued by the French institute CSTB, who verifies the technical suitability of top quality products in relation to the type of use intended.

Il s'agit d'une certification de produit, délivrée par l'Établissement français CSTB, qui vérifie la conformité technique des produits de premier choix par rapport à la destination d'usage.

Es handelt sich um eine Produktzertifizierung, die vom französischen Institut CSTB ausgestellt wird. Die Behörde prüft die technische Eignung von Erzeugnissen erster Wahl im Verhältnis zu ihrem Verwendungszweck.

Es una certificación de producto, expedida por el instituto francés CSTB, que comprueba la idoneidad técnica de los productos de primera elección en relación con el tipo de uso al que están destinados.

Prodotti certificati

certified products

produits certifiés

zertifizierte erzeugnisse

productos certificados













serie series series series serie	spessore thickness starke epaisseur espesor	colori colors couleurs farben colores	formato sizes formate formats formato	classement upec 	marchiocertiquality-uni key mark n°concessione 		
ancient jerusalem	10 mm	cedron gold - ghion beige - hebron white	48,5x48,5		PT0038		
basaltina stone project	11 mm 12 mm (formato 60x120)	naturale - stuccata - sabbiata - scalpellata texture	30x60	U4P3E3C2	PT0061 (60x60)		
		naturale - stuccata - sabbiata scalpellata - texture	60x60 - 60x120 60x60	U4P3E3C2			
		lappata levigata	30x60 - 60x60 - 60x120 30x60 - 60x60	U3P3E3C2			
		stonehenge	11 mm	savanna - grafite - cardoso antracite		30x60 - 60x60 30x60 - 60x60	U3P3E3C2 U4P3E3C2
		storm	9 mm	icestorm - tropicalstorm - darkstorm		30x30	U4P4E3C2
icestorm - tropicalstorm - darkstorm	45x45			U4P3E3C2			
11 mm	icestorm - tropicalstorm - darkstorm		30x30 - 30x60	U4P3E3C2			
	icestorm - tropicalstorm - darkstorm		60x60	U4P3E3C2			
tecnoquartz	12 mm	doral - silver - gneiss	20x30 - 30x30 - 30x60	U4P4+E3C2	PT0061 (60x60)		
		doral - silver - gneiss	20x60 - 40x60 - 60x60 - 60x120	U4P3E3C2			
		hard black - hot sand	20x30 - 30x30 - 30x60 - 20x60 40x60 - 60x60 - 60x120	U3P3E3C2			
metropolis	10 mm	tokyo white - paris amande - milano ecru rio coffee - london gray - shanghai iron - new york coal - berlin night	30x60	U4P3E3C2			
	10 mm	tokyo white - paris amande - milano ecru rio coffee - london gray - shanghai iron - new york coal - berlin night	60x60	U4P4+E3C2			
	11 mm	tokyo white - paris amande - milano ecru rio coffee - london gray - shanghai iron - new york coal - berlin night	75x75 - 90x90	U4P3E3C2			
arenaria	10 mm	avorio - sabbia - caramel - brown	60,4x60,4		PT0061		
dreaming	10 mm	crystal white - romance safari - passion pulpis	60x60		PT0038		
progetto L14	9 mm	gesso - vaniglia - nocciola - xwhite - xblack	20x40		PT0091		
outdoor	9 mm	dorado - grigio - bruno	20x40,4 - 20x30,2	U4P4E3C2			
	9 mm	dorado - grigio - bruno	20x20	U4P4+E3C2			

Caratteristiche tecniche gres porcellanato

technical characteristics porcelain tiles / caractéristiques techniques du grés cérame

technische eigenschaften des gres feinsteinzeugs / características técnicas gres porcelánico











CONFORME - ACCORDING TO - CONFORME - GEMÄß - IGUAL: iso 13006 G - en 14411 G

	CARATTERISTICHE TECNICHE TECHNICAL CHARACTERISTICS CARACTÉRISTIQUES TECHNIQUES TECHNISCHE EIGENSCHAFTEN CARACTERÍSTICAS TÉCNICAS	metodo di prova iso test method iso méthode d'essai iso prüfmethode iso método de prueba iso	requisiti prescritti required values / valuer require vorgeschriebener wert requisitos prescritos iso 13006 - G / en 14411 - G gruppo / group B1a
	assorbimento d'acqua (E) water absorption (E) absorption d'eau (E) wasserabsorption (E) absorción de agua (E)	iso 10545-3	E ≤ 0,5%
	resistenza alla flessione bending strength résistance à la flexion beigefestigkeit resistencia a la flexión	iso 10545-4	≥ 35 N/mm ² ≥ 355 kg/cm ²
	sfuerzo di rottura (S) breaking strength (S) chargement de rupture (S) bruchlast (S) esfuerzo de rotura (S)	iso 10545-4	spess / thickness ≥ 7,5 mm: ≥ 1300 N spess / thickness < 7,5 mm: ≥ 700 N
	resistenza all'abrasione profonda resistance to deep abrasion résistance à l'abrasion profonde widerstand gegen tiefenabrieb resistencia a la abrasión profunda	iso 10545-6	≤ 175 mm ³
	dilatazione termica lineare linear thermal expansion dilatation thermique linéaire thermische dilatation dilatación térmica linear	iso 10545-8	requisito non previsto iso makes no provision for this test
	resistenza agli sbalzi termici thermal shock resistance résistance aux chocs thermiques temperaturwechselbeständigkeit resistencia a los cambios térmico	iso 10545-9	requisito non previsto iso makes no provision for this test
	resistenza al cavillo crazing resistance résistance au tressillage haarißbeständigkeit resistencia al cuarteado	iso 10545-11	nessuna alterazione no alterations
	resistenza al gelo frost resistance résistance au gel frostbeständigkeit resistencia al hielo	iso 10545-12	nessuna alterazione no alterations
	resistenza attacco chimico chemical resistance résistance chimique chemischee beständigkeit resistencia unión química	iso 10545-13	come indicato dal produttore as indicated by manufacturer
	resistenza chimica a prodotti di uso domestico house hold chemicals resistance résistance aux agents chimique des produits pour emploi domestique chemische beständigkeit gegen haushalt putzmittel resistencia química a productos de uso doméstico	iso 10545-13	ub / gb min.
	resistenza alle macchie stain resistance résistance aux taches fleckenbeständigkeit resistencia a las manchas	iso 10545-14	classe 3 min.
	caratteristiche dimensionali dimensions características dimensionnelles scitenmasse características dimensionales	lunghezza e larghezza length and width longueur et largeur länge und breite longitud y ancho	iso 10545-2 ± 0,6% (15x15 battiscopa) ± 0,75%
		rettezza spigoli straightness of sides rectitude des arêtes kantengeradheit rectilíneidad ángulos	iso 10545-2 ± 0,5%
		ortogonalità rectangularity orthogonalité rechtwinkligkeit ortogonalidad	iso 10545-2 ± 0,6%
		planarità warpage planéité ebenflächigkeit planicidad	iso 10545-2 ± 0,5%
		spessore thickness épaisseur stärke espesor	iso 10545-2 ± 5%

valori values / valeur / wert / valores LEA non smaltato unglazed ugl	valori values / valeur / wert / valores LEA smaltato glazed gl	valori values / valeur / wert / valores LEA levigato - lappato polished - lappato ugl
E ≤ 0,04%	conforme compliant conforme gemäß igual	E ≤ 0,04%
≥ 50 N/mm ² ≥ 510 kg/cm ²	≥ 45 N/mm ² ≥ 460 kg/cm ²	≥ 50 N/mm ² ≥ 510 kg/cm ²
conforme compliant conforme gemäß igual	conforme compliant conforme gemäß igual	conforme compliant conforme gemäß igual
≤ 145 mm ³	non applicabile not applicable no aplicable nicht anwendbar no aplicable	≤ 145 mm ³
α ≤ 7x10 ⁻⁶ °C ⁻¹	α ≤ 7x10 ⁻⁶ °C ⁻¹	α ≤ 7x10 ⁻⁶ °C ⁻¹
resistente resistant résistant beständig resistente	resistente resistant résistant beständig resistente	resistente resistant résistant beständig resistente
non applicabile not applicable no aplicable nicht anwendbar no aplicable	resistente resistant résistant beständig resistente	non applicabile not applicable no aplicable nicht anwendbar no aplicable
resistente resistant résistant beständig resistente	resistente resistant résistant beständig resistente	resistente resistant résistant beständig resistente
ula - uha (resistente) (resistant) (résistant) (beständig) (resistente)	gla - gha (resistente) (resistant) (résistant) (beständig) (resistente)	ula - uha (resistente) (resistant) (résistant) (beständig) (resistente)
ua (resistente) (resistant) (résistant) (beständig) (resistente)	ga (resistente) (resistant) (résistant) (beständig) (resistente)	conforme compliant conforme gemäß igual
classe 5 (resistente) (resistant) (résistant) (beständig) (resistente)	classe 5 (resistente) (resistant) (résistant) (beständig) (resistente)	conforme compliant conforme gemäß igual
± 0,6% (15x15 battiscopa) ± 0,5%	± 0,6% (15x15 battiscopa) ± 0,5%	± 0,6% (15x15 battiscopa) ± 0,5%
± 0,3% rettificato / rectified ± 0,2%	± 0,3% rettificato / rectified ± 0,2%	± 0,3% rettificato / rectified ± 0,2%
± 0,3% rettificato / rectified ± 0,2%	± 0,3% rettificato / rectified ± 0,2%	± 0,3% rettificato / rectified ± 0,2%
± 0,5%	± 0,5%	± 0,5%
± 5%	± 5%	± 5%

Technical characteristics porcelain tiles

ACCORDING TO ANSI 137.1 GLAZED AND UNGLAZED PORCELAIN TILES (CLASS P1)

	TECHNICAL CHARACTERISTICS	test method astm	required values ansi 137.1		
	water absorption	astm c373	≤ 0.5%		
	breaking strength	astm c648	≥ 250 pounds		
	resistance to abrasion wear	astm c501	lw ≥ 100		
	deep abrasion resistance	astm c1243	≤ 175 mm ³		
	linear thermal expansion	astm c372	not required		
	thermal shock resistance	astm c484	no alterations		
	chemical resistance	astm c650	not required		
	frost resistance	astm c1026	not required		
	bond resistance	astm c482	≥ 50 PSI		
	stain resistance	CTI 81-7 Ann. D	not required		
	dimensions	edge warpage	astm c485	rectified ± 0.40% or max ± 0.05 inch for tiles up to 24"x24" or max ± 0.07 inch for tiles larger than 24"x24"	calibrated ± 0.75% or max ± 0.09 inch
		diagonal warpage	astm c485	rectified ± 0.40% or max ± 0.07 inch	calibrated ± 0.50% or max ± 0.08 inch
		nominal dimensions	astm c499	rectified - 3.0% / + 2.0% of normal dimensions	calibrated ± 3.0% or max ± 0.08 inch
		caliber range	astm c499	rectified ± 0.25% or max ± 0.03 inch	calibrated ± 0.50% or max ± 0.08 inch
		tickness	astm c499	≤ 0.040 inch	
		wedging	astm c502	rectified ± 0.25% or max ± 0.03 inch	calibrated ± 0.50% or max ± 0.08 inch

values LEA unglazed ugl	values LEA glazed gl	values LEA polished - lappato ugl
compliant	compliant	compliant
compliant	compliant	compliant
lw ≥ 200	not applicable	lw ≥ 200
≤ 145 mm ³	not applicable	≤ 145 mm ³
$\alpha \leq 8 \times 10^{-6} \text{ } ^\circ\text{C}^{-1}$ $\alpha \leq 4.4 \times 10^{-6} \text{ } ^\circ\text{F}^{-1}$	$\alpha \leq 8 \times 10^{-6} \text{ } ^\circ\text{C}^{-1}$ $\alpha \leq 4.4 \times 10^{-6} \text{ } ^\circ\text{F}^{-1}$	$\alpha \leq 8 \times 10^{-6} \text{ } ^\circ\text{C}^{-1}$ $\alpha \leq 4.4 \times 10^{-6} \text{ } ^\circ\text{F}^{-1}$
not applicable	resistant	not applicable
resistant	resistant	resistant
resistant	resistant	resistant
compliant	compliant	compliant
resistant	resistant	resistant
compliant	compliant	compliant
compliant	compliant	compliant
± 1.5%	± 1.5%	± 1.5%
compliant	compliant	compliant
≤ 0.030 inch	≤ 0.030 inch	≤ 0.030 inch
compliant	compliant	compliant

Caratteristiche tecniche rivestimenti in monoporosa in pasta bianca smaltata











technical characteristics of glazed white body porous single-fired tiles

caractéristiques techniques revêtement monocuissons en pâte blanche émaillé

technische eigenschaften wandfliesen aus weissscherbigen glasierten monoporosa











características técnicas revestimientos en monoporosa de pasta blanca esmaltada

CONFORME - ACCORDING TO - CONFORME - GEMÄß - IGUAL: iso 13006 L - en 14411 L

	CARATTERISTICHE TECNICHE TECHNICAL CHARACTERISTICS CARACTÉRISTIQUES TECHNIQUES TECHNISCHE EIGENSCHAFTEN CARACTERÍSTICAS TÉCNICAS	metodo di prova iso test method iso méthode d'essai iso prüfmethode iso método de prueba iso	requisiti prescritti required values / valeur requise vorgeschriebener wert requisitos prescritos iso 13006 - L / en 14411 - L gruppo / group BIII gl	valori values / valeur / wert / valores LEA smaltato glazed gl
	assorbimento d'acqua (e) water absorption (e) absorption d'eau (e) wasserabsorption (e) absorción de agua (e)	iso 10545-3	E> 10%	E> 10%
	resistenza alla flessione bending strength résistance à la flexion beigefestigkeit resistencia a la flexión	iso 10545-4	spess / thickness > 7,5 mm ≥ 12 N/mm ² ≥ 122 kg/cm ²	≥ 18 N/mm ² ≥ 185 kg/cm ²
	sforzo di rottura (s) breaking strength (s) changement de rupture (s) bruchlast (s) esfuerzo de rotura (s)	iso 10545-4	spess / thickness ≥ 7,5 mm ≥ 600 N	conforme compliant conforme gemäß igual
	dilatazione termica lineare linear thermal expansion dilatation thermique linéaire thermische dilatation dilatación térmica lineare	iso 10545-8	requisito non previsto iso makes no provision for this test	α≤7x10 ⁻⁶ °C ⁻¹
	resistenza agli sbalzi termici thermal shock resistance résistance aux chocs thermiques temperaturwechselbeständigkeit resistencia a los cambios térmico	iso 10545-9	requisito non previsto iso makes no provision for this test	resistente resistant résistant beständig resistente
	resistenza al cavillo crazing resistance résistance au tressilage haarißbeständigkeit resistencia al cuarteado	iso 10545-11	nessuna alterazione no alterations	resistente resistant résistant beständig resistente
	resistenza al gelo frost resistance résistance au gel frostbeständigkeit resistencia al hielo	iso 10545-12	requisito non previsto iso makes no provision for this test	non resistente not resistant ne résiste pas nicht beständig no resistente
	resistenza attacco chimico chemical resistance résistance chimique chemische beständigkeit resistencia unión química	iso 10545-13	come indicato dal produttore as indicated by manufacturer	gla - gha (resistente) (résistant) (beständig) (resistente)
	resistenza chimica a prodotti di uso domestico house hold chemicals resistance résistance aux agents chimique des produits pour emploi domestique chemische beständigkeit gegen haushalt putzmittel resistencia química a productos de uso doméstico	iso 10545-13	gb min.	ga (resistente) (résistant) (beständig) (resistente)
	resistenza alle macchie stain resistance résistance aux taches fleckenbeständigkeit resistencia a las manchas	iso 10545-14	classe 3 min.	classe 5 (resistente) (résistant) (beständig) (resistente)
	caratteristiche dimensionali dimensions caractéristiques dimensionnelles scitenmasse características dimensionales	lunghezza e larghezza length and width longueur et largeur länge und breite longitud y ancho	iso 10545-2	lato > 12 cm ± 0,5%
	rettezza spigoli straightness of sides rectitude des arêtes kantengeradheit rectilíneidad ángulos	iso 10545-2	± 0,3%	± 0,2%
	ortogonalità rectangularity orthogonalité rechtwinkigkeit ortogonalidad	iso 10545-2	± 0,5%	± 0,3%
	planarità warpage planéité ebenflächigkeit planicidad	iso 10545-2	curvatura del centro + 0,5% / - 0,3% curvatura del lato + 0,5% / - 0,3% svergolamento ± 0,5%	± 0,3%
	spessore thickness épaisseur stärke espesor	iso 10545-2	± 10%	± 10%

Technical characteristics of glazed white body porous single-fired tiles

ACCORDING TO ANSI 137.1 GLAZED NON VITREOUS WALL TILES (CLASS P4)











TECHNICAL CHARACTERISTICS	test method astm	required values ansi 137.1	values LEA glazed gl		
 water absorption	astm c373	7% < E ≤ 20%	7% < E ≤ 20%		
 breaking strength	astm c648	≥ 125 pounds	compliant		
 linear thermal expansion	astm c372	not required	$\alpha \leq 8 \times 10^{-6} \text{ } ^\circ\text{C}^{-1}$ $\alpha \leq 4.4 \times 10^{-6} \text{ } ^\circ\text{F}^{-1}$		
 thermal shock resistance	astm c484	no alterations	resistant		
 crazing resistance	astm c424	no alterations	resistant		
 chemical resistance	astm c650	not required	resistant		
 frost resistance	astm c1026	not required	not resistant		
 bond resistance	astm c482	≥ 50 PSI	compliant		
 stain resistance	CTI 81-7 Ann. D	not required	resistant		
 dimensions	edge warpage	astm c485	rectified - 0.30% / + 0.40% or max - 0.04 inch / + 0.05 inch	calibrated - 0.30% / + 0.40% or max - 0.04 inch / + 0.05 inch	compliant
	diagonal warpage	astm c485	rectified - 0.30% / + 0.40% or max - 0.04 inch / + 0.05 inch	calibrated - 0.30% / + 0.40% or max - 0.04 inch / + 0.05 inch	compliant
	nominal dimensions	astm c499	rectified ± 2.0% of nominal dimensions	calibrated ± 2.0% of nominal dimensions	± 1.0%
	caliber range	astm c499	rectified ± 0.25% or max ± 0.03 inch	calibrated ± 0.30% or max ± 0.04 inch	compliant
	tickness	astm c499	≤ 0.031 inch		compliant
	wedging	astm c502	rectified ± 0.25% or max ± 0.03 inch	calibrated ± 0.40% or max ± 0.05 inch	compliant

Caratteristiche tecniche

technical characteristics / caractéristiques techniques

technische eigenschaften / características técnicas



	CARATTERISTICHE TECNICHE TECHNICAL CHARACTERISTICS CARACTÉRISTIQUES TECHNIQUES TECHNISCHE EIGENSCHAFTEN CARACTERÍSTICAS TÉCNICAS	metodo di prova iso test method iso méthode d'essai iso prüfmethode iso método de prueba iso	requisiti prescritti required values / valeurs requises vorgeschriebener wert requisitos prescritos iso 13006 - G / en 14411 - G Bla ugl
	assorbimento d'acqua (e) water absorption (e) absorption d'eau (e) wasserabsorption (e) absorción de agua (e)	iso 10545-3	≤ 0,5%
	resistenza alla flessione bending strength résistance à la flexion beigefestigkeit resistencis a la flexión	iso 10545-4	≥ 35 N/mm ²
	sforzo di rottura (s) breaking strength (s) chargement de rupture (s) bruchlast (s) esfuerzo de rotura (s)	iso 10545-4	≥ 700 N
	resistenza all'abrasione profonda résistance to deep abrasion résistance à l'abrasion profonde widerstand gegen tiefenabrier resistencia a la abrasión profunda	iso 10545-6	≤ 175 mm ³
	resistenza a compressione resistance to compression résistance à la compression druckfestigkeit resistencia a compresión	-	-
	resistenza agli sbalzi termici thermal shock resistance résistance aux chocs thermiques temperaturwechselbeständigkeit resistencia a los cambios térmico	iso 10545-9	requisito non previsto iso makes no provision for this test
	resistenza al gelo frost resistance résistance au gel frostbeständigkeit resistencia al hielo	iso 10545-12	nessuna alterazione no alterations
	resistenza attacco chimico chemical resistance résistance chimique chemischee beständigkeit resistencia unión química	iso 10545-13	come indicato dal produttore as indicated by manufacturer
	resistenza alle macchie stain resistance résistance aux taches fleckenbeständigkeit resistencia a las manchas	iso 10545-14	≥ classe 3
	caratteristiche dimensionali dimensions caractéristiques dimensionnelles scitenmasse características dimensionales	lunghezza e larghezza length and width longueur et largeur länge und breite longitud y ancho	iso 10545-2 ± 0,6%
		rettezza spigoli straightness of sides rectitude des arêtes kantengeradheit rectitudinalidad ángulos	iso 10545-2 ± 0,5%
		ortogonalità rectangularity orthogonalité rechtwinkligkeit ortogonalidad	iso 10545-2 ± 0,6%
		planarità warpage planéité ebenflächigkeit planicidad	iso 10545-2 ± 0,5%
		spessore thickness épaisseur stärke espesor	iso 10545-2 ± 5%

valori values / valeur / wert / valores LEA slimtech 3mm	valori values / valeur / wert / valores LEA slimtech 3plus	valori values / valeur / wert / valores LEA slimtech 5plus
≤0,1%	≤0,1%*	≤0,1%*
≥ 35 N/mm ²	≥ 120 N/mm ^{2**}	≥ 55 N/mm ^{2**}
non richiesto materiale da rivestimento not required for wall tiles	≥ 1000 N**	≥ 1200 N**
conforme compliant conforme gemäß igual	conforme compliant conforme gemäß igual	conforme compliant conforme gemäß igual
non richiesto materiale da rivestimento not required for wall tiles	≥ 400 N/mm ²	≥ 400 N/mm ²
resistente resistant résistant beständig resistente	resistente resistant résistant beständig resistente	resistente resistant résistant beständig resistente
resistente resistant résistant beständig resistente	resistente resistant résistant beständig resistente	resistente resistant résistant beständig resistente
ula - uha (resistente) (resistant) (résistant) (beständig) (resistente)	ula - uha (resistente) (resistant) (résistant) (beständig) (resistente)	ula - uha (resistente) (resistant) (résistant) (beständig) (resistente)
classe 5 (resistente) (resistant) (résistant) (beständig) (resistente)	classe 5 (resistente) (resistant) (résistant) (beständig) (resistente)	classe 5 (resistente) (resistant) (résistant) (beständig) (resistente)
± 0,6%	± 0,6%	+ 0,6%
± 0,2%	± 0,2%	+ 0,2%
± 0,2%	± 0,2%	+ 0,2%
± 0,5%	± 0,5%	+ 0,5%
± 5%	± 5%	+ 5%

*valore medio riferito al materiale ceramico - average value referred to ceramic material only

**valore medio riferito al pezzo completo (lastra e rinforzo) - average value referred to the all-in-one piece (slab and fiberglass)

Caratteristiche tecniche

technical characteristics / caractéristiques techniques

technische eigenschaften / características técnicas



	CARATTERISTICHE TECNICHE TECHNICAL CHARACTERISTICS CARACTÉRISTIQUES TECHNIQUES TECHNISCHE EIGENSCHAFTEN CARACTERÍSTICAS TÉCNICAS	metodo di prova test method méthode d'essai prüfmethode método de prueba	riferimenti per la classificazione references for the classification références pour la classification hinweise für die einstuflung referencias para la clasificación
	caratteristiche di resistenza allo scivolamento slip resistance features / caractéristiques de résistance au glissement / eigenschaften rutschfestigkeit /		
	coefficiente di attrito dinamico	B.C.R. tortus	>0,40 L. 13/89 - DM. 236/89 D. Lgs. 503/96
	resistenza allo scivolamento slip resistance résistance au glissement rutschfestigkeit resistencia al deslizamiento	din 51130	r9 6° ≤ α ≤ 10° r10 10° < α ≤ 19°
	caratteristiche termiche thermal features / caractéristiques thermiques / wärmeeigenschaften / características termales		
	conducibilità termica heat conducting ability conductibilité thermique wärmeleitfähigkeit conductividad térmica	uni en 12524:2001	-
	caratteristiche di reazione al fuoco - posa a rivestimento fire reaction features - place on coating / caractéristiques de réaction au feu - pose en revêtement /		
	reazione al fuoco fire resistance caractéristique de résistance au feu eigenschaften der feuerbeständigkeit características de resistencia al fuego	iso / dis 1182.2	Normativa Italiana D.M. 14/01/85 D.M. 15/03/05
	reazione al fuoco fire resistance caractéristique de résistance au feu eigenschaften der feuerbeständigkeit características de resistencia al fuego	uni en iso 13823:2005	Normativa Europea direttiva 89/106/CE - decisione 2000/147/CE UNI EN 13501-1:2005 European Regulations Normes Européennes Europäische Bestimmungen Normativa Europea
	caratteristiche di reazione al fuoco - posa a pavimento fire reaction features - place on floor / caractéristiques de réaction au feu - pose au sol /		
	reazione al fuoco fire resistance caractéristique de résistance au feu eigenschaften der feuerbeständigkeit características de resistencia al fuego	iso / dis 1182.2	Normativa Italiana D.M. 14/01/85 D.M. 15/03/05
	reazione al fuoco fire resistance caractéristique de résistance au feu eigenschaften der feuerbeständigkeit características de resistencia al fuego	uni en iso 9239:2006	Normativa Europea direttiva 89/106/CE - decisione 2000/147/CE UNI EN 13501-1:2005 European Regulations Normes Européennes Europäische Bestimmungen Normativa Europea

slimtech 3mm	slimtech 3plus	slimtech 5plus
--------------	----------------	----------------

características de resistencia al deslizamiento

non richiesto materiale da rivestimento	>0,40 (escluso RE-evolution) cuoio - asciutto / gomma - bagnato	>0,40 cuoio - asciutto / gomma - bagnato
non richiesto materiale da rivestimento not required for wall tiles	r9 (escluso RE-evolution - except RE-evolution)	r10 (wood-stock)

$\lambda = 1,3 \text{ W/m}^\circ\text{K}$
 $\lambda = 1,1 \text{ kcal/mh}^\circ\text{C}$
 $\lambda = 0.7 \text{ Btu/fth}^\circ\text{F}$

$\lambda = 1,3 \text{ W/m}^\circ\text{K}$
 $\lambda = 1,1 \text{ kcal/mh}^\circ\text{C}$
 $\lambda = 0.7 \text{ Btu/fth}^\circ\text{F}$

$\lambda = 1,3 \text{ W/m}^\circ\text{K}$
 $\lambda = 1,1 \text{ kcal/mh}^\circ\text{C}$
 $\lambda = 0.7 \text{ Btu/fth}^\circ\text{F}$

eigenschaften der reaktion auf feuerbeständigkeit - verlegung der verkleidung / características de reacción al fuego - pose de revestimiento











classe 0	classe 1	classe 1
classe A1 class classe klasse clase	classe A2 - s1,d0 class classe klasse clase	classe A2 - s1,d0 class classe klasse clase

eigenschaften der reaktion auf feuerbeständigkeit - bodenverlegung / características de reacción al fuego - pose de piso



classe 0	classe 1	classe 1
classe A1 _n class classe klasse clase	classe A2 _n - s1 class classe klasse clase	classe A2 _n - s1 class classe klasse clase

Technical characteristics



	TECHNICAL SPECIFICATIONS	test method	requirements ansi 137.1 porcelain tile - P1 class	
	water absorption (E)	astm c373	≤ 0.5%	
	breaking strength	astm c648	≥ 250 pounds	
	resistance to abrasion wear	astm c501	lw ≥ 100	
	deep abrasion resistance	astm c1243	≤ 175 mm ³	
	linear thermal expansion	astm c372	not required	
	thermal shock	astm c484	no alterations	
	chemical resistance	astm c650	not required	
	frost resistance	astm c1026	not required	
	bond resistance	astm c482	≥ 50 PSI	
	stains resistance	CTI 81-7 Ann. D	not required	
	dimensions	edge warpage	astm c485	± 0.40% or max ± 0.05 inch for tiles up to 24"x24" or max ± 0.07 inch for tiles larger than 24"x24"
		diagonal warpage	astm c485	± 0.40% or max ± 0.07 inch
		nominal dimensions	astm c499	- 3.0% / + 2.0% of normal dimensions
		caliber range	astm c499	± 0.25% or max ± 0.03 inch
		tickness	astm c499	≤ 0.040 inch
		wedging	astm c502	± 0.25% or max ± 0.03 inch

SLIP RESISTANCE ACCORDING TO CERAMIC TILE INSTITUTE CLASSIFICATION

	TECHNICAL SPECIFICATIONS	test method	requirements
	coefficient of friction	astm c1028	COF < 0.50 questionable 0.50 ≤ COF < 0.50 conditionally slip resistant COF ≥ 0.60 slip resistant
	dynamic coefficient of friction	ansi 137.1: par. 6.2.2.1.10 (BOT 3000)	DCOF ≥ 0.42 (wet internal spaces)

*average value referred to ceramic material
 **average value referred to the all-in-one piece (slab and fiberglass)

slimtech 3mm	slimtech 3plus	slimtech 5plus
compliant	compliant*	compliant*
not required wall tiles	compliant**	compliant**
$lw \geq 200$	$lw \geq 200$	$lw \geq 200$
compliant	compliant	compliant
$\alpha \leq 8 \cdot 10^{-6} \text{ } ^\circ\text{C}^{-1}$ $\alpha \leq 4.4 \cdot 10^{-6} \text{ } ^\circ\text{F}^{-1}$	$\alpha \leq 8 \cdot 10^{-6} \text{ } ^\circ\text{C}^{-1}$ $\alpha \leq 4.4 \cdot 10^{-6} \text{ } ^\circ\text{F}^{-1}$	$\alpha \leq 8 \cdot 10^{-6} \text{ } ^\circ\text{C}^{-1}$ $\alpha \leq 4.4 \cdot 10^{-6} \text{ } ^\circ\text{F}^{-1}$
resistant	resistant	resistant
resistant	resistant	resistant
resistant	resistant	resistant
compliant	compliant	compliant
resistant	resistant	resistant
compliant	compliant	compliant
compliant	compliant	compliant
$\pm 1.5\%$	$\pm 1.5\%$	$\pm 1.5\%$
compliant	compliant	compliant
$\leq 0.030 \text{ inch}$	$\leq 0.030 \text{ inch}$	$\leq 0.030 \text{ inch}$
compliant	compliant	compliant

slimtech 3mm	slimtech 3plus	slimtech 5plus
not required wall tiles	dry - neolite COF ≥ 0.60 wet - neolite COF ≥ 0.60 (except RE-evolution)	dry - neolite ≥ 0.60 wet - neolite ≥ 0.60 (wood-stock)
not required wall tiles	DCOF ≥ 0.42 (except RE-evolution)	DCOF ≥ 0.42 (wood-stock)

Protezione antibatterica Microban

Microban antibacterial protection

Microban protection antibactérienne

Microban antibakteriellen schutz

ITA

Abbiamo scelto Microban® leader mondiale nella tecnologia antibatterica, per rendere ancora più sicure le nostre piastrelle.

La protezione Microban viene integrata direttamente nelle piastrelle, durante il processo produttivo: quando i batteri entrano in contatto con la superficie trattata, la tecnologia Microban agisce bloccandone il metabolismo. In questo modo si interrompe il ciclo vitale dei batteri, che pertanto non sono più in grado di proliferare e sopravvivere.

Grazie alla tecnologia integrata a base di argento, le nostre piastrelle sono protette da un innovativo scudo antibatterico che elimina fino al 99,9% dei batteri dalla superficie e assicura una protezione inalterabile da usura, condizioni climatiche e ripetute pulizie in qualsiasi ambiente di utilizzo. La tecnologia Microban funziona 24 ore su 24 garantendo di fatto una protezione continua giorno e notte, mantenendo le piastrelle più pulite fra una pulizia e l'altra. La tecnologia Microban, con la sua continua azione antibatterica, previene la formazione di bio-films. I bio-films sono colonie di batteri che creano uno strato sulla superficie. Queste colonie possono danneggiare la superficie che abitano (ad esempio piastrelle in ceramica) e una volta che la pellicola ha raggiunto un determinato stadio l'aspetto estetico del prodotto può variare. Considerazioni estetiche a parte, l'accumulo di un bio-film comporta una sfida aggiuntiva per il mantenimento dell'igiene della superficie. A differenza dei disinfettanti che rappresentano una soluzione istantanea, ma di breve durata, Microban® garantisce una protezione durevole, esercitando un'azione continua contro i batteri durante l'intero ciclo di vita del prodotto. La tecnologia Microban è stata sottoposta a prove approfondite eseguite da laboratori indipendenti e gode di una lunga storia che ne garantisce la sicurezza d'uso. È registrata in Europa ai sensi della Direttiva sui prodotti biocidi per tutte le applicazioni in cui è utilizzata. Gli additivi Microban sono incorporati in beni di consumo, manufatti industriali e dispositivi medici prodotti da aziende leader in tutto il mondo ed oggi è a beneficio esclusivo di Lea Ceramiche e Panariagroup, da sempre all'avanguardia!

ENG

We have chosen Microban®, the global leader in antibacterial technology, to make our tiles even safer.

The Microban protection is incorporated into the tiles during the production process; once bacteria come into contact with the Microban surface, the technology works by disrupting its biological functioning, the lifecycle cannot proceed and the bacteria then die. Thanks to built-in technology based on silver, our tiles are protected by an innovative antibacterial shield that eliminates up to 99.9% of bacteria on the surface of the tile and assures long-lasting protection against wear and tear, climatic conditions and repeated cleans in any usage environment. Microban technology is active 24 hours a day, guaranteeing continuous protection day and night, keeping the tiled surface more hygienic between cleanings. The continuous antibacterial action of Microban technology prevents the build-up of biofilms. Biofilms are colonies of bacteria which form a coating upon a surface. These colonies can be damaging to the surface that they inhabit, such as ceramic tiles and once the formation of the biofilm has reached a certain stage can mar the visual appearance of the product. In addition to aesthetic considerations, the build-up of a biofilm creates an additional challenge in maintaining surface hygiene. Disinfectants are an instant but short term solution that provide only a limited residual activity once the treated surface area dries and bacteria can very quickly start to grow and reproduce. As an alternative, Microban® technology guarantees long-lasting protection, continuously working to prevent the growth of bacteria throughout the entire life cycle of the product. Microban technology has undergone rigorous trials conducted by independent laboratories and benefits from a long history that guarantees its safety of use. It is registered in Europe under the Biocidal Products Directive for all applications in which it is used. Microban technology is incorporated into consumer goods, industrial products and medical equipment manufactured by some of the world's leading companies. This technology is available exclusively in Europe to Lea Ceramiche and Panariagroup: always at the cutting edge!

FRA

Nous avons choisi Microban®, le leader mondial en technologie antibactérienne, pour rendre nos carrelages encore plus sûrs.

La protection Microban est incorporée directement dans les carrelages pendant le processus de fabrication: lorsque des bactéries entrent en contact avec la surface traitée, la technologie Microban réagit, bloquant le métabolisme des bactéries. Cela interrompt donc le cycle de vie des bactéries qui ne peuvent plus se proliférer et survivre. Grâce à la technologie incorporée basée sur l'argent, nos carrelages sont protégés par un bouclier antibactérien innovateur qui élimine jusqu'à 99,9% des bactéries sur les surfaces et assure une protection durable contre l'usure, les conditions climatiques et les nettoyages à répétition dans tous les lieux d'utilisation. La technologie Microban reste active 24 heures par jour, ce qui garantit une protection ininterrompue jour et nuit, maintenant les carrelages dans un état plus hygiénique entre les nettoyages. La technologie Microban, avec son action antibactérienne continue, empêche la formation de bio-films. Les Bio-films sont des colonies de bactéries qui créent une couche sur la surface. Ces colonies peuvent endommager la surface (comme par exemple carreaux de céramique) et une fois que ce film a atteint un certain stade l'apparence du produit peuvent changer. Les considérations esthétiques mis à part, l'accumulation du bio-film dans est un défi supplémentaire pour le maintien de l'hygiène des surfaces. Contrairement aux désinfectants qui apportent une solution instantanée, mais non durable, Microban® garantit une solution durable, assurant une action permanente contre les bactéries tout au long du cycle de vie du produit. La technologie Microban a fait l'objet d'essais rigoureux effectués par des laboratoires indépendants, et s'appuie sur une longue histoire qui garantit sa sûreté en cours d'utilisation. Elle est enregistrée en Europe aux termes de la directive sur les produits biocides pour toutes les applications dans lesquelles elle est utilisée. Les adjuvants Microban sont incorporés dans des produits de grande consommation, des produits industriels et des équipements médicaux fabriqués par quelques-unes des plus grandes sociétés au monde. À l'heure actuelle, cette technologie est disponible exclusivement auprès de Lea Ceramiche et du Panariagroup: toujours à la pointe de la technologie.

DEU

Unsere Entscheidung: Microban® – weltweit führend bei antibakteriellen Technologien – damit unsere Keramikfliesen noch sicherer werden.

Der antibakterielle Hygieneschutz von Microban wird während des Herstellungsverfahrens direkt in die Fliesen integriert: Gelangen Bakterien mit der so behandelten Oberfläche in Kontakt, reagiert die Microban Technologie und blockiert die Stoffwechselvorgänge der Erreger. Auf diese Weise kommt es zu einem Eingriff in den Lebenszyklus der Keime, die sich nicht mehr vermehren können und absterben. Dank der auf Silber basierenden und in den Produkten integrierten Technologie sind unsere Fliesen mit einem innovativen antibakteriellen Schuttschild ausgestattet, von dem bis zum 99,9% aller Bakterien auf Oberflächen eliminiert werden, und das in allen Einsatzbereichen vor Abnutzung, bei jeder Wetterlage wie auch vor wiederholtem Reinigen versichert ist. Damit nicht genug: Die Microban Technologie ist rund um die Uhr aktiv, garantiert kontinuierlichen Schutz rund um die Uhr und sorgt für hygienische Oberflächen – auch zwischen den Reinigungsvorgängen. Die Technologie "MICROBAN", mit ihrer dauerhaften antibakteriellen Wirkung, beugt der Bildung von Bio-Films vor. Die Bio-Films bestehen aus Kolonien von Bakterien die eine Schicht auf der Oberfläche bilden. Diese Kolonien können die von ihnen bewohnte Oberfläche (z. B. Keramikfliesen) beschädigen, und wenn diese Schicht eine bestimmte Dichte erreicht hat, kann die ästhetische Beschaffenheit des Produkts ändern. Abgesehen von den ästhetischen Betrachtungen, wird die Ablagerung von Bio-Films ein zusätzliches Hindernis für die Sauberhaltung der Oberfläche verursachen. Desinfektionsmittel sind eine Sofortmaßnahme – sie sind aber keine langfristige Lösung. Im Gegensatz dazu schafft Microban® garantiert langfristige Abhilfe und stellt während der gesamten Nutzungsdauer des Produkts kontinuierliche antibakterielle Wirkung bereit. Von unabhängigen Laboratorien wurde die Microban Technologie rigorosen wissenschaftlichen Prüfungen unterzogen und sie profitiert außerdem von ihrem langjährigen praktischen Einsatz, der ihre Gebrauchssicherheit gewährleistet. Innerhalb von Europa wurde Microban® für alle seine Einsatzbereiche nach der Richtlinie für Biozid-Produkte zugelassen. Der Microban Hygieneschutz wird weltweit von einer Reihe führender Hersteller bereits bei der Herstellung in Gebrauchsgüter, Industrieerzeugnisse und Medizinprodukte integriert. Heute ist diese Technologie exklusiv verfügbar in den Produkten von Lea Ceramiche und der Panariagroup: immer an vorderster Front!

Non trattato

Unprotected / Sans traitement / Nicht ausgestattet

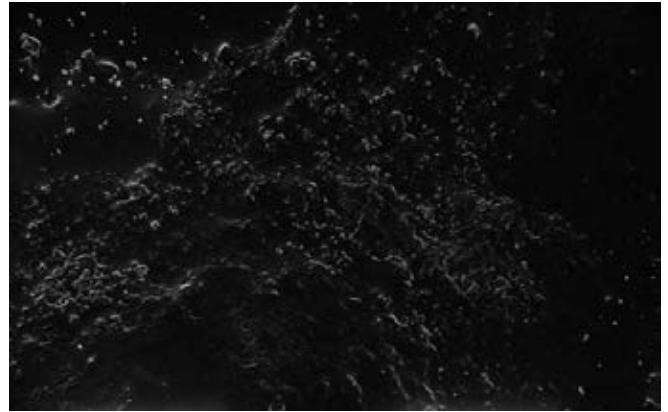
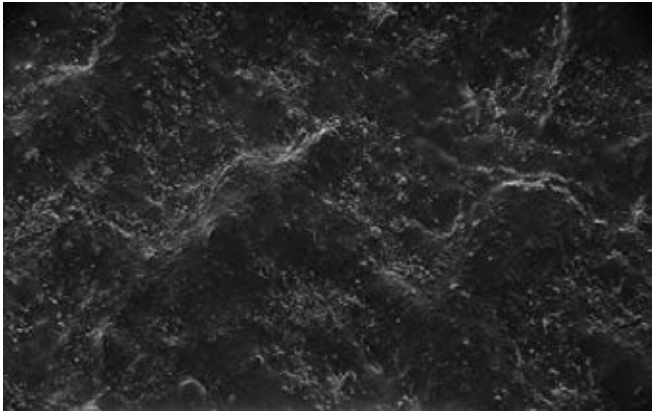

Trattato con Microban[®]

Microban[®] antibacterial protection / Avec traitement Microban[®] / Mit Microban[®] ausgestattet



Grazie alla tecnologia Microban[®], le nostre piastrelle sono protette da un innovativo scudo antibatterico che elimina fino al 99,9% dei batteri dalla superficie 24 su ore 24; garantendo una protezione continua.

Thanks to Microban[®] technology, our tiles are protected by an innovative antibacterial shield that eliminates up to 99,9% of bacteria on the surface of the tile 24/7, guaranteeing continuous protection day and night.

Grâce à la technologie Microban[®], nos carreaux sont protégés par un bouclier antibactérien innovant qui élimine jusqu'à 99,9% des bactéries sur les surfaces en assurant une protection durable, 24 heures par jour.

Dank der Microban[®] Technologie sind unsere Fliesen mit einem innovativen antibakteriellen Schutzschild ausgestattet, von dem bis zum 99,9% aller Bakterien auf Oberflächen eliminiert werden. Die Microban Technologie ist rund um die Uhr aktiv, garantiert kontinuierlichen Schutz rund um die Uhr und sorgt für hygienische Oberflächen.

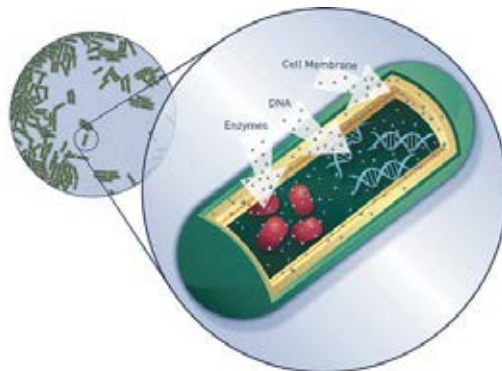

La tecnologia Microban[®] si lega a vari elementi presenti nei batteri, come enzimi, proteine, membrane cellulari e DNA.

Metal ions in the Microban[®] technology bind to various targets in the bacteria, such as enzymes, proteins, cell membranes and DNA.

La technologie MICROBAN se lie avec différents éléments qui se trouvent dans les bactéries: enzymes, protéines, membranes cellulaires et ADN.

Die Microban Technologie verbindet sich mit verschiedenen Elementen wie Enzymen, Proteinen, Zellmembran und DNA der Bakterien, die in den Bakterien selbst sich befinden, um diese zu zerstören.

Posa Elemento ad Elle e Gradino Continuo

Effettuare sempre la posa con adesivo. Tutti i gradini continui sono da posare esclusivamente in interno.

Per la posa su sottofondi cementizi utilizzare adesivi elastici di classe S2 secondo EN 12004. Nel caso di posa su altri supporti (es. legno, truciolare, ...) contattare i fornitori per la scelta dell'adesivo più idoneo.

Verificare che il sottofondo sia stabile, planare e pulito. Gli strati cementizi (massetti, calcestruzzo, strati di livellamento/pendenza, ...) devono essere stagionati, cioè devono aver esaurito i fenomeni di ritiro.

Evitare la presenza di acqua sul sottofondo. Nel caso in cui la pavimentazione in esercizio sarà a contatto con l'acqua (ambienti esterni, centri benessere, docce, spogliatoi, ...) è necessario:

- realizzare sottofondi con pendenza di almeno l'1% (1 cm per ogni metro)
- applicare idonei impermeabilizzanti sulla superficie del sottofondo
- miscelare gli stucchi con idonei lattici che riducano la porosità delle fughe.

NON LASCIARE VUOTI sotto gli Elementi ad Elle e Gradini Continui, posare con "doppia spalmatura" anche nella parte verticale dei pezzi.

Il bordo verticale di Elementi ad Elle e Gradini Continui deve essere distanziato di alcuni mm (almeno 3-4 mm) dal sottofondo e lo spazio vuoto deve essere riempito con collante, v. figure.

Calpestare gli Elementi ad Elle/Gradini Continui e riempire le fughe solo quando l'adesivo ha fatto presa secondo le indicazioni riportate dai fabbricanti.

Posare sempre con la fuga, che dovrà avere idonee dimensioni e comunque calcolata dal progettista.

Prevedere nella pavimentazione i giunti perimetrali a contatto con elementi strutturali verticali (muri, colonne, ...) ed idonei giunti di dilatazione.

Evitare sistemi rigidi:

- volendo rivestire la parte verticale degli scalini ("alzata"), posare il materiale ben distanziato dagli Elementi ad Elle e dai Gradini Continui, come mostrato nelle figure.
- Nel caso di terrazze o balconi, assicurarsi che le eventuali grondaie siano un sistema a sé stante, cioè siano ben distaccate dagli Elementi ad Elle o dai Gradini Continui.

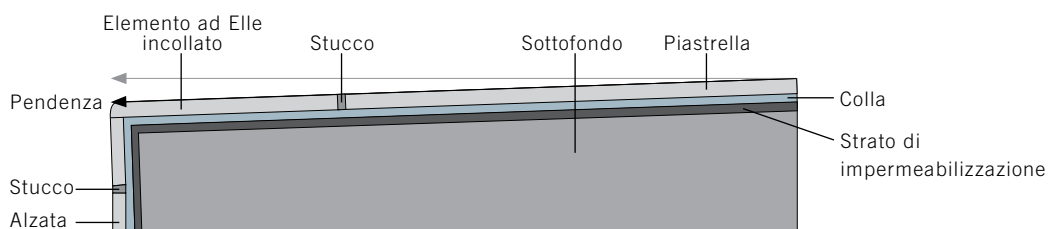
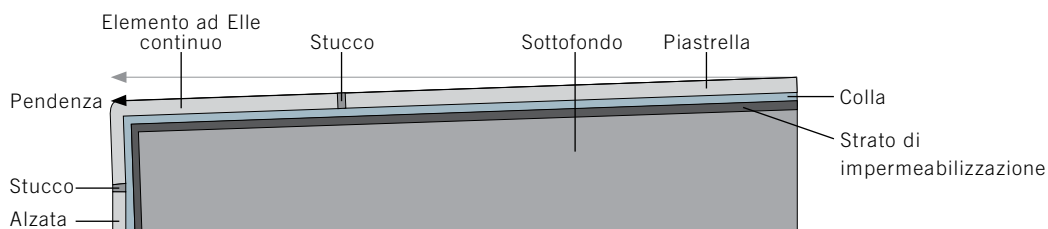
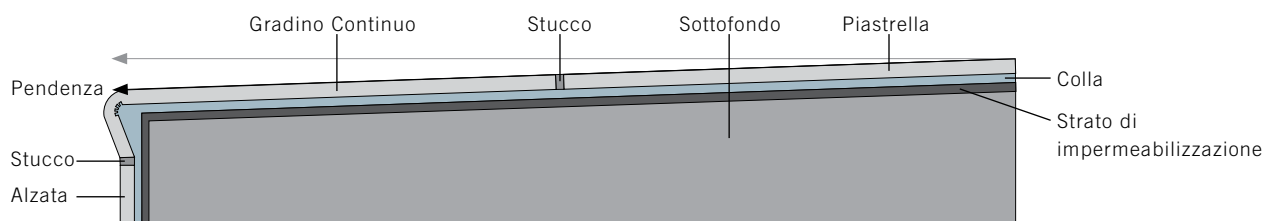

Laying of Elle Shaped element and Continued Step

Always lay using adhesive. All steps are intended as "indoor use" only.

When laying on cement bases use elastic class S2 EN 12004 compliant adhesive. When laying on other bases (e.g. wood, chipboard, ...) contact suppliers for the choice of the best adhesive.

Check that the base is stable, flat and clean. Cement layers (screed, concrete, levelling/sloping layers, ...) must be seasoned, that is must have withdrawn completely.

Avoid any water on the base. If flooring in use is in contact with water (exteriors, wellness centres, showers, changing rooms, ...) you need to:

- Create bases with a slope of at least 1% (1 cm for each metre)
- Apply suitable waterproofing to the base
- Mix the stucco with suitable latexes to reduce porosity of fugues.

DO NOT LEAVE EMPTY SPACES under the Elle-shaped elements and Continuous Step; lay by "double spreading" even for vertical parts.

The vertical parts of Elle-shaped Elements and Continuous Step must be spaced a few mm (at least 3-4 mm) from the base and the empty space must be filled with glue, see pictures.

Walk on the Elle-shaped Elements/Continuous Step and only fill fugues when the adhesive holds following manufacturer instructions.

Always lay with fugues of the right size, calculated by the designer.

Plan for perimeter joints in flooring coming into contact with vertical structural elements (walls, columns...) and suitable expansion joints.

Avoid rigid systems:

- If you want to cover the vertical part of steps ("rise"), lay the material the right distance from the Elle-shaped elements and Continuous Step, as shown in the pictures.
- For terraces and balconies, makes sure any gutters are a system to themselves; that is are well separated from the Elle-shaped Elements or Continuous Step.

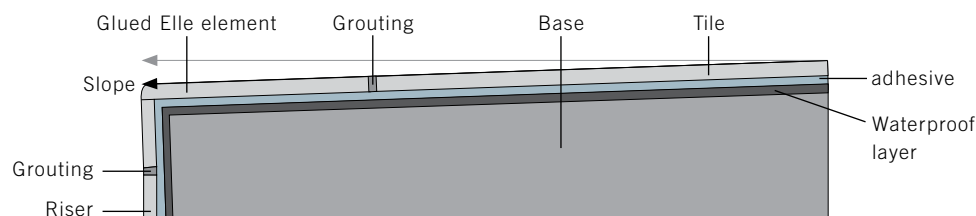
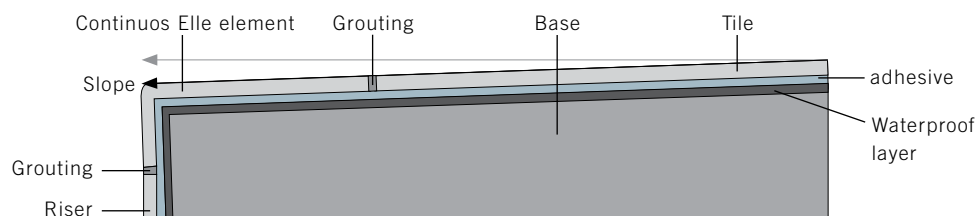
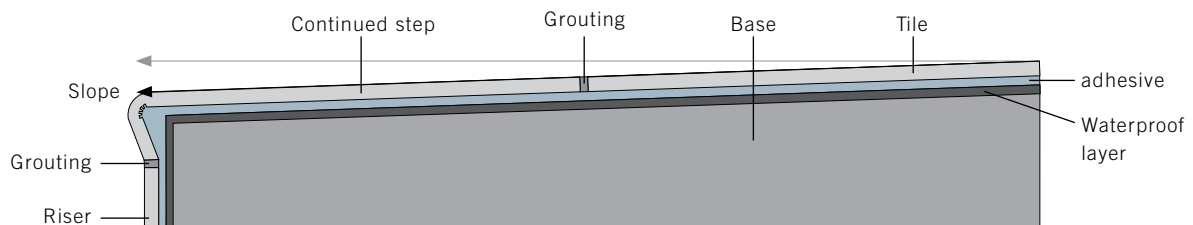

Pose d'Élément à Elle et nez Marche Continu

Effectuer toujours la pose avec de la colle. Tous les nez de marche sont à utiliser exclusivement à l'intérieur.

Pour la pose sur les sous-couches en ciment, utiliser des colles élastiques de classe S2 conformes à la norme EN 12004. En cas de pose sur d'autres supports (ex. bois, mélaminé ...), contacter les fournisseurs pour le choix de la colle la plus appropriée.

Vérifier que la sous-couche est stable, plane et propre. Les temps de séchage du support (chapes, béton armé, produits de ragréage ...) doivent être parfaitement respectés c'est-à-dire que les phénomènes de retrait doivent être terminés.

Éviter la présence d'eau sur la sous-couche. Si le sol à carrelé doit entrer en contact avec l'eau (pose en extérieur, centres bien-être, douches, vestiaires ...) il est nécessaire :

- de réaliser une sous-couche avec une pente d'au moins 1% (1 cm/mètre)
- d'appliquer des imperméabilisants appropriés sur la sous-couche
- de gâcher les mortiers avec des latex appropriés qui réduisent la porosité des jointoiments.

NE PAS LAISSER DE VIDES sous les éléments en Elle et les marche continues ; appliquer la colle avec la technique du double encollage (support et envers des carreaux), ainsi que sur le bord vertical des carreaux.

Le bord vertical des éléments en Elle et des marche continues doit être à une distance de quelques mm (au moins 3-4 mm) de la sous-couche et l'espace vide doit être rempli avec de la colle, voir les figures.

Ne piétiner les éléments en Elle et les marche continues et ne remplir les joints que lorsque la colle a déjà fait prise, selon les indications fournies par les fabricants.

Poser toujours avec un joint dont les dimensions seront calculées par le projeteur.

Prévoir sur le carrelage des joints périphériques aux points de contact avec les éléments structurels verticaux (mur, colonnes ...) et des joints de dilatation opportuns.

Éviter les systèmes rigides :

- si l'on désire carrelé la partie verticale des marches (contre-marche), poser les carreaux à une certaine distance des éléments en Elle et des marche continues comme le montrent les figures.
- Pour les terrasses et les balcons, s'assurer que gouttières sont totalement indépendantes, c'est-à-dire bien séparées des éléments en Elle ou des marche continues.

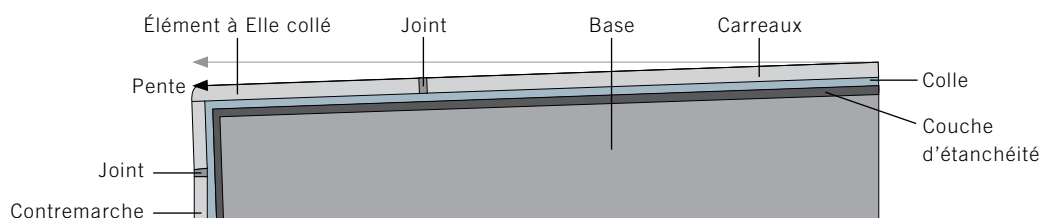
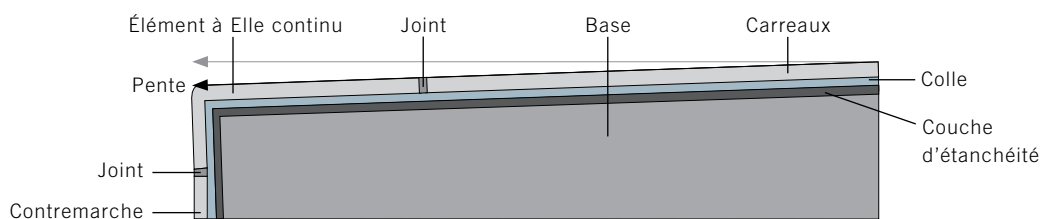
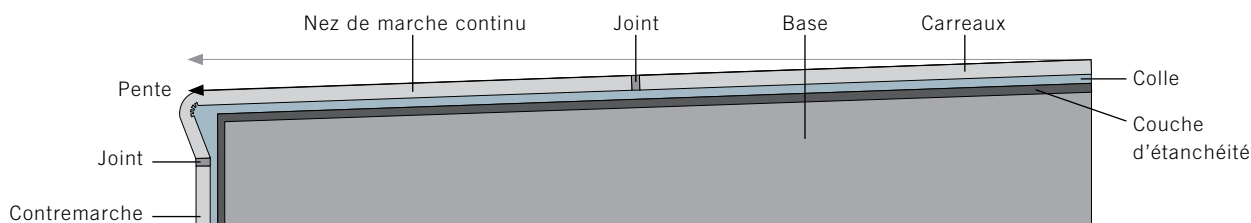

Verlegung des Elle-Elements und der Durchgehenden Stufen

Zum Verlegen immer Kleber verwenden. Alle Stufenplatten sind ausschließlich für die Verlegung im Innenbereich geeignet.

Zum Verlegen auf zementhaltigem Untergrund elastische Kleber der Klasse S2 gemäß EN 12004 verwenden. Wenden Sie sich beim Verlegen auf anderen Unterlagen (z.B. Holz, Spanplatten usw.) für die Wahl des geeigneten Klebers an die Händler.

Prüfen Sie, dass der Verlegeuntergrund stabil, eben und sauber ist. Die zementhaltigen Schichten (Estrich, Betonuntergrund, Nivellierschicht bzw. Gefälle, usw.) müssen abgelagert sein, d.h. die Schrumpfung muss abgeschlossen sein.

Es darf sich kein Wasser auf dem Untergrund befinden. Sollte der zu verlegende Fußboden in Kontakt mit Wasser gelangen (Außenbereiche, Wellness-Center, Duschen, Umkleieräume usw.) ist Folgendes zu beachten:

- Den Verlegeuntergrund mit einer Neigung von mindestens 1% erstellen (1 cm pro Meter)
- Geeignete Dichtstoffe auf der Oberfläche des Untergrunds anbringen
- Die Gipsmörtel mit einem geeigneten Latex mischen, um die Durchlässigkeit der Fugen zu verringern.

KEINE LEERRÄUME unter den L-Elementen und den Stufe aus einem StückHINTERLASSEN; auch den vertikalen Abschnitt der Elemente mit "Doppelbeschichtung" verlegen.

Die vertikale Kante der L-Elemente und der Stufe aus einem Stückmuss einige mm Abstand (mind. 3-4 mm) zum Verlegeuntergrund aufweisen; dabei ist der Leerraum mit Kleber zu füllen, siehe Abbildungen.

Die L-Elemente/Stufe aus einem Stückbetreten und die Fugen erst verschließen, nachdem der Kleber entsprechend der Herstellerangaben gehärtet ist.

Immer mit der Fuge verlegen, wobei deren Größe, die vom Projektplaner berechnet wird, angemessen sein muss.

Kalkulieren Sie bei der Fußbodenverlegung die umlaufenden Fugen, welche mit vertikalen Konstruktionselementen (Mauern, Säulen, usw.) in Kontakt stehen, sowie die Dehnungsfugen mit ein.

Vermeiden Sie starre Systeme:

- Bei der Verkleidung des vertikalen Abschnitts der Stufen ("Setzstufe") das Material in einem angemessenen Abstand zu den L-Elementen und den Stufe aus einem Stückverlegen, siehe Abbildungen.
- Bei Terrassen oder Balkons sicherstellen, dass die evtl. vorhandenen Dachrinnen ein unabhängiges System darstellen, d.h. einen angemessenen Abstand zu den L-Elementen und den Stufe aus einem Stückaufweisen.

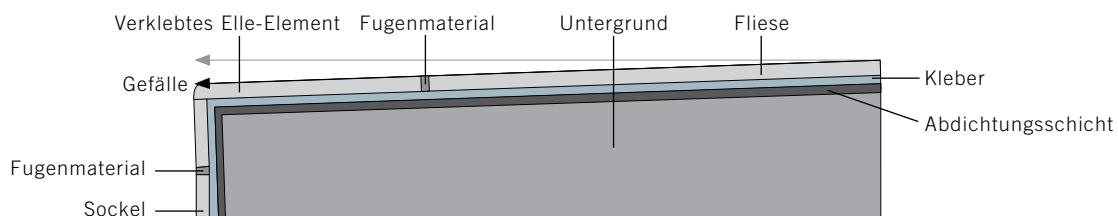
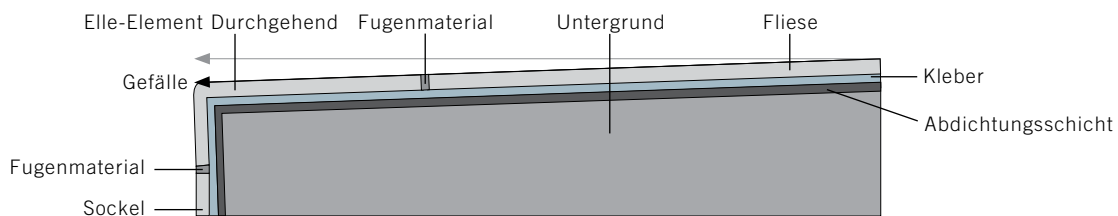
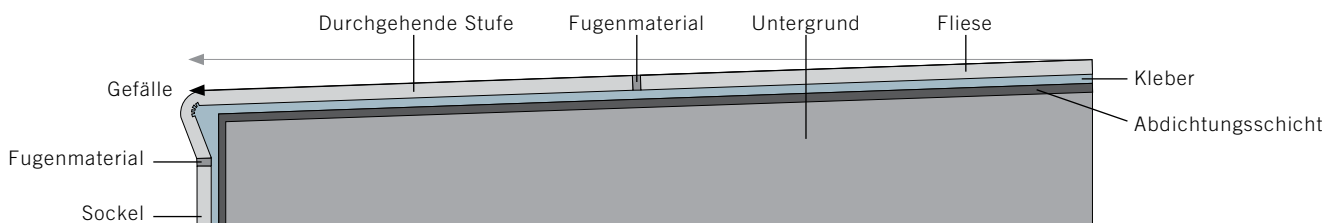

Colocación Elemento Elle y Peldaños Continuos

Realice siempre la colocación con adhesivo. Todos los peldaños/huella son para colocación exclusivamente en interior.

Para la colocación sobre bases de cemento use adhesivos elásticos de clase S2 según EN 12004. En caso de colocación sobre otros soportes (por ej. madera, aglomerado, etc.) contacte con los proveedores para elegir el adhesivo más apropiado.

Controle que la base esté estable, plana y limpia. Las capas de cemento (soleras, hormigón, capas de nivelación/pendiente, etc.) deben estar secadas, o sea, haber terminado los fenómenos de contracción.

Evite la presencia de agua en la base. Si la pavimentación que se está trabajando va a estar en contacto con el agua (ambientes exteriores, centros de bienestar, duchas, vestuarios, etc.) es necesario:

- Realizar bases con una pendiente de al menos 1% (1 cm por cada metro).
- Aplicar impermeabilizantes adecuados sobre la superficie de la base.
- Mezclar los materiales de rejuntado con látex adecuados que reduzcan la porosidad de las juntas.

NO DEJE ESPACIOS VACÍOS debajo de los Elementos en L y de los Peldaños doblados, coloque con “doble encolado” también en la parte vertical de las piezas.

El borde vertical de los Elementos en L y de los Peldaños doblados debe estar separado de algunos mm (por lo menos 3-4 mm) de la base y el espacio vacío se debe llenar con cola, vea las figuras.

Pise los Elementos en L/Peldaños doblados y llene las juntas sólo cuando el adhesivo haya fraguado, según las indicaciones de los fabricantes.

Haga la colocación siempre con la junta, que debe tener dimensiones apropiadas y ser calculada por el diseñador.

En la pavimentación prevea las juntas perimetrales en contacto con los elementos estructurales verticales (muros, columnas...) y adecuadas juntas de dilatación.

Evite sistemas rígidos:

- Si desea revestir la parte vertical de los peldaños (“contrahuella”) coloque el material bien separado de los Elementos en L y de los Peldaños doblados como se muestra en las figuras.
- En caso de terrazas o balcones, asegúrese de que los eventuales canalones formen un sistema por sí mismos, o sea, que estén bien separados de los Elementos en L o de los Peldaños doblados.

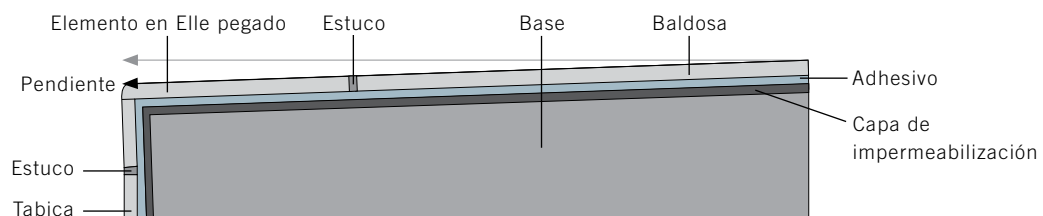
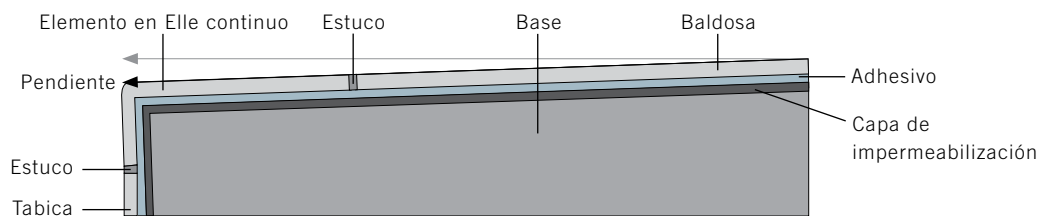
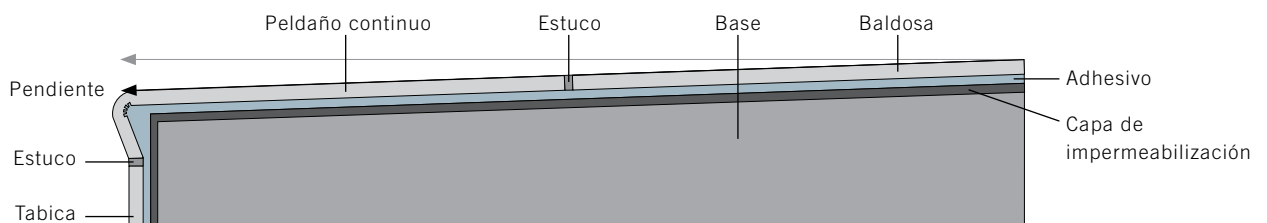

Informazioni per la pulizia e la manutenzione

Prima di pulire una superficie piastrellata è bene:

1. Verificare sul catalogo generale la **resistenza agli agenti chimici** delle piastrelle posate;
2. Effettuare un test preliminare direttamente sulle piastrelle posate, ponendo il detergente da utilizzare a contatto con le piastrelle per tempi uguali a quelli che si useranno poi sul cantiere;
3. Assicurarsi che i detersivi da usare **non contengano** acido fluoridrico e/o suoi derivati, poiché tali sostanze, per loro peculiarità, aggrediscono tutti i prodotti ceramici.

Si riportano di seguito alcune indicazioni per le pulizie di fine cantiere (“dopo posa”), quotidiane, straordinarie, per la rimozione di cere e patine lucidanti e per eventuali manutenzioni straordinarie.

Pulizia “dopo posa”

1. La pulizia “dopo posa” serve per rimuovere i residui di stucchi per le fughe, cemento, calce, boiaccia. E’ obbligatoria a fine cantiere, sia per le piastrelle smaltate che per quelle non smaltate.
2. Una pulizia “dopo posa” male effettuata, o addirittura non fatta, è spesso causa di aloni che impediscono di mantenere pulito il pavimento nonostante una buona pulizia quotidiana.
3. Quando possibile, specialmente per superfici medio-grandi, si consiglia l’uso di monospazzola con dischi morbidi (bianchi oppure beige).

4. Pulizia stucchi cementizi miscelati con acqua

Si effettua con specifici detersivi a base di acidi tamponati e diluiti. Alcuni di questi, facilmente reperibili in commercio, sono riportati nella seguente tabella.

residuo da rimuovere	tipo di detergente	nome detersivi	produttore
stucchi cementizi boiaccia cemento calce	a base di acidi tamponati	keranet	mapei
		cement remover	faberchimica
		deterdek	fila
		trek	kiter
		zementschleierentferner	lothofin
		hmk r63	hmk
		solvacid	geal
		bonaclean	bonasystems italia
		bonadecon(*)	bonasystems italia

Salvo diversa indicazione di LEA CERAMICHE, seguire attentamente le modalità d’uso indicate sulle confezioni dai fabbricanti.
(*) Specifico per prodotti non resistenti agli acidi.

Indicazioni per la pulizia “dopo posa”:

1. Effettuare la pulizia dopo 4-5 giorni dalla stuccatura (lo stucco deve indurire) e non oltre 10 giorni. Oltre questi tempi la pulizia può diventare molto più laboriosa.
2. Bagnare con acqua il pavimento prima delle operazioni di pulizia. In questo modo le stucature vengono impregnate dall’acqua e viene ridotto il contatto con i detersivi.
3. Lasciare agire i detersivi per tempi limitati, risciacquando bene con acqua appena possibile.
4. Non deve essere eseguita se le superfici piastrellate sono molto calde (es. esposte al sole nei mesi più caldi), perché diviene più severa l’azione degli aggressivi chimici. In estate effettuarla nelle ore fresche della giornata.
5. Fare sempre test preventivi prima dell’uso (su una piastrella non posata), in particolare per prodotti Lappati o Levigati.

5. pulizia stucchi epossidici, bi-componenti e reattivi

In questi casi la rimozione dei residui degli stucchi deve essere fatta immediatamente ed in modo molto accurato seguendo le indicazioni dei fabbricanti, perché questi stucchi induriscono molto rapidamente, anche in pochi minuti. Seguire attentamente le modalità di pulizia indicate dal fabbricante dello stucco utilizzato e verificarne l’efficacia (anche controlluce!) con una prova preliminare di pulizia prima di stuccare l’intero pavimento/parete.

6. piastrelle antiscivolo

Le piastrelle “antislip”, realizzate con superfici ruvide e/o strutturate, si puliscono ovviamente in modo più laborioso. Si consiglia perciò di effettuare la pulizia “dopo posa” in modo rapido ed accurato, utilizzando quando possibile monospazzola con dischi bianchi e beige.

Pulizia straordinaria

Viene effettuata per rimuovere macchie o residui particolarmente vecchi o resistenti. Prima dell'uso fare sempre test preventivi (su una piastrella non posata), in particolare su **Lappati e Levigati**.

Nella tabella sotto sono indicati detergenti efficaci a seconda del tipo di macchia.

residuo da rimuovere	tipo di detergente	nome detergenti	produttore
grassi polvere da calpestio pulizie di fondo	polifunzionali, a base alcalina (1)	ps87	fila
		intensivreiniger	lithofin
		hmk r55	hmk
		taski r20-strip	johnsondiversey
		bonamain	bonasystems italia
		bonadecon	bonasystems italia
caffè coca-cola succhi di frutta	polifunzionali, a base alcalina(1)	coloured stain remover	faberchimica
		ps87	fila
vino	ossidante	oxidant	faberchimica
depositi calcarei	a base acida (1)	viakal acido muriatico diluito	procter & gamble vari produttori
ruggine	a base acida (1)	acido muriatico diluito	vari produttori
inchiostri pennarello	a base solvente	diluyente nitro, dielina, acqua ragia	vari produttori
		coloured stain remover	faberchimica
pneumatici, segni di gomma di metalli di matita	pasta abrasiva	vim clorex (2)	guaber
		polishing cream (2)	faberchimica
		strong remover (3)	faberchimica
		detergum (3)	zep italia
sporco delle fughe	specifico	fuganet	fila
		fugenreiniger	lithofin

(1) Fare test preventivo su materiali Lappati e Levigati

(2) Indicato per materiali Lappati e Levigati

(3) Non usare su prodotti Lappati, usare con molta attenzione sui Levigati

Salvo diversa indicazione di LEA CERAMICHE, seguire attentamente le modalità d'uso indicate sulle confezioni dai fabbricanti.

Informazioni per la pulizia e la manutenzione

Pulizia quotidiana / ordinaria

Utilizzare detergenti neutri, diluiti in acqua calda, che **non contengono cere** o **non depositino patine lucide**, asportando le acque di lavaggio con panno in **microfibra**. Risciacquare bene con acqua a fine lavaggio, asportando le acque di lavaggio con un secondo panno in **microfibra**. Si consigliano i seguenti prodotti reperibili in commercio.

tipo di operazione	tipo di detergente	nome detergenti	produttore
pulizie quotidiane	neutro	floor cleaner	faberchimica
		fila cleaner	fila
		pflegereiniger	lithofin
		hmk p15	hmk
		bonamain plus	bonasystems italia

Salvo diversa indicazione di LEA CERAMICHE, seguire attentamente le modalità d'uso indicate sulle confezioni dai fabbricanti.

Pulizia decori

- Utilizzare detergenti NEUTRI e diluiti, alcool.
- NON UTILIZZARE ASSOLUTAMENTE**
- Detergenti acidi o alcalini
- Paste abrasive (Detergum, StrngRemover, Polishing Cream, Vim Clorex, etc.)
- Spazzole o spugne abrasive.

Rimozione di patine lucide

Nei normali detergenti in commercio sono a volte contenute cere o additivi lucidanti che, lavaggio dopo lavaggio, depositano sul pavimento **patine lucide**, causa di noiose alonature. Patine di questo tipo possono essere depositate anche da alcuni stucchi per le fughe.

Semplici alimenti come Coca Cola, Vino, acqua, etc., cadendo sul pavimento tolgono questa patina lucida e ripristinano l'**aspetto originale** più opaco delle piastrelle. In mezzo al pavimento più lucido, le zone senza cera appaiono come aloni opachi, in realtà sono le uniche parti pulite del pavimento. In questi casi bisogna:

1. Prima di tutto togliere la patina lucida da tutto il pavimento (vedi tabella seguente);
2. Poi, per le pulizie quotidiane, utilizzare detergenti neutri che non contengano né cere né patine lucidanti (vedi paragrafo precedente "pulizie quotidiane/ordinarie").

residuo da rimuovere	tipo di detergente	nome detergenti	produttore
patine lucide	debolmente acidulo	tile cleaner puro (*)	faberchimica
		bonadecon puro (*)	bonasystems italia

(*) Non seguire le indicazioni sulla confezione, ma applicare il detergente puro, lasciare agire per 5-10 minuti, frizionare con tamponi morbidi (bianco, giallo) e sciacquare bene con acqua.

Non utilizzare cere su gres porcellanato LEA CERAMICHE.

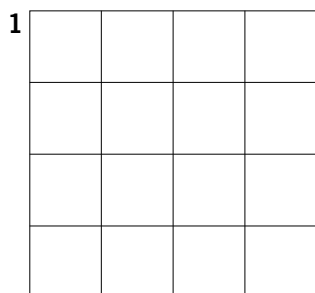

Pavimento originale.

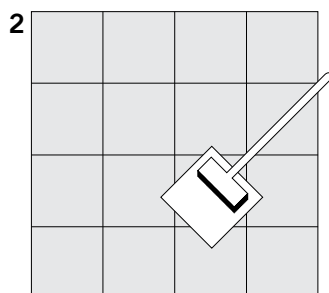

Dopo pulizia con detergenti contenenti cere.

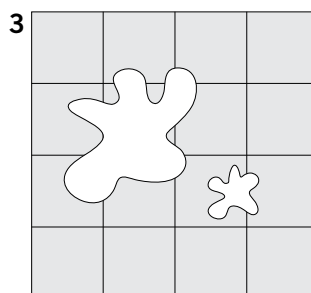

Semplici alimenti (Coca-Cola, vino, acqua...) possono togliere la patina lucida. La superficie originale è più opaca.

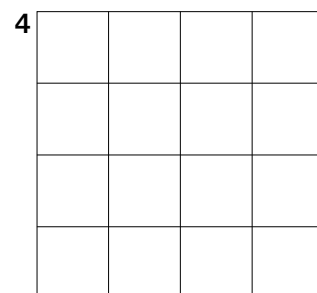

Rimuovere la patina con detergente (Tile Cleaner puro, Faber) ed utilizzare quotidianamente un detergente senza cere.

Manutenzioni straordinarie

protettivi per gres levigato

Per facilitare la pulizia del Gres Levigato LEA CERAMICHE si possono applicare i seguenti prodotti.

nome prodotto	produttore
mp 90	fila
gres lux 90	faber chimica
keraseal	federchemicals

Salvo diversa indicazione di LEA CERAMICHE, seguire attentamente le modalità d'uso indicate sulle confezioni dai fabbricanti. Effettuare sempre un test preventivo per verificare i tempi di asciugatura e di calpestabilità del pavimento.

protettivi per fughe

nome prodotto	produttore
fugaproof	fila
kf fugenschutz	lithofin

Salvo diversa indicazione di LEA CERAMICHE, seguire attentamente le modalità d'uso indicate sulle confezioni dai fabbricanti.

trattamenti antislip

La resistenza allo scivolamento dei pavimenti posati (sia piastrelle smaltate che non smaltate) può essere aumentata utilizzando specifici prodotti (vedi tabella).

Prima di applicare il prodotto sul pavimento fare test preventivi su piastrelle non posate per trovare i tempi di contatto più idonei. Se da un lato tempi più lunghi aumentano il grado di grip, dall'altro tendono un po' a sbiancare i colori delle piastrelle e a renderle un pochino più sporcabili.

tipo di operazione	nome prodotto	produttore
trattamento antislip	safe floor	faberchimica
	safe floor/30	faberchimica
	bonagrip	bonasystems italia

attenzione:

1. Non usare questi trattamenti su superfici Lappate né Levigate;
2. Prima del trattamento contattare Servizio Clienti Lea;
3. Si consiglia di realizzare il trattamento tramite ditte specializzate.

I prodotti **LEVIGATI** possono raggiungere il grado **R9** (test DIN51130) con appositi trattamenti al laser, eseguibili solo sul materiale non posato: per questo la richiesta di R9 su Levigati deve essere specificata al momento dell'ordine all'ufficio commerciale.

Tali trattamenti al laser possono essere seguiti anche su superfici **LAPPATE** (dopo verifica Servizio Clienti LEA CERAMICHE).

Riferimenti utili pag. 424

cleaning and maintenance information

Make sure to do the following before cleaning any tiled surface:

1. Check the **resistance to chemical agents** of the laid tiles on the general catalogue;
2. Make a preliminary test directly on the laid tiles by putting a detergent, to be used in contact with the tiles for a period that is equal to the period that will be used later on the site;
3. Make sure that the detergents that are going to be used, **do not contain** hydrofluoric acid and/or any of its derivatives; these substances are distinctively known for damaging **all** ceramic products.

Some indications for cleaning after the installation (after laying the tiles), on a daily basis, extra cleaning and to remove waxes and polish glazes or for any extra maintenance that may be required, are listed here below.

cleaning “after the installation”

1. Cleaning “after the installation” helps remove residues of grout-joints, cement and lime. This is **obligatory** at the end of the installation, for glazed tiles and unglazed tiles.
2. If the cleaning “after the installation” is not carried out properly or if is not carried out at all, is often a cause of marks that prevent the floor from being clean even if a good daily cleaning is performed.
3. Whenever is possible, especially for medium to large surfaces, it is advisable to use a single-brush machine with soft disks (white or beige).

4. cleaning cement-based grouts mixed with water.

It is carried out with specific detergents based with buffered and diluted acids. The table below shows some of these detergents, which are easily available in the market.

for removing the following residues	type of detergent	detergent's name	manufacturer
cement-based grouts grout cement lime	buffered acid based	keranet	mapei
		cement remover	faberchimica
		deterdek	fila
		trek	kiter
		zementschleierentferner	lothofin
		hmk r63	hmk
		solvacid	geal
		bonaclean	bonasystems italia
		bonadecon(*)	bonasystems italia

Unless otherwise indicated by LEA CERAMICHE, follow the instructions indicated on the manufacturer's package very carefully.
(*) Specific for products that are non-resistant to acids

Unless otherwise indicated by LEA CERAMICHE, follow the instructions indicated on the manufacturer's package very carefully.

Instructions on how to clean “after the installation”:

1. Clean 4-5 days after the grouting (the grout must be hardened); do not wait over 10 days. In addition to this period, the cleaning can become very laborious.
2. Moisten the floor with water before cleaning. This way the groutings are soaked with water and the contact with detergents is reduced.
3. Let the detergents operate for limited periods, hence rinse out with water as soon as possible.
4. It must not be carried out if the tiled surfaces are very hot (i.e. exposed to the sun during very warm days); this must be avoided as the action of aggressive chemicals become very harsh. On the summer, proceed with the operation during the coolest period of the day.
5. Make sure to always perform a precautionary test before using the product (on a tile that is not laid), especially for Lapped or Polished products.

5. cleaning for epoxy, bi-component and reagent grouts

In these cases the removal must be carried out immediately and carefully following the recommendations of the manufacturers, as these grouts harden very fastly, even in a few minutes. Please carefully follow the cleaning mode specified by the manufacturer of the grout used; verify its effectiveness (backlight also) with a preliminary cleaning test before grouting the entire floor/wall.

6. antislip tiles

“Antislip” tiles that are made with rough and/or textured surfaces must be cleaned very laboriously. Therefore, it is advisable to clean “after the installation”, quickly and thoroughly, using a single-brush machine with disks white and beige.

Extraordinary cleaning

This procedure is carried out to remove stains or residues that are particularly old or tough. Make sure to always perform a precautionary test before using the product (on a tile that is not laid), especially for **Lapped** or **Polished** products.

The table shown below indicates the detergents that are effective according to the type of stains.

for removing the following residues	type of detergent	detergent's name	manufacturer
grease dust footmarks base cleaning	multipurpose, alkaline-based (1)	ps87	fila
		intensivreiniger	lithofin
		hmk r55	hmk
		taski r20-strip	johnsondiversey
		bonamain	bonasystem italia
		bonadecon	bonasystem italia
coffee coke fruit juice	multipurpose, alkaline-based (1)	coloured stain remover	faberchimica
		ps87	fila
wine	oxidizing agent	oxidant	faberchimica
calcareous deposits	acid-based (1)	viakal dilute hydrochloric acid	procter & gamble various manufactures
rust	acid-based (1)	dilute hydrochloric acid	various manufactures
inks felt-tipped pen	solvent-based	nitro thinner, dichloroethylene, turpentine	different manufacturers
		coloured stain remover	faberchimica
pneumatic stains from rubber metals or pencils	abrasive paste	vim clorex (2)	guaber
		polishing cream (2)	faberchimica
		strong remover (3)	faberchimica
		detergum (3)	zep italia
tile joint stains	specific	fuganet	fila
		fugenreiniger	lithofin

(1) Make precautionary test on Lapped or Polished materials

(2) Suitable for Lapped or Polished materials

(3) Do not use it on Lapped; use it with the utmost caution on Polished products

Unless otherwise indicated by LEA CERAMICHE, follow the usage instructions indicated on the manufacturer's package very carefully.

cleaning and maintenance information

Daily / standard cleaning

Use neutral detergents, diluted in warm water, that **do not contain waxes** and **do not leave shiny patinas**. Wipe off the water with a **microfiber** cloth. Rinse with water once cleaned and clean off the water using another **microfiber** cloth. We recommend the following products that are regularly distributed.

type of operation	type of detergent	detergent's name	manufacturer
clean on a daily basis	neutral	floor cleaner	faberchimica
		fila cleaner	fila
		pflgereiniger	lithofin
		hmk p15	hmk
		bonamain plus	bonasystems italia

Unless otherwise indicated by LEA CERAMICHE, follow the instructions indicated on the manufacturer's package very carefully.

Cleaning decorations

- Use NEUTRAL, diluted, alcohol-based detergents
- NEVER USE**
- Acid or alkaline detergents
- Abrasive pastes (Detergum, StrngRemover, Polishing Cream, Vim Clorox, etc.)
- Abrasive brushes or sponges.

Removing glossy glaze

Standard detergents that are available in the market sometimes contain waxes or polish additives that, wash after wash, deposit **glossy glaze** on the floor and causes annoying marks. These types of glazes can also settle on some joint grouts.

When simply types of foods such as Coke, Wine, water, etc., fall on the floor, they remove this type of glossy glaze and restore the **original appearance** of the tiles (a more opaque look). In the middle of the shinier floor, the areas without wax appear as opaque marks, but they are actually the only clean parts of the floor. In these cases, the following must be done:

1. First of all, remove the glossy glaze from the entire floor (see table below);
2. Then, for daily cleaning, use neutral detergents that do not contain wax or polishing glaze (see the previous paragraph: "daily/standard cleaning").

residues to be removed	type of detergent	detergent's name	manufacturer
glossy glaze	weak acidulous	tile cleaner pure (*)	faberchimica
		bonadecon pure (*)	bonasystems italia

(*) Do not follow the instructions on the package, just apply the pure detergent, leave it on for 5-10 minutes, rub it with soft pads (white, yellow) and rinse it thoroughly with water.

Do not use wax on LEA CERAMICHE porcelain stoneware.

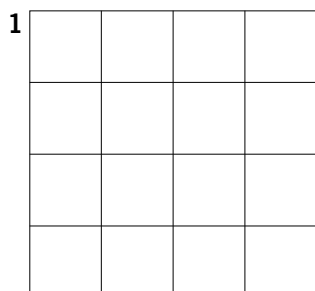

Original floor.

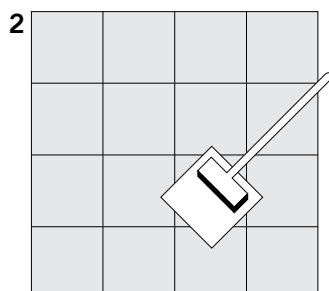

After cleaning detergents containing waxes.

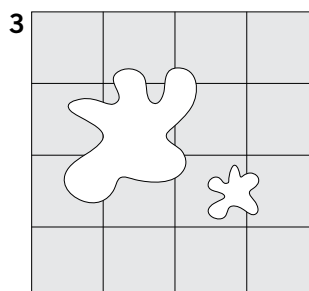

Simple foodstuffs (Coca-Cola, wine, water etc) can remove the bright patina. The original surface is more matt.

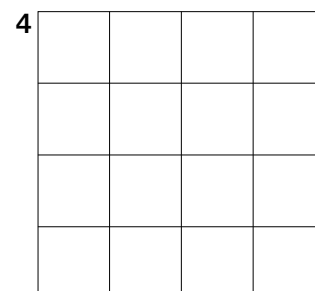

Remove the patina with detergent (Faber tile cleaner, used neat), and use detergent without waxes for everyday cleaning.

Special maintenance

stain-resistant products for polished porcelain stoneware

To make the cleaning of LEA CERAMICHE Polished Porcelain Stoneware easier, the following products may be used.

product name	manufacturer
mp 90	fila
gres lux 90	faber chimica
keraseal	federchemicals

Unless otherwise indicated by LEA CERAMICHE, follow the instructions indicated on the manufacturer's package very carefully.

Make sure to always carry out a precautionary test to check the drying time and the time required before it is possible to walk on the treated floor.

stain-resistant products for joints

product name	manufacturer
fugaproof	fila
kf fugenschutz	lithofin

Unless otherwise indicated by LEA CERAMICHE, follow the instructions indicated on the manufacturer's package very carefully.

antislip treatments

The slip resistance of floors laid with glazed tiles or non-glazed tiles can be increased by using specific products (see table).

Before applying the product make a precautionary test on a tile that is not laid in order to find the most suitable contact time. If, on the one hand, the longest period increases the gripping grade, on the other, it will tend to whiten the colours of the tiles a little and make it a little easier to stain.

type of operation	product name	manufacturer
antislip treatment	safe floor	faberchimica
	safe floor/30	faberchimica
	bonagrip	bonasystems italia

caution:

1. Do not use these treatments on Lapped or Polished surfaces;
2. Before the doing the treatment contact Lea's Customer Service;
3. It is advisable to carry out the treatments through specialized companies.

POLISHED products can reach a grade of **R9** (test DIN51130) with special laser treatments that may be carried out only on materials that have **not been laid**: for this reason the request for R9 on Polished products must be specified at the time of the order in the sales department.

Such laser treatments can be also be carried out on **LAPPED** surfaces (after making a verification with LEA CERAMICHE Customer Service).

Useful contacts pag. 424

Informations sur le nettoyage et l'entretien

Avant de nettoyer une surface carrelée, il est préférable de :

1. Vérifier la **résistance chimique** des carreaux posés sur le catalogue général ;
2. Faire un test avant emploi en versant le nettoyant directement sur les carreaux installés et en le laissant agir aussi longtemps que la durée prévue sur le chantier;
3. S'assurer que les nettoyants **ne contiennent** ni acide fluorhydrique ni aucun de ses dérivés, car ces substances particulières entament **tous** les produits céramiques.

Veuillez trouver ci-après quelques instructions pour bien effectuer les nettoyages de fin de chantier (« après pose »), quotidiens, extraordinaires, pour éliminer les cires et les additifs de cirage et pour réaliser toute opération d'entretien extraordinaire.

nettoyage « après pose »

1. Le nettoyage « après pose » sert à enlever les résidus de mortier, de ciment, de chaux et de ciment-joint. Il est **obligatoire** à la fin du chantier, aussi bien pour les carreaux émaillés que pour les carreaux non émaillés.
2. Un mauvais nettoyage « après pose », voire même l'absence de nettoyage, entraîne souvent la formation d'auréoles qui compromettent la propreté du revêtement de sol, même après un bon nettoyage quotidien.
3. Chaque fois que possible, notamment pour les surfaces moyennes/grandes, il est recommandé d'avoir recours à une monobrosse munie des disques souples (blancs ou beige).

4. nettoyage ciments-joints mélangés avec de l'eau

Nettoyage avec des nettoyants spéciaux à base d'acides tamponnés et dilués. Veuillez trouver dans le tableau ci-après quelques noms de produits facilement trouvables dans le commerce.

résidu à enlever	type de nettoyant	nom des nettoyants	fabricant
ciments-joints ciment chaux	à base d'acides tamponnés	keranet	mapei
		cement remover	faberchimica
		deterdek	fila
		trek	kiter
		zementschleierentferner	lothofin
		hmk r63	hmk
		solvacid	geal
		bonaclean	bonasystems italia
		bonadecon(*)	bonasystems italia

Sauf indication contraire de LEA CERAMICHE, suivre avec soin le mode d'emploi signalé par le fabricant sur l'emballage.
(*) Spécifique pour produits qui ne sont pas résistants aux acides

Instructions de nettoyage « après pose » :

1. Nettoyer 4-5 jours après l'exécution des joints (le mortier doit durcir) et avant 10 jours maximum. Après ce délai, le nettoyage peut demander beaucoup plus d'efforts.
2. Mouiller le revêtement de sol avant les opérations de nettoyage. Ainsi l'eau imprègne les joints et atténue le contact avec les nettoyants.
3. Laisser agir les nettoyants peu de temps et bien rincer à l'eau dès que possible.
4. Ne pas faire le nettoyage si les surfaces carrelées sont très chaudes (par ex. exposées au soleil pendant les mois les plus chauds), car la chaleur renforce l'action agressive des produits chimiques. En été, il doit se faire aux heures fraîches de la journée.
5. Faire toujours des tests avant emploi (sur un carreau non posé), notamment sur les produits Rodés ou Polis.

5. nettoyage des joints epoxy, bi-composant et réactif

Nettoyer immédiatement les résidus de manière soignée en se conformant aux indications fournies par le fabricant car ce type de coulis durcit rapidement, même en quelques minutes. Suivez attentivement les indications de nettoyage indiqué par le fabricant de joint utilisé et vérifiez son efficacité (même rétroéclairage) avec un nettoyage préventif avant de jointoyer la totalité du sol / mur.

6. carreaux antidérapants

Les carreaux « antislip » à base de structures rugueuses et/ou structurées se nettoient évidemment moins facilement. Il est dès lors recommandé d'effectuer le nettoyage « après pose » de façon rapide et minutieuse et d'utiliser, si possible, une monobrosse à disques blancs ou beige.

nettoyage extraordinaire

Il sert à éliminer les taches ou les résidus particulièrement anciens ou tenaces. Faire toujours des tests avant emploi (sur un carreau non posé), notamment sur les produits **Rodés** et **Polis**.

Veillez trouver dans le tableau ci-après des nettoyeurs efficaces selon le type de tache.

résidu à enlever	type de nettoyant	nom des nettoyeurs	fabricant
graisses dépôts de poussières laissées par le piétinement grands nettoyages	alcalins universels (1)	ps87	fila
		intensivreiniger	lithofin
		hmk r55	hmk
		taski r20-strip	johnsondiversey
		bonamain	bonasystems italia
		bonadecon	bonasystems italia
café Coca-Cola jus de fruits	alcalins universels (1)	coloured stain remover	faberchimica
		ps87	fila
vin	oxydant	oxidant	faberchimica
dépôts calcaires	acide (1)	viakal acide muriatique dilué	procter & gamble fabricants diverse
rouille	acide (1)	acide muriatique dilué	fabricants diverse
encres feutre	à base de solvant	diluant nitro-cellulosique, dichloroéthylène, essence de térébenthine	
		coloured stain remover	faberchimica
pneus traces de caoutchouc de métaux de crayon	pâte abrasive	vim clorex (2)	guaber
		polishing cream (2)	faberchimica
		strong remover (3)	faberchimica
		detergum (3)	zep italia
sauté des joints	spécifique	fuganet	fila
		fugenreiniger	lithofin

(1) Faire des tests avant emploi sur les produits Rodés et Polis

(2) Recommandé pour les produits Rodés et Polis

(3) Ne pas utiliser sur les produits Rodés, utiliser sur les produits polis en faisant très attention

Sauf indication contraire de LEA CERAMICHE, suivre avec soin le mode d'emploi signalé par le fabricant sur l'emballage.

Informations sur le nettoyage et l'entretien

Nettoyage quotidien / ordinaire

Utilisez un détergent neutre dilué dans l'eau chaude, qui **ne contiennent pas de cires ou des produits qui lâchent des taches**, enlever l'eau de lavage avec un chiffon en **microfibres**. Rincer abondamment à l'eau à la fin du lavage, retirer l'eau de lavage avec un deuxième chiffon en **microfibres**. Nous recommandons les produits suivants disponibles sur le marché.

type d'opération	type de nettoyage	nom des nettoyeurs	fabricant
nettoyages quotidiens	neutre	floor cleaner	faberchimica
		fila cleaner	fila
		pflgereiniger	lithofin
		hmk p15	hmk
		bonamain plus	bonasystems italia

Sauf indication contraire de LEA CERAMICHE, suivre avec soin le mode d'emploi signalé par le fabricant sur l'emballage.

Nettoyage décors

- utiliser des détergents NEUTRES et dilués, de l'alcool.
- NE SURTOUT PAS UTILISER**
- Des détergents acides ou alcalins
- Des produits abrasifs (Detergum, StrngRemove, Polishing Cream, Vim Clorex, etc.)
- Des brosses ou des éponges abrasives.

Élimination des films brillants

Les nettoyeurs ordinaires disponibles dans le commerce contiennent souvent des cires ou des additifs de cirage qui, lavage après lavage, déposent sur le revêtement de sol des **films brillants** qui entraînent la formation d'auréoles difficiles à éliminer. Des films de ce genre peuvent aussi être occasionnés par certains mortiers.

Si des simples boissons, comme le Coca-Cola, le vin, l'eau, etc., sont renversées sur le sol, ce film brillant part et les carreaux reprennent leur **aspect original** plus mat. À côté des carreaux plus brillants, les zones sans cire ont l'air d'être des sortes d'auréoles mates, alors qu'en fait, ce sont les seules parties propres du revêtement de sol.

Dans ce cas, il faut :

1. avant toute chose, éliminer le film brillant sur l'ensemble du revêtement de sol (voir tableau ci-après) ;
2. ensuite, pour les nettoyages quotidiens, utiliser des nettoyeurs neutres qui ne contiennent ni cire ni additif de cirage (voir paragraphe précédent « nettoyages quotidiens/ordinaires »).

résidu à enlever	type de nettoyeur	nom des nettoyeurs	fabricant
films brillants	légèrement acide	tile cleaner pur (*)	faberchimica
		bonadecon pur (*)	bonasystems italia

(*) Ne pas suivre le mode d'emploi signalé sur l'emballage, mais utiliser le nettoyeur pur, laisser agir 5-10 minutes, frotter avec des disques tampons doux (blanc, jaune) et bien rincer à l'eau.

Nes pas utiliser de cires sur le grès cérame LEA CERAMICHE.

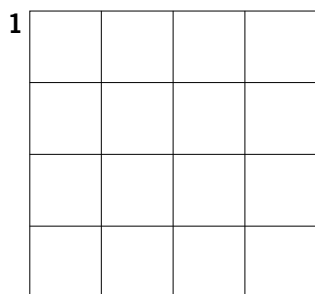

Sol original.

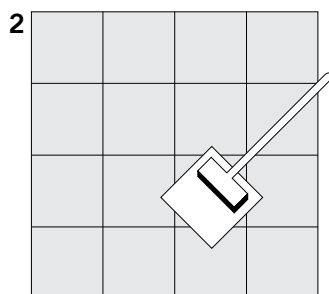

Après un nettoyage avec détergents contenant de la cire.

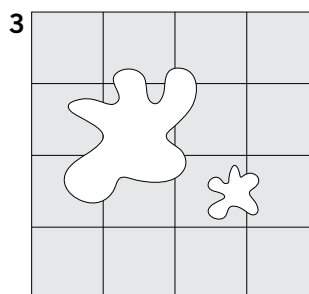

Certains aliments (Coca-Cola, vin, eau, etc.) peuvent enlever la patine brillante. La surface originelle est plus opaque.

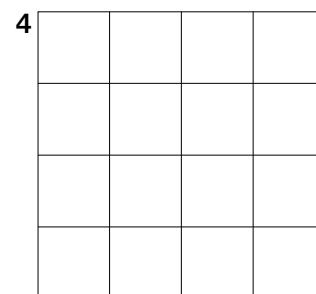

Retirer la patine à l'aide d'un détergent (Tile Cleaner pur de Faber) et utiliser chaque jour un détergent sans cire.

Entretiens extraordinaires

protection grès poli

Pour faciliter le nettoyage du Grès Poli LEA CERAMICHE, les produits suivants peuvent être utilisés.

nom du produit	fabricant
mp 90	fila
gres lux 90	faber chimica
keraseal	federchemicals

Sauf indication contraire de LEA CERAMICHE, suivre avec soin le mode d'emploi signalé par le fabricant sur l'emballage.

Faire toujours un test avant emploi pour vérifier les délais de séchage et d'attente avant circulation piétonne du revêtement de sol traité.

protection joints

nom du produit	fabricant
fugaproof	fila
kf fugenschutz	lithofin

Sauf indication contraire de LEA CERAMICHE, suivre avec soin le mode d'emploi signalé par le fabricant sur l'emballage.

traitements antidérapantes

La résistance au glissement des carrelages posés (aussi bien des carreaux émaillés que des carreaux non émaillés) peut être améliorée avec des produits spécifiques (voir tableau).

Avant d'appliquer le produit sur le revêtement de sol, faire toujours des tests sur les carreaux non posés pour déterminer les temps de pose plus indiqués. Si d'un côté, les longs temps de pose augmentent le coefficient de frottement, de l'autre, ils ont tendance à décolorer un peu les carreaux et à les salir plus vite.

type d'opération	nom du produit	fabricant
traitement antidérapante	safe floor	faberchimica
	safe floor/30	faberchimica
	bonagrip	bonasystems italia

attention:

1. Ne pas faire ces traitements sur les surfaces Rodées ou Polies ;
2. Avant le traitement, contacter le Service Clients Lea ;
3. Il est recommandé de confier le traitement à des entreprises spécialisées.

Les produits **POLIS** peuvent atteindre un niveau d'adhérence **R9** (essai DIN 51130) par le biais de traitements laser ; ceux-ci ne peuvent être effectués que sur les produits **non posés**. Pour les carreaux Polis, le client est donc tenu de spécifier le niveau R9 au service commercial lors de la commande.

Ces traitements laser peuvent aussi être effectués sur les surfaces **RODÉES** (après vérification auprès du Service Clients LEA CERAMICHE).

Quelques noms utiles pag. 424

Informationen zur Reinigung und Pflege

Vor der Reinigung einer gefliesten Fläche wird folgendes empfohlen:

1. Im Hauptkatalog **die Chemikalienbeständigkeit** der verlegten Fliesen prüfen;
2. Einen Vortest direkt auf den verlegten Fliesen vornehmen, indem das zu verwendende Reinigungsmittel über den gleichen Zeitraum wie in der Baustelle mit den Fliesen in Kontakt gebracht wird;
3. Sicherstellen, dass die zu verwendenden Reinigungsmittel **keine** Fluorwasserstoffsäure und/oder ihre Derivate enthalten, da diese Substanzen durch ihre Besonderheit **alle** keramischen Produkte angreifen.

Es folgen einige Angaben zur täglichen, außergewöhnlichen Reinigung am Ende der Bauarbeiten („nach dem Verlegen“), um Wachs und glänzende Schichten zu entfernen und um eventuelle besondere Wartung auszuführen.

Reinigung „nach dem verlegen“

1. Die Reinigung „nach dem Verlegen“ dient zur Entfernung der Spachtelrückstände, Zementrückstände und Kalkrückstände. Sie ist am Ende der Bauarbeiten für die glasierten und unglasierten Fliesen **obligatorisch**.
2. Eine schlecht ausgeführte oder eventuell gar nicht ausgeführte Reinigung „nach dem Verlegen“ ist oft die Ursache von Schatten, die trotz einer täglichen Reinigung die Ursache eines nicht sauberen Bodens sind.
3. Wenn möglich – vor allem bei mittel-großen Oberflächen – empfehlen wir die Anwendung eines Einbürstengeräts mit passenden Scheiben weich (weiß oder beige).

4. reinigung von mit wasser gemischten mörtel

Diese wird mit speziellen Reinigungsmitteln mit gepufferten und verdünnten Säuren ausgeführt. Einige dieser, die im Handel leicht erhältlich sind, sind in der folgenden Tabelle aufgeführt.

Zu entfernender Rest	Reinigungsmittel	Name Reinigungsmittel	Hersteller
Mörtel Zementschlamm Zement Kalk	Mit gepufferten Säuren	keranet	mapei
		cement remover	faberchimica
		deterdek	fila
		trek	kiter
		zementschleierentferner	lothofin
		hmk r63	hmk
		solvacid	geal
		bonaclean	bonasystems italia
		bonadecon(*)	bonasystems italia

Außer bei anders lautenden Angaben von LEA CERAMICHE, werden die Gebrauchsanweisungen der Produkthersteller befolgt.
(*) Für nicht säurebeständige Produkte geeignet

Anleitungen für die Reinigung „nach dem Verlegen“:

1. Die Reinigung 4-5 Tage nach der Verlegung (die Fugenmasse muss aushärten) und nicht nach 10 Tagen ausführen. Über diesen Zeitraum hinaus kann die Reinigung sehr schwierig werden.
2. Den Boden vor der Reinigung mit Wasser benetzen. Auf diese Weise werden die Verfugungen mit Wasser benetzt und der Kontakt mit den Reinigungsmitteln reduziert.
3. Die Reinigungsmittel über eine begrenzte Zeit einwirken lassen und sobald wie möglich mit Wasser spülen.
4. Die Reinigung darf nicht ausgeführt werden, wenn die gefliesten Flächen sehr heiß sind (z.B. im Sommer der Sonne ausgesetzt), da die Wirkung der chemischen Substanzen aggressiver ist. Im Sommer wird sie in den kühlen Stunden des Tags ausgeführt.
5. Vor der Anwendung immer Tests vornehmen (auf einer nicht verlegten Fliese), insbesondere bei geläpten oder polierten Produkten.

5. reinigung von epoxi-, bi-komponent und aktiven spachtelmassen

In diesen Fällen müssen die Stuckrückstände sofort und sehr sorgfältig unter Beachtung der Angaben des Herstellers erfolgen, weil diese Stücke u.U. sehr schnell in wenigen Minuten härten. Die angegebene Reinigungshinweis vom Hersteller der verwendete Fugenmasse sorgfältig befolgen. Vor dem Verfugen des gesamten Belag (Boden u/o Wand), die Wirkung der Reinigungsempfehlung (auch im Gegenlicht!) mit einem Vor-Test Reinigung überprüfen.

6. Rutschfeste fliesen

Aufgrund ihrer Beschaffenheit sind die rutschfesten, rauen oder strukturierten Oberflächen etwas schwieriger zu reinigen. Aus diesem Grunde ist die Reinigung sehr wichtig. Für eine schnellere Reinigung wird der Einsatz einer Scheibenmaschine mit einer weissen oder beige Scheibe empfohlen.

Sonderreinigung

Sie wird ausgeführt, um besonders alte oder hartnäckige Flecken oder Reste zu entfernen. Vor der Anwendung immer Tests vornehmen (auf einer nicht verlegten Fliese), insbesondere bei **geläpften** und **polierten** Fliesen.

In der unten aufgeführten Tabelle sind wirksame Reinigungsmittel je nach Fleckenart angegeben.

Zu entfernender Rest	Art des Reinigungsmittels	Name Reinigungsmittel	Hersteller
Fette Trittstaub Grundreinigung	Polyfunktionell, mit Alkalibasis (1)	ps87	fila
		intensivreiniger	lithofin
		hmk r55	hmk
		taski r20-strip	johnsondiversey
		bonamain	bonasystems italia
		bonadecon	bonasystems italia
Kaffee Coca Cola Obstsäfte	Polyfunktionell, mit Alkalibasis (1)	coloured stain remover	faberchimica
		ps87	fila
Wein	Oxydierend	oxidant	faberchimica
Kalkrückstände	Mit Säurebasis (1)	viakal verdünnte salzsäure	procter & gamble verschiedene hersteller
Rost	Mit Säurebasis (1)	verdünnte salzsäure	verschiedene hersteller
Tinten Filzstift	Mit Lösungsmittel	Nitroverdünner, Dichloräthylen, Terpentin	Verschiedene Hersteller
		coloured stain remover	faberchimica
Reifen Gummiflecken Metall Bleistift	scheuermittel	vim clorex (2)	guaber
		polishing cream (2)	faberchimica
		strong remover (3)	faberchimica
		detergum (3)	zep italia
Fugenschmutz	Spezifisch	fuganet	fila
		fugenreiniger	lithofin

(1) Vortesten auf geläpften und polierten Materialien

(2) Für geläppte und polierte Materialien

(3) Nicht auf geläpften Produkten verwenden, sehr vorsichtig auf polierten Materialien verwenden.

Außer bei anders lautenden Angaben von LEA CERAMICHE, die von den Herstellern angegebenen Gebrauchsanweisungen befolgen.

Informationen zur Reinigung und Pflege

Tägliche / regelmäßige reinigung

Neutrale, in lauwarmem Wasser verdünnte Reinigungsmittel benützen, die keine **Wachselemente enthalten** und **keine Glanzpatina absetzen**. Mit einem Tuch aus **Mikrofaser** abwaschen. Nach dem Abwaschen, mit reinem Wasser gut spülen und die Abwaschungsreste mit einem zweiten **Mikrofaser**-Tuch entfernen. Es werden folgende Produkte empfohlen, die im Handel erhältlich sind.

Vorgangsart	Art des Reinigungsmittels	Name Reinigungsmittel	Hersteller
Tägliche Reinigung	Neutral	floor cleaner	faberchimica
		fila cleaner	fila
		pflgereiniger	lithofin
		hmk p15	hmk
		bonamain plus	bonasystems italia

Außer bei anders lautender Angabe durch LEA CERAMICHE, die Gebrauchsanleitungen der Hersteller befolgen.

Reinigung des fliesendekors

- Verwenden Sie ausschließlich NEUTRALE und verdünnte Reinigungsmittel oder Alkohol.
- VERWENDEN SIE AUF KEINEN FALL**
- Ätzende oder alkalische Reinigungsmittel
- Scheuerpasten- und Pulver (Detergum, StrngRemover, Polishing Cream, Vim Clorex, usw.)
- Grobe Bürsten oder abrasive Schwämme.

Entfernen von glänzenden schichten

In den normalen handelsüblichen Reinigungsmitteln sind manchmal Wachse oder glänzende Zusätze enthalten, die nach jeder Reinigung **glänzende** Schichten auf dem Boden hinterlassen, die hartnäckige Streifen verursachen. Schichten dieser Art können auch von einiger Fugenmassen hinterlassen werden. Einfache Lebensmittel wie Coca Cola, Wein, Wasser usw. entfernen durch Fallen auf den Boden diese glänzende Schicht und bringen den matten **Originalzustand** der Fliesen wieder zum Erscheinen. Auf dem glänzenden Teil des Bodens erscheinen die Bereiche ohne Wachs als matte Schatten, eigentlich handelt es sich um die einzigen sauberen Bereiche des Bodens.

In diesen Fällen muss man:

1. Zuerst die glänzende Schicht vom ganzen Boden entfernen (siehe folgende Tabelle);
2. Dann zur täglichen Reinigung neutrale Reinigungsmittel verwenden, die keine Wachse oder glänzende Zusätze enthalten (siehe vorheriger Abschnitt „tägliche/regelmäßige Reinigung“).

Zu entfernter Rest	Art des Reinigungsmittels	Name Reinigungsmittel	Hersteller
Glänzende Schichten	Leicht sauer	tile cleaner pur (*)	faberchimica
		bonadecon pur (*)	bonasystems italia

(*) Die Angaben auf der Verpackung nicht befolgen, sondern das Reinigungsmittel pur anwenden, 5-10 Minuten einwirken lassen, mit weichen Kissen abreiben (weiß, gelb) und gut mit Wasser abspülen.

Keine Wachse auf Feinsteinzeug von LEA CERAMICHE verwenden.

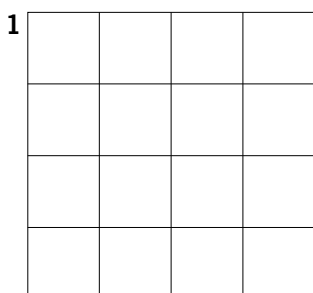

Originalfußboden.

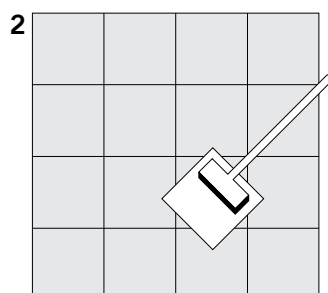

Nach der Reinigung mit wachshaltigen Reinigungsmitteln.

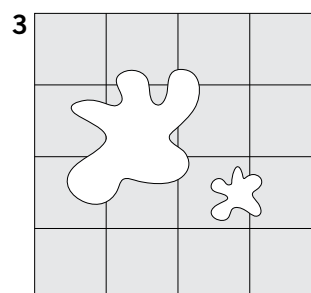

Normale Lebensmittel (Coca-Cola, Wein, Wasser usw..) können die glänzende Patina entfernen. Die Originaloberfläche ist matter.

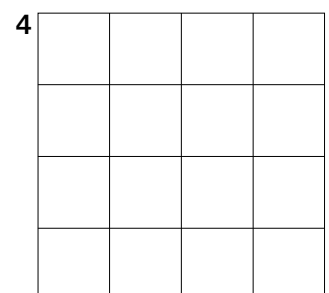

Die Patina sollte mit Reinigungsmittel entfernt werden (Tile cleaner pur von Faber) und für die tägliche Reinigung sollte ein wachsfreies Reinigungsmittel verwendet werden.

Besondere wartung

schutzmittel für poliertes feinsteinzeug

Zur Reinigung des Feinsteinzeugs von LEA CERAMICHE können die folgenden Produkte verwendet werden.

produktname	hersteller
mp 90	fila
gres lux 90	faber chimica
keraseal	federchemicals

Außer bei anders lautender Angabe von LEA CERAMICHE die Gebrauchsanleitungen der Hersteller befolgen.

Immer einen Vortest ausführen, um die Trockenzeiten und die Begehbarkeit des behandelten Bodens zu prüfen.

fugenschutzmittel

produktname	hersteller
fugaproof	fila
kf fugenschutz	lithofin

Außer bei anders lautender Angabe der LEA CERAMICHE die Gebrauchsanleitungen der Hersteller befolgen.

rutschfeste behandlung

Die Rutschfestigkeit der verlegten Böden (glasierte sowie unglasierte Fliesen) kann durch Anwendung spezifischer Produkte erhöht werden (siehe Tabelle).

Bevor das Produkt auf dem Boden aufgetragen wird, werden Vortests auf nicht verlegten Fliesen vorgenommen, um die geeignete Kontaktzeit zu finden. Wenn längere Zeiten auf der einen Seite die Rutschfestigkeit erhöhen, neigen sie auf der anderen Seite dazu, die Farben der Fliesen zu bleichen und sie etwas schmutzempfindlicher zu machen.

vorgang	produktname	hersteller
rutschfestigkeits-Behandlung	safe floor	faberchimica
	safe floor/30	faberchimica
	bonagrip	bonasystems italia

Achtung:

1. Diese Behandlungen nicht auf geläppten oder polierten Oberflächen verwenden;
2. Vor der Behandlung den Kundenservice Lea fragen;
3. Wir empfehlen, die Behandlung durch spezialisierte Firmen auszuführen.

Die **POLIERTEN** Produkte können den Grad **R9** (Test DIN51130) mit geeigneten Laserbehandlungen erreichen, die nur bei **nicht verlegtem** Material ausgeführt werden können: Somit muss die Anforderung des Grads R9 für polierte Produkte im Auftrag an die Verkaufsabteilung angegeben werden. Diese Laserbehandlungen können auch auf **GELÄPPTEN** Oberflächen ausgeführt werden (nach der Prüfung des Kundenservice von LEA CERAMICHE).

Nützliche adressen pag. 424

Información para la limpieza y manutención

Antes de limpiar una superficie alicatada es recomendable:

1. Comprobar en el catálogo general la resistencia a los agentes químicos de las baldosas colocadas;
2. Realizar una prueba preliminar directamente sobre las baldosas, echando el detergente que se va a utilizar sobre las baldosas durante un tiempo igual al que se usará después en la obra.
3. Asegurarse que los detergentes que se van a usar no contengan ácido fluorhídrico y/o derivados, ya que dichas sustancias agraden todos los productos cerámicos debido a sus peculiares características.

A continuación se detallan algunas indicaciones para las limpiezas de final de obra (después de la colocación) diarias y extraordinarias para la retirada de cera y pátinas abrillantadoras, así como manutenciones especiales.

Limpieza “después de la colocación”

1. La limpieza “después de la colocación” sirve para quitar los residuos de estuco de escapes, cemento, cal o mortero. Es obligatoria al final de la obra de construcción, tanto para las baldosas esmaltadas como para las que no lo son.
2. Una limpieza “después de la colocación” mal realizada, o incluso no realizada, a menudo constituye la causa de cercos que impiden mantener limpio el pavimento, aun con una buena limpieza diaria.
3. Cuando sea posible, sobre todo para superficies medio-grandes, se recomienda utilizar una máquina mono disco con cerdas suaves (blancas o beige).

4. Limpieza de estuco cementicio mezclado con agua

Se realiza con detergentes específicos a base de ácidos tamponados y libres. Algunos de ellos, disponibles a la venta, se muestran en la siguiente tabla.

residuo por retirar	tipo de detergente	nombre detergentes	fabricante
estuco cementicio mortero cemento cal	a base de ácidos tamponados	keranet	mapei
		cement remover	faberchimica
		deterdek	fila
		trek	kiter
		zementschleierentferner	lothofin
		hmk r63	hmk
		solvacid	geal
		bonaclean	bonasystems italia
		bonadecon(*)	bonasystems italia

Excepto indicación contraria de LEA CERAMICHE, siga atentamente el modo de uso indicado en los envases por los fabricantes.
(*) Especificado para productos no resistentes a los ácidos

Indicaciones para la limpieza “después de la colocación”:

1. Realice la limpieza después de 4-5 días desde el estucado (el estuco debe endurecerse) y no más de 10 días. Después de este periodo de tiempo, la limpieza puede resultar más complicada.
2. Moje con agua el suelo antes de los trabajos de limpieza. De este modo, el estucado se impregnará con el agua y se reducirá el contacto con los detergentes.
3. Deje actuar los detergentes durante un tiempo limitado, aclarando bien con agua en cuanto sea posible.
4. No debe limpiar si la superficie alicatada está muy caliente (p.ej.: expuesta al sol en los meses más calurosos), ya que la acción de los agresivos químicos será más grave. En verano, realice la limpieza en las horas más frescas del día.
5. Efectúe siempre pruebas preventivas antes del uso (sobre una baldosa no colocada), sobre todo para los productos Lappati o Levigati.

5. Limpieza de estucos epoxídicos a dos componentes

Los residuos de estos estucos deben quitarse inmediatamente y con cuidado ya que estos estucos endurecen rápidamente, incluso en pocos minutos. Seguir atentamente las instrucciones de limpieza aconsejadas por el fabricante del estuco a utilizar, y verificar la eficacia (también al contraluz) realizando una prueba de limpieza antes de proceder a la completa lechada del suelos/paredes.

6. baldosas antideslizantes

las baldosas antideslizantes, fabricadas con superficies ásperas y/o estructuradas, se limpian de forma más complicada. Se recomienda por tanto limpiar “después de la colocación” de forma rápida y precisa, utilizando la máquina mono disco con cerdas blancas o beige.

Limpieza extraordinaria

Se lleva a cabo para retirar manchas o residuos especialmente viejos o resistentes. Antes del uso, efectúe siempre pruebas preventivas (sobre una baldosa no colocada), sobre todo en **Lappati** y **Levigati**.

En la tabla se indican los detergentes más eficaces según el tipo de mancha.

residuo por retirar	tipo de detergente	nombre detergentes	fabricante
grasas polvo de pisadas limpieza a fondo	polifuncionales a base de alcalina (1)	ps87	fila
		intensivreiniger	lithofin
		hmk r55	hmk
		taski r20-strip	johnsondiversey
		bonamain	bonasystems italia
		bonadecon	bonasystems italia
café coca-cola zumos de fruta	polifuncionales a base de alcalina (1)	coloured stain remover	faberchimica
		ps87	fila
vino	oxidante	oxidant	faberchimica
depósitos calcáreos	con base ácida (1)	viakal	procter & gamble
herrumbre	con base ácida (1)	ácido muriático diluido	varie a productores
tinta rotulador	con base solvente	diluyente nitro, perfil de troquel, trementina	varios productores
		coloured stain remover	faberchimica
neumáticos marcas de goma de metales de lápiz	goma abrasiva	vim clorex (2)	guaber
		polishing cream (2)	faberchimica
		strong remover (3)	faberchimica
		detergum (3)	zep italia
suciedad de escapes	específico	fuganet	fila
		fugenreiniger	lithofin

(1) Efectúe pruebas preventivas sobre materiales Lappati y Levigati

(2) Indicado para materiales Lappati y Levigati

(3) No utilice sobre productos Lappati, preste mucha atención cuando lo use sobre productos Levigati

Excepto indicación contraria de LEA CERAMICHE, siga atentamente el modo de uso indicado en los envases por los fabricantes.

Información para la limpieza y manutención

Limpieza diaria / ordinaria

Utilizar detergentes neutros, diluidos en agua caliente, que no contengan ceras o que no depositen pátinas brillantes, quitando las aguas del lavado con un paño de microfibra. Aclarar bien con agua al acabar el lavado, quitando las aguas del lavado con un segundo paño de microfibra. Se aconsejan los siguientes productos vendidos en comercios.

tipo de operación	limpieza diaria	tipo de detergente	fabricante
limpieza diaria	neutro	floor cleaner	faberchimica
		fila cleaner	fila
		pflgereiniger	lithofin
		hmk p15	hmk
		bonamain plus	bonasystems italia

Excepto indicación contraria de LEA CERAMICHE, siga atentamente el modo de uso indicado en los envases por los fabricantes.

Limpieza de decorados

- Utilizar detergentes NEUTROS y diluidos, alcohol.
- NO UTILIZAR NUNCA**
- Detergentes ácidos o alcalinos
- Pastas abrasivas (Detergum, StrngRemover, Polishing Cream, Vim Clorex, etc.)
- Cepillos o esponjas abrasivas.

Eliminación de pátinas brillantes

Los detergentes normales a la venta contienen en ocasiones ceras o aditivos abrillantadores que, lavado tras lavado, dejan sobre el pavimento pátinas brillantes que constituyen la causa de cercos molestos. Este tipo de pátinas pueden encontrarse debido al uso de algunos estucos para escapes. Alimentos tan simples como Coca Cola, vino, agua, etc., que sobre el suelo quitan esta pátina brillante y reestablecen el aspecto original opaco de las baldosas. En el suelo más brillante, las zonas sin cera aparecen como cercos opacos, aunque en realidad son las únicas partes limpias de todo el pavimento. Para estos casos es necesario:

1. Ante todo, quitar la pátina brillante de todo el suelo (véase tabla siguiente);
2. A continuación, para limpiezas diarias, utilizar detergentes neutros que no contengan ceras o pátinas brillantes (véase párrafo anterior "limpieza diaria / ordinaria").

residuo por retirar	tipo de limpieza diaria	tipo de detergente	fabricante
pátina brillante	ligeramente ácido	tile cleaner puro (*) bonadecon puro (*)	faberchimica bonasystems italia

(*) No siga las indicaciones del envase, y aplique el detergente puro. Deje actuar durante 5-10 minutos, frote con absorbentes suaves (blanco, amarillo) y aclare bien con agua.

No utilice ceras sobre el gres porcelánico LEA CERAMICHE.

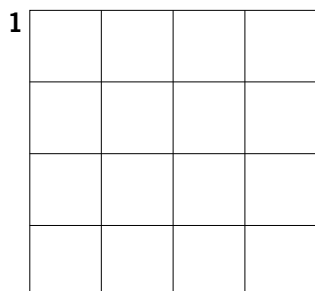

Pavimento original.

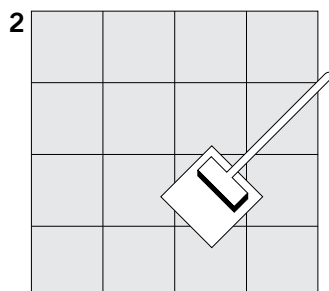

Después de la limpieza con detergentes con ceras.

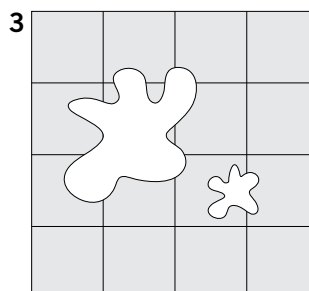

Alimentos simples (Coca-Cola, vino, agua, etc.) pueden quitar la pátina brillante. La superficie original es más opaca.

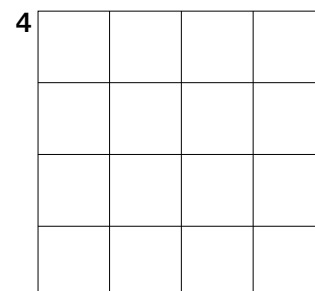

Quite la pátina con detergente (Tile Cleaner puro, Faber) y use diariamente un detergente sin cera.

Manutención extraordinaria

protectores para gres pulido

Para facilitar la limpieza del Gres Levigato LEA CERAMICHE se pueden aplicar los siguientes productos.

nombre producto	fabricante
mp 90	fila
gres lux 90	faber chimica
keraseal	federchemicals

Excepto indicación contraria de LEA CERAMICHE, siga atentamente el modo de uso indicado en los envases por los fabricantes. Efectúe siempre una prueba preventiva para comprobar los tiempos de secado y pisado del suelo.

protectores para escapes

nombre producto	fabricante
fugaproof	fila
kf fugenschutz	lithofin

Excepto indicación contraria de LEA CERAMICHE, siga atentamente el modo de uso indicado en los envases por los fabricantes.

tratamientos antideslizantes

La resistencia antideslizante de los suelos colocados (baldosas esmaltadas o no esmaltadas) puede aumentarse usando productos específicos (véase tabla).

Antes de aplicar el producto sobre el pavimento, realice pruebas preventivas sobre las baldosas no colocadas para averiguar los tiempos de contacto más idóneos. Si por una parte, los tiempos más largos aumentan el grado de adherencia, por otra, tienden un poco a emblanquecer los colores de las baldosas y a volverlos algo más propensas a ensuciarse.

tipo de operación	nombre producto	fabricante
tratamiento antideslizante	safe floor	faberchimica
	safe floor/30	faberchimica
	bonagrip	bonasystems italia

atención:

1. No use estos tratamientos sobre superficies Lappate o Levigate;
2. Antes del tratamiento, póngase en contacto con el Servicio de Atención al Cliente de Lea;
3. Se recomienda realizar el tratamiento a través de empresas especializadas.

Los productos **LEVIGATI** pueden alcanzar el grado **R9** (prueba DIN51130) con los tratamientos adecuados con láser realizables solo sobre materiales no colocados: por ello, la solicitud de R9 para Levigati debe especificarse en el momento de la orden de compra al departamento comercial. Estos tratamientos con láser pueden llevarse a cabo sobre superficies **LAPPATE** (después de comprobarlo con el Servicio de Atención al Cliente de LEA CERAMICHE).

Referencias útiles pag. 424

Riferimenti utili / Useful contacts / Quelques noms utiles / Nützliche adressen / Referencias útiles:

MAPEI SpA, via Cafiero 22, 20158 Milano – ITALY

Tel. +39 02 37673 – www.mapei.it

FABERCHIMICA Srl, via G. Ceresani 10 – località Campo d'Olmo 60044 Fabriano (AN) – ITALY Tel. +39 0732 627178 – www.faberchimica.com

FILA Industria Chimica SpA, via Garibaldi 32, 35018 S. Martino dei Lupari (PD) - ITALY

Tel. +39 049 9467300 – www.filachim.it

ZEP Italia Srl, via Nettunese Km 25,000 – 04011 Aprilia (LT) – ITALY

Tel. +39 06 926691 – www.zepitalia.it

JOHNSONDIVERSEY, via Meucci, 40 – 20128 Milano

Tel. +39 0373 2051 – www.johnsondiverse.com

KITER Srl, via Assiano 7/B – 20019 Settimo Milanese (MI) – ITALY

Tel. +39 02 3285220 – www.kiter.it

GEAL Srl, via Settola 121 - 51031 Agliana (Pistoia) - ITALY

Tel. +39 0574 750365 - www.geal-chim.it

FEDERCHEMICALS Srl, via Borsi 2 - 25100 Brescia - ITALY

Tel. +39 030 3385578 - www.federchemicals.it

LITHOFIN-Produkte GmbH, Postfach 1134, D-73236 Wendlingen (D)

Service – Tel. 0049 07024/940320 – www.lithofin.de

Vertrieb für Österreich: CT-Austria Ges.m.b.H. A-1230 Wien Tel. 0043 01 8673434

HMK - MÖLLER-CHEMIE Benelux GmbH – Linge 4 NL-2105 WB Heemstede (NL)

Tel. 0031 0252-220222 – www.moellerchemie.de

BONASYSTEMS ITALIA Srl, via Borgo Santa Chiara 29 - 30020 Torre di Mosto (Venezia) - ITALY

Tel. +39 0421 325691 - www.bonasytemsitalia.it - info@bonasytemsitalia.it

Imballi

packing / emballage

verpackung / embalajes

ANCIENT JERUSALEM

articolo			scatola			europallet		
	cm	inch	pz.	mq	kg	scat.	mq	kg
fondo	48,5x48,5	19"x19"	6	1,41	31,6	24	33,9	758,4
fondo	32,2x48,5	12 ^{5/8} "x19"	7	1,10	23,1	44	48,1	1016,4
fondo	32,2x32,2	12 ^{5/8} "x12 ^{5/8} "	12	1,25	28,0	42	52,3	1176,0
fondo	15,9x32,2	6 ^{1/4} "x12 ^{5/8} "	24	1,23	28,0	48	59,0	1344,0
fondo	15,9x15,9	6 ^{1/4} "x6 ^{1/4} "	48	1,21	27,0	48	58,3	1296,0
mosaico 6	32,2x32,2	12 ^{5/8} "x12 ^{5/8} "	5	0,52	10,0	60	31,1	600,0
battiscopa	8x32,2	3 ^{1/8} "x12 ^{5/8} "	44	14,2 m.l.	23,0	20	283,4 m.l.	460,0
gradino	32,2x32,2	12 ^{5/8} "x12 ^{5/8} "	12	1,24	28,0	42	52,3	1174,3
torello gradino bordo	5,5x32,2	2 ^{1/8} "x12 ^{5/8} "	6	-	3,0	-	-	-
torello gradino angolo	5,5x32,2	2 ^{1/8} "x12 ^{5/8} "	2	-	2,0	-	-	-
quarter round	2,8x6	1 ^{1/8} "x2 ^{3/8} "	32	-	-	-	-	-
beak	2,8x2,8	1 ^{1/8} "x1 ^{1/8} "	20	-	-	-	-	-

ARENARIA

articolo			scatola			europallet		
	cm	inch	pz.	mq	kg	scat.	mq	kg
fondo	60x120	24"x48"	2	1,44	37,0	24	34,6	888,0
fondo	60x60	24"x24"	4	1,44	32,0	32	46,1	1024,0
fondo	60,4x60,4	24"x24"	4	1,46	32,0	32	46,7	1024,0
fondo	30x60	12"x24"	8	1,44	32,0	32	46,1	1024,0
fondo	30x60,4	12"x24"	9	1,63	32,4	32	52,2	1036,8
mosaico 1	28,5x28,5	11 ^{1/4} "x11 ^{1/4} "	5	0,40	7,1	48	19,5	340,8
link	30x60	12"x24"	4	0,72	15,5	40	28,8	620,0
battiscopa	10x60	4"x24"	12	7,2 m.l.	18,0	45	324,0 m.l.	810,0
gradino plus	35x120	13 ^{3/4} "x48"	2	0,84	23,2	24	20,2	556,8
angolo gradino plus	35x120	13 ^{3/4} "x48"	1	0,42	12,4	24	10,1	297,6
beak	1,3x1,3	1/2"x1/2"	4	-	-	-	-	-
raccordo jolly	1,3x30	1/2"x12"	8	-	-	-	-	-

ARENARIA SLIMTECH

articolo			scatola			europallet		
	cm	inch	pz.	mq	kg	scat.	mq	kg
fondo 3mm	100x300	39"x118"	1	3,0	22,2	13 pz/pl	39,0	288,6
fondo 3plus	100x300	39"x118"	1	3,0	25,3	12 pz/pl	36,0	304,2
fondo 3plus	100x100	39"x39"	3	3,0	24,1	25	75,0	602,5
fondo 3mm	50x100	19 ^{1/2} "x39"	5	2,50	17,8	32	80,0	569,6
fondo 3plus	50x100	19 ^{1/2} "x39"	5	2,50	20,0	32	80,0	640,0
fondo 3plus	50x50	19 ^{1/2} "x19 ^{1/2} "	7	1,75	14,0	48	84,0	672,0
fondo 3mm	4,9x100	2"x39"	10	0,49	4,0	39	19,1	156,0
fondo 3plus	4,9x100	2"x39"	10	0,49	4,2	39	19,1	163,8
decoro bamboo	50x100	19 ^{1/2} "x39"	2	1,0	7,1	15	15,0	106,8
mosaico quadro	25x25	10"x10"	10	0,62	4,6	60	37,5	276,0
mosaico mattone	25x25	10"x10"	10	0,62	4,6	60	37,5	276,0
mosaico striscia	25x50	10"x19 ^{1/2} "	10	1,25	6,9	60	75,0	414,0
mosaico listello	25x50	10"x19 ^{1/2} "	10	1,25	6,9	60	75,0	414,0

Imballi

packing / emballage

verpackung / embalajes

ATHENA

articolo			scatola			europallet		
	cm	inch	pz.	mq	kg	scat.	mq	kg
fondo	35x100	13 ^{3/4} "x39"	3	1,05	22,0	26	27,3	570,7
fondo	35x35	13 ^{3/4} "x13 ^{3/4} "	9	1,1	21,2	24	26,4	508,8
mosaico	35x35	13 ^{3/4} "x13 ^{3/4} "	3	0,37	5,7	50	18,4	285,0
decoro aster	35x100	13 ^{3/4} "x39"	3	1,05	21,3	8	8,4	170,4
decoro ithys	35x100	13 ^{3/4} "x39"	3	1,05	21,3	8	8,4	170,4
decoro rhombos	35x100	13 ^{3/4} "x39"	3	1,05	21,3	8	8,4	170,4
decoro greca	10x35	4"x13 ^{3/4} "	6	0,21	4,5	-	-	-
battiscopa	12x35	4 ^{3/4} "x13 ^{3/4} "	6	2,1 m.l.	5,0	-	-	-
angolo battiscopa	2,5x12	1"x4 ^{3/4} "	6	0,02	0,3	-	-	-
chair rail	5,5x35	2 ^{1/8} "x13 ^{3/4} "	6	0,1	2,1	-	-	-
angolo chair rail	5,5x3,5	2 ^{1/8} "x1 ^{3/8} "	9	0,01	0,1	-	-	-
liner	2x35	3/4"x13 ^{3/4} "	12	0,08	1,6	-	-	-
angolo liner	2x2	3/4"x3/4"	9	0,04	0,4	-	-	-
raccordo jolly	1,5x33,3	5/8"x13 ^{1/8} "	12	0,06	0,72	-	-	-
beak	1,5x1,5	5/8"x5/8"	4	-	0,02	-	-	-

AUDREY

articolo			scatola			europallet		
	cm	inch	pz.	mq	kg	scat.	mq	kg
fondo	35x70	13 ^{3/4} "x27 ^{1/2} "	4	0,98	18,1	56	54,9	1313,6
fondo	35x35	13 ^{3/4} "x13 ^{3/4} "	9	1,10	21,3	24	26,4	511,2
decoro blossoms	35x70	13 ^{3/4} "x27 ^{1/2} "	4	0,98	18,1	6	5,9	108,5
decoro dots	35x70	13 ^{3/4} "x27 ^{1/2} "	4	0,98	18,1	6	5,9	108,5
decoro galles	35x70	13 ^{3/4} "x27 ^{1/2} "	4	0,98	18,1	6	5,9	108,5
decoro stripes	35x70	13 ^{3/4} "x27 ^{1/2} "	4	0,98	18,1	6	5,9	108,5
mentine	30x32	12"x24"	6	0,58	15,6	-	-	-
chair rail	7x35	2 ^{3/4} "x13 ^{3/4} "	10	0,25	6,0	-	-	-
ang. chair rail	2x7	3/4"x2 ^{3/4} "	4	-	0,1	-	-	-
liner	2x35	3/4"x13 ^{3/4} "	12	-	1,2	-	-	-
ang. liner	2x2	3/4"x3/4"	4	-	0,01	-	-	-
raccordo jolly	2x35	3/4"x13 ^{3/4} "	12	0,08	1,2	-	-	-
beak	2x2	3/4"x3/4"	4	-	0,1	-	-	-

BASALTINA STONE PROJECT

articolo			scatola			europallet		
	cm	inch	pz.	mq	kg	scat.	mq	kg
fondo	60x120	24"x48"	2	1,44	40,8	24	34,6	979,2
fondo	75x75	30"x30"	2	1,13	27,4	40	45,0	1096,0
fondo	60x60	24"x24"	4	1,44	35,0	24	34,6	840,0
fondo	30x60	12"x24"	8	1,44	34,9	32	46,1	1116,8
mosaico 1	28,5x28,5	11 ^{1/4} "x11 ^{1/4} "	5	0,41	7,8	48	19,5	372,0
muretto	30x60	12"x24"	4	0,72	15,2	30	21,6	456,0
battiscopa	10x60	4"x24"	12	7,2 m.l.	18,0	55	396,0 m.l.	990,0
gradino plus	35x120	13 ^{3/4} "x48"	2	0,84	25,2	24	20,2	604,8
angolo gradino plus	35x120	13 ^{3/4} "x48"	1	0,42	13,5	24	10,1	324,0
gradino plus	35x60	13 ^{3/4} "x24"	4	0,84	23,2	24	20,2	556,8
angolo gradino plus	35x35	13 ^{3/4} "x13 ^{3/4} "	4	0,49	14,8	30	14,7	444,0
raccordo jolly	1,3x30	1/2"x12"	8	0,03	0,3	-	-	-
beak	1,3x1,3	1/2"x1/2"	4	-	-	-	-	-

BASALTINA STONE PROJECT SLIMTECH

articolo			scatola			europallet		
	cm	inch	pz.	mq	kg	scat.	mq	kg
fondo 3mm	100x300	39"x118"	1	3,0	22,2	13 pz/pl	39,0	288,6
fondo 3plus	100x300	39"x118"	1	3,0	25,3	12 pz/pl	36,0	304,2
fondo 3plus	100x100	39"x39"	3	3,0	24,1	25	75,0	602,5
fondo 3mm	50x100	19 1/2"x39"	5	2,50	17,8	32	80,0	569,6
fondo 3plus	50x100	19 1/2"x39"	5	2,50	20,0	32	80,0	640,0
fondo 3plus	50x50	19 1/2"x19 1/2"	7	1,75	14,0	48	84,0	672,0
fondo 3mm	4,9x100	2"x39"	10	0,49	4,0	39	19,1	156,0
fondo 3plus	4,9x100	2"x39"	10	0,49	4,2	39	19,1	163,8
mosaico quadro	25x25	10"x10"	10	0,62	4,6	60	37,5	276,0
mosaico mattone	25x25	10"x10"	10	0,62	4,6	60	37,5	276,0
mosaico striscia	25x50	10"x19 1/2"	10	1,25	6,9	60	75,0	414,0
mosaico listello	25x50	10"x19 1/2"	10	1,25	6,9	60	75,0	414,0
mosaico metal	50x100	19 1/2"x39"	2	1,0	9,9	25	25,0	247,6
mosaico glitter	50x100	19 1/2"x39"	2	1,0	8,8	25	25,0	220,7
mosaico inox	25x25	10"x10"	10	0,62	4,6	60	37,5	276,0
mosaico satin	25x25	10"x10"	10	0,62	4,6	60	37,5	276,0
mosaico pearl	25x25	10"x10"	10	0,62	4,6	60	37,5	276,0

BIOESSENZE

articolo			scatola			europallet		
	cm	inch	pz.	mq	kg	scat.	mq	kg
fondo	15x120	6"x48"	6	1,08	28,7	32	34,6	918,4
fondo	20x120	8"x48"	4	0,96	26,3	36	34,6	946,4
fondo	9x90	3 1/2"x36"	13	1,05	23,4	48	50,5	1123,2
decoro intreccio	30x30	12"x12"	6	0,54	10,2	60	32,4	612,0
composizione listello	30x60	12"x24"	4	0,72	16,6	36	25,9	596,2
decoro cassettone	60x60	24"x24"	2	0,72	18,4	18	13,0	331,2
battiscopa	7,5x60	3"x24"	12	7,2 m.l.	14,5	56	403,2 m.l.	812,0
battiscopa	10x60	4"x24"	12	7,2 m.l.	19,7	56	403,2 m.l.	1103,2
battiscopa	9x45	3 1/2"x18"	20	9,0 m.l.	18,0	35	315,0 m.l.	630,0
gradino	20x120	8"x48"	4	0,96	26,3	36	34,6	946,1
gradino	15x120	6"x48"	6	1,08	28,7	32	34,6	917,8
gradino	9x90	3 1/2"x36"	13	1,05	23,4	48	50,5	1123,2
toro grad. bordo su rete	4x60	1 9/16"x24"	6	0,14	6,0	-	-	-
toro grad. ang. bordo su rete	4x60	1 9/16"x24"	2	0,10	2,0	-	-	-

BIO PLANK

articolo			scatola			europallet		
	cm	inch	pz.	mq	kg	scat.	mq	kg
fondo	20x120	8"x48"	4	0,96	24,5	36	34,6	882,0
fondo	15x120	6"x48"	6	1,08	26,5	32	34,6	848,0
fondo	12x120	4 3/4"x36"	6	0,87	22,5	40	34,6	900,0
decoro fence	20x120	8"x48"	4	0,96	24,5	12	11,5	294,0
decoro axe	30x60	12"x24"	4	0,72	16,0	40	28,8	640,0
battiscopa	10x60	4"x24"	12	7,2 m.l.	18,0	55	396,0 m.l.	990,0
gradino plus	35x120	13 3/4"x48"	2	0,84	23,2	24	20,2	556,8
angolo gradino plus	35x120	13 3/4"x48"	1	0,42	12,4	24	10,1	297,6

Imballi

packing / emballage

verpackung / embalajes

BIO TIMBER

articolo			scatola			europallet		
			pz.	mq	kg	scat.	mq	kg
fondo	20x120	8"x48"	4	0,96	24,5	36	34,6	882,0
fondo	15x120	6"x48"	6	1,08	26,5	32	34,6	848,0
compass	20x120	8"x48"	2	0,48	12,3	54	25,9	661,5
strip	20x120	8"x48"	2	0,48	12,3	54	25,9	661,5
triangles	20x120	8"x48"	2	0,48	12,3	54	25,9	661,5
mosaico wall	31x31	12 1/4"x12 1/4"	4	0,38	9,8	60	23,1	588,0
battiscopa	10x60	4"x24"	12	7,2 m.l.	18,0	56	403,0 m.l.	1008,0
gradino plus	35x120	13 3/4"x48"	2	0,84	23,2	24	20,2	556,8
angolo gradino	35x120	13 3/4"x48"	1	0,42	12,4	24	10,1	297,6
raccordo jolly	1,3x30	1/2"x12"	16	-	1,3	-	-	-
beak jolly	1,3x2	1/2"x3/4"	4	-	0,1	-	-	-

BLUE MOUNTAIN

articolo			scatola			europallet		
			pz.	mq	kg	scat.	mq	kg
	cm	inch						
fondo spess 11	90x90	36"x36"	2	1,62	40,0	24	38,9	960,0
fondo spess 11	45x90	18"x36"	3	1,22	30,0	27	32,8	810,0
fondo spess 11	30x90	12"x36"	3	0,81	20,0	27	21,9	540,0
fondo spess 11	22,5x90	9"x36"	4	0,81	20,0	46	37,3	920,0
fondo spess 11	15x90	6"x36"	6	0,81	20,0	45	36,5	900,0
fondo spess 11	10x90	4"x36"	9	0,81	20,0	40	32,4	800,0
fondo spess 11	75x75	30"x30"	2	1,13	27,4	40	45,0	1096,0
fondo spess 11	37,5x75	15"x30"	5	1,41	34,3	32	45,0	1096,0
fondo spess 10	60x60	24"x24"	4	1,44	32,0	32	46,1	1024,0
fondo spess 10	60,4x60,4	24"x24"	4	1,46	32,0	32	46,7	1024,0
fondo spess 10	30x60	12"x24"	8	1,44	32,0	32	46,1	1024,0
fondo spess 10	30x60,4	12"x24"	8	1,45	32,0	32	46,4	1024,0
muretto	30x60	12"x24"	4	0,72	14,5	30	21,6	435,0
mosaico	30x30	12"x12"	5	0,45	10,0	60	27,0	600,0
mosaico mattone	30x30	12"x12"	5	0,45	10,0	60	27,0	600,0
battiscopa	10x60	4"x24"	12	7,2 m.l.	18,0	50	360,0 m.l.	900,0
gradino step	60x60	24"x24"	4	1,44	36,0	24	34,6	864,0

CITY

articolo			scatola			europallet		
			pz.	mq	kg	scat.	mq	kg
	cm	inch						
fondo	30x60	12"x24"	4	0,72	15,6	24	17,3	374,4

DREAMING

articolo			scatola			europallet		
			pz.	mq	kg	scat.	mq	kg
	cm	inch						
fondo	75x75	30"x30"	2	1,13	28,5	40	45,0	1140,0
fondo	60x60	24"x24"	4	1,44	32,0	32	46,1	1024,0
fondo	30x60	12"x24"	8	1,44	32,0	32	46,1	1024,0
mosaico	30x30	12"x12"	4	0,36	8,4	60	21,6	501,0
battiscopa	10x60	4"x24"	12	7,2 m.l.	16,7	60	432 m.l.	1002,0
gradino plus	35x60	13 3/4"x24"	4	0,84	21,4	24	20,2	513,6
angolo gradino plus	35x35	13 3/4"x13 3/4"	4	0,49	13,4	30	14,7	402,0
raccordo jolly	1,3x30	1/2"x12"	16	-	1,3	-	-	-
beak jolly	1,3x2	1/2"x3/4"	4	-	0,1	-	-	-

GOCCIA

articolo			scatola			europallet		
	cm	inch	pz.	mq	kg	scat.	mq	kg
tune	13x13	5 ^{1/8} "x5 ^{1/8} "	10	0,17	3,5	-	-	-
distorsion	13x13	5 ^{1/8} "x5 ^{1/8} "	10	0,17	3,5	-	-	-
double tune	10x40	4"x16"	4	0,16	3,2	-	-	-
single tune	10x40	4"x16"	4	0,16	3,2	-	-	-

GOUACHE.10 SLIMTECH

articolo			scatola			europallet		
	cm	inch	pz.	mq	kg	scat.	mq	kg
fondo 3mm	100x300	39"x118"	1	3,0	22,2	13 pz/pl	39,0	288,6
fondo 3plus	100x300	39"x118"	1	3,0	25,3	12 pz/pl	36,0	304,2
fondo 3plus	100x100	39"x39"	3	3,0	24,1	25	75,0	602,5
fondo 3mm	50x100	19 ^{1/2} "x39"	5	2,5	17,8	32	80,0	569,6
fondo 3plus	50x100	19 ^{1/2} "x39"	5	2,5	20,0	32	80,0	640,0
fondo 3plus	50x50	19 ^{1/2} "x19 ^{1/2} "	7	1,75	14,0	48	84,0	672,0
fondo 3plus	4,9x100	2"x39"	10	0,49	4,2	39	19,1	163,8
decoro libeccio	15,4x22,3	6 ^{1/8} "x8 ^{3/4} "	10	0,34	2,8	80	27,47	224,0

KALOS

articolo			scatola			europallet		
	cm	inch	pz.	mq	kg	scat.	mq	kg
fondo	35x100	13 ^{3/4} "x39"	3	1,05	22,0	26	27,3	570,7
fondo	35x35	13 ^{3/4} "x13 ^{3/4} "	9	1,10	21,2	24	26,4	508,8
ramage	35x100	13 ^{3/4} "x39"	3	1,05	21,4	8	8,4	171,4
strip	35x100	13 ^{3/4} "x39"	3	1,05	21,4	8	8,4	171,4
lesena	17,5x100	6 ^{7/8} "x39"	6	1,05	22,2	12	12,6	266,4
listello	7x35	2 ^{3/4} "x13 ^{3/4} "	8	0,20	3,7	90	17,6	331,2
ang. listello	7x2	2 ^{3/4} "x3/4"	4	-	0,1	-	-	-
battiscopa	12,5x35	5"x13 ^{3/4} "	10	3,5 m.l.	7,0	48	168 m.l.	336,0
ang. battiscopa	12,5x2	5"x3/4"	4	-	0,2	-	-	-
chair rail	4x35	1 ^{9/16} "x13 ^{3/4} "	10	0,14	4,0	-	-	-
ang. chair rail	4x2	1 ^{9/16} "x3/4"	4	-	0,1	-	-	-
liner	1,5x35	5/8"x13 ^{3/4} "	16	0,08	2,24	-	-	-
ang. liner	1,5x2	5/8"x3/4"	4	-	0,1	-	-	-
raccordo jolly	1,5x35	5/8"x13 ^{3/4} "	16	0,08	1,3	-	-	-
beak	1,5x1,2	5/8"x1/2"	4	-	0,1	-	-	-

KENSINGTON

articolo			scatola			europallet		
	cm	inch	pz.	mq	kg	scat.	mq	kg
fondo	31x62	12 ^{1/4} "x24 ^{1/2} "	6	1,15	19,6	40	46,1	784,0
fondo	31x31	12 ^{1/4} "x12 ^{1/4} "	13	1,25	21,3	50	62,5	1062,5
plank	31x62	12 ^{1/4} "x24 ^{1/2} "	6	1,15	19,6	40	46,1	784,0
jewel	31x62	12 ^{1/4} "x24 ^{1/2} "	4	0,77	15,9	40	30,8	635,2
brick	31x62	12 ^{1/4} "x24 ^{1/2} "	6	1,15	19,6	40	46,1	784,0
square	31x62	12 ^{1/4} "x24 ^{1/2} "	5	0,96	18,5	40	38,4	740,0
cornice in legno	9x62	3 ^{1/2} "x24 ^{1/2} "	6	3,72 m.l.	0,25	-	-	-
listello decò	7,5x31	3"x12 ^{1/4} "	12	0,28	4,8	-	-	-
girosp specchio decò	7,5x7,5	3"x3"	4	-	0,4	-	-	-
raccordo jolly	1,3x31	1/2"x12 ^{1/4} "	9	-	0,9	-	-	-
beak	1,3x1,3	1/2"x1/2"	4	-	-	-	-	-

Imballi

packing / emballage

verpackung / embalajes

LINES SLIMTECH

articolo			scatola			europallet		
	cm	inch	pz.	mq	kg	scat.	mq	kg
fondo 3plus	100x300	39"x118"	1	3,00	25,4	12 pz/pl	36,0	304,2

MAKÒ

articolo			scatola			europallet		
	cm	inch	pz.	mq	kg	scat.	mq	kg
fondo	60x60	24"x24"	4	1,44	35,0	24	34,6	840,0
fondo	30x60	12"x24"	8	1,44	34,9	32	46,1	1116,8
fondo	9,7x60	3 ³ / ₄ "x24"	13	0,76	19,2	60	45,4	1152,0
fondo	2x60	3/4"x24"	12	0,14	3,5	-	-	-
fondo	2x2	3/4"x3/4"	12	-	-	-	-	-
decoro pin striped	30x60	12"x24"	4	0,72	17,2	36	25,9	619,2
decoro wallflower	30x60	12"x24"	4	0,72	17,2	48	34,6	825,6
decoro tartan	30x60	12"x24"	4	0,72	17,2	48	34,6	825,6
decoro cross	30x60	12"x24"	4	0,72	17,2	30	21,6	516,0
decoro wallpaper	20x60	8"x24"	4	0,48	11,44	60	28,8	686,4
decoro corset	30x30	12"x12"	6	0,54	13,1	35	18,9	457,8
decoro brocade	3x60	1 ³ / ₁₆ "x24"	12	0,22	5,16	-	-	-
decoro twill	3x60	1 ³ / ₁₆ "x24"	10	0,18	7,5	-	-	-
battiscopa	10x60	4"x24"	12	7,2 m.l.	18,0	55	396,0 m.l.	990,0
gradino step	60x60	24"x24"	4	1,44	35,0	24	34,6	840,0
beak jolly	1,3x1,3	1/2"x1/2"	4	-	-	-	-	-
raccordo jolly	1,3x30	1/2"x12"	8	0,03	0,3	-	-	-

MAUK SLIMTECH

articolo			scatola			europallet		
	cm	inch	pz.	mq	kg	scat.	mq	kg
cuadra 3plus	57,6	22 ⁵ / ₈ "	6	1,73	15,5	5	8,6	77,5
esa 3plus	38,3	15 ¹ / ₈ "	12	0,77	6,4	20	15,4	127,0
spina 3mm	25,8x13,5x8,7	10 ¹ / ₈ "x5 ³ / ₈ "x3 ³ / ₈ "	15	0,18	1,5	80	14,8	120,0

MAYFAIR

articolo			scatola			europallet		
	cm	inch	pz.	mq	kg	scat.	mq	kg
fondo	31x62	12 ¹ / ₄ "x24 ¹ / ₂ "	6	1,15	19,6	40	46,1	784,0
fondo	31x31	12 ¹ / ₄ "x12 ¹ / ₄ "	13	1,25	21,3	50	62,5	1062,5
jewel	31x62	12 ¹ / ₄ "x24 ¹ / ₂ "	4	0,77	15,9	40	30,8	635,2
decoro palace/palace lux	31x62	12 ¹ / ₄ "x24 ¹ / ₂ "	4	0,77	13,2	24	18,5	316,8
decoro style/style lux	15x62	6"x24 ¹ / ₂ "	6	0,58	12,0	32	18,5	384,0
mosaico palace/style	31x31	12 ¹ / ₄ "x12 ¹ / ₄ "	5	0,48	8,5	60	28,8	510,0
fascia palace	6x31	2 ³ / ₈ "x12 ¹ / ₄ "	12	0,22	4,8	-	-	-
bacchetta silver	2,5x31	1"x12 ¹ / ₄ "	24	0,19	3,4	-	-	-
bacchetta palace/gold	2,5x62	1"x24 ¹ / ₂ "	10	0,16	3,0	-	-	-
bacchetta platinum	1x62	3/8"x24 ¹ / ₂ "	10	0,06	1,4	-	-	-
raccordo jolly	2x31	3/4"x12 ¹ / ₄ "	9	-	0,1	-	-	-
beak	2x2	3/4"x3/4"	4	-	-	-	-	-

METROPOLIS

articolo			scatola			europallet		
	cm	inch	pz.	mq	kg	scat.	mq	kg
fondo spess 11	90x90	36"x36"	2	1,62	40,0	24	38,9	960,0
fondo spess 11	45x90	18"x36"	3	1,22	30,0	27	32,8	810,0
fondo spess 11	75x75	30"x30"	2	1,13	27,4	40	45,0	1096,0
fondo spess 10	60x60	24"x24"	4	1,44	32,0	32	46,1	1024,0
fondo spess 10	30x60	12"x24"	8	1,44	32,0	32	46,1	1024,0
muretto urban	30x60	12"x24"	4	0,72	15,6	30	21,6	468,0
muretto avenue 3D	30x60	12"x24"	4	0,72	18,2	30	21,6	546,0
bacchetta metal	1,5x60	5/8"x24"	15	0,14	4,5	-	-	-
battiscopa	10x60	4"x24"	12	7,2 m.l.	18,0	50	360,0 m.l.	900,0
gradino plus	35x60	13 ³ / ₄ "x24"	4	0,84	21,2	24	20,2	508,8
angolo gradino plus	35x35	13 ³ / ₄ "x13 ³ / ₄ "	4	0,49	13,4	30	14,7	402,0

ORIGINI

articolo			scatola			europallet		
	cm	inch	pz.	mq	kg	scat.	mq	kg
fondo	60x120	24"x48"	2	1,44	35,5	24	34,6	852,0
fondo	30x120	12"x48"	3	1,08	25,5	32	34,6	816,0
fondo	60x60	48"x48"	4	1,44	35,5	32	46,1	1136,0
fondo	30x60	12"x24"	8	1,44	35,5	32	46,1	1136,0
twist	30x120	12"x48"	2	0,72	17,0	40	28,8	680,0
chain	30x60	12"x24"	4	0,72	16,8	20	14,4	336,0
barrè	30x60	12"x24"	4	0,72	19,2	40	28,8	768,0
gran damier	30x30	12"x12"	6	0,54	14,4	60	32,4	864,0
tweed	30x30	12"x12"	8	0,72	19,2	60	43,2	1152,0
bacchetta metal	1,5x60	5/8"x24"	15	0,14	4,5	-	-	-
gradino plus lux /nat.	35x120	13 ³ / ₄ "x48"	2	0,84	21,3	24	20,2	511,2
gradino plus grip	35x60	13 ³ / ₄ "x24"	2	0,42	10,7	24	10,1	256,8
ang. gradino plus lux /nat.	35x120	13 ³ / ₄ "x48"	1	0,42	11,5	24	10,1	276,0
ang. gradino plus grip	35x35	13 ³ / ₄ "x13 ³ / ₄ "	4	0,49	13,4	30	14,7	402,0
battiscopa lux /nat.	10x60	4"x24"	12	7,2 m.l.	18,0	56	403,0 m.l.	1008,0
raccordo jolly	1,3x30	1/2"x12"	16	-	1,3	-	-	-
beak jolly	1,3x2	1/2"x3/4"	4	-	0,1	-	-	-

OUTDOOR

articolo			scatola			europallet		
	cm	inch	pz.	mq	kg	scat.	mq	kg
fondo	20x40,4	8"x16"	13	1,05	21,1	54	56,7	1139,4
fondo	20x30,2	8"x12"	20	1,21	24,2	48	58,0	1161,6
fondo	20x20	8"x8"	30	1,20	24,0	45	54,0	1080,0
battiscopa	10x30,2	4"x12"	28	8,5 m.l.	17,0	33	279,0 m.l.	561,0
elemento elle cont.	4x12x30,2	1 ⁹ / ₁₆ "x4 ³ / ₄ "x12"	8	0,29	8,0	28	8,1	224,0

PAILLETES

articolo			scatola			europallet		
	cm	inch	pz.	mq	kg	scat.	mq	kg
fondo	30x32	12"x12 ¹ / ₂ "	10	0,96	12,5	26	25,0	325,0
decoro bandiera	30x32	12"x12 ¹ / ₂ "	4	0,38	5,3	26	10,0	137,8
decoro camelia	30x32	12"x12 ¹ / ₂ "	4	0,38	5,3	26	10,0	137,8

Imballi

packing / emballage
verpackung / embalajes

PLEASURES

articolo			scatola			europallet		
	cm	inch	pz.	mq	kg	scat.	mq	kg
fondo	35x70	13 ³ / ₄ "x27 ¹ / ₂ "	4	0,98	18,1	56	54,9	1013,6
fondo	35x35	13 ³ / ₄ "x13 ³ / ₄ "	9	1,10	21,3	24	26,4	511,2
decoro juicy	35x70	13 ³ / ₄ "x27 ¹ / ₂ "	4	0,98	18,1	-	-	-
liner	2x35	3/4"x13 ³ / ₄ "	12	0,08	1,2	-	-	-
angolo liner	1x2	3/8"x3/4"	4	-	-	-	-	-
chair rail	7x35	2 ³ / ₄ "x13 ³ / ₄ "	10	0,25	6,0	-	-	-
angolo chiar rail	2x7	3/4"x2 ³ / ₄ "	4	-	0,1	-	-	-
raccordo jolly	2x35	3/4"x13 ³ / ₄ "	12	0,08	1,2	-	-	-
beak	2x2	3/4"x3/4"	4	-	0,1	-	-	-

PROGETTO L14

articolo			scatola			europallet		
	cm	inch	pz.	mq	kg	scat.	mq	kg
fondo double	20x40	8"x16"	21	1,68	25,5	48	80,6	1225,9
fondo	10x40	4"x16"	18	0,72	11,1	60	43,2	666,0
fondo	20x40	8"x16"	21	1,68	28,4	48	80,6	1363,2
fondo preinciso	20x40	8"x16"	12	0,96	14,5	36	34,6	522,4
listello	3x40	1 ³ / ₁₆ "x16"	24	0,29	5,0	-	-	-
decoro spy	10x40	4"x16"	6	0,24	3,8	-	-	-
decoro roads	10x40	4"x16"	6	0,24	3,8	-	-	-
decoro soft	10x40	4"x16"	6	0,24	3,8	-	-	-
decoro record	10x40	4"x16"	12	0,48	7,6	-	-	-

RAIN FOREST

articolo			scatola			europallet		
	cm	inch	pz.	mq	kg	scat.	mq	kg
fondo	48,5x48,5	19"x19"	6	1,41	31,6	24	33,9	758,4
fondo	32,2x48,5	12 ⁵ / ₈ "x19"	7	1,10	23,1	44	48,1	1016,4
fondo	32,2x32,2	12 ⁵ / ₈ "x12 ⁵ / ₈ "	12	1,25	28,0	42	52,3	1176,0
fondo	15,9x15,9	6 ¹ / ₄ "x6 ¹ / ₄ "	48	1,21	27,0	48	58,2	1296,0
mosaico 6	32,2x32,2	12 ⁵ / ₈ "x12 ⁵ / ₈ "	5	0,52	10,0	60	31,1	600,0
battiscopa	8x32,2	3 ¹ / ₈ "x12 ⁵ / ₈ "	44	11,3 m.l.	23,0	20	226,7 m.l.	460,0
gradino step	32,2x32,2	12 ⁵ / ₈ "x12 ⁵ / ₈ "	12	1,24	28,0	42	52,2	1174,3
elemento elle continuo	15x32,2x5	6"x12 ⁵ / ₈ "x2"	8	0,39	12,0	-	-	-
torello gradino bordo	5,5x32,2	2 ¹ / ₈ "x12 ⁵ / ₈ "	6	-	3,0	-	-	-
torello gradino angolo	5,5x32,2	2 ¹ / ₈ "x12 ⁵ / ₈ "	2	-	2,0	-	-	-
quarter round	2,8x6	1 ¹ / ₈ "x2 ³ / ₈ "	32	-	0,7	-	-	-
beak	2,8x2,8	1 ¹ / ₈ "x1 ¹ / ₈ "	20	-	-	-	-	-

RE-evolution SLIMTECH

articolo			scatola			europallet		
	cm	inch	pz.	mq	kg	scat.	mq	kg
fondo 3mm	100x300	39"x118"	1	3	22,2	13 pz/pl	39,0	288,6
fondo 3plus	100x300	39"x118"	1	3	25,35	12 pz/pl	36,0	304,2
fondo 3plus	100x100	39"x39"	3	3	24,10	25	75,0	602,5
fondo 3mm	50x100	19 1/2"x39"	5	2,5	17,8	32	80,0	569,6
fondo 3plus	50x100	19 1/2"x39"	5	2,5	20,0	32	80,0	640,0
fondo 3plus	50x50	19 1/2"x19 1/2"	7	1,75	14,0	48	84,0	672,0
fondo 3plus	4,9x100	2"x39"	10	0,49	4,2	39	19,11	163,8
muretto mix	25x30	10"x12"	12	0,90	6,6	60	54,0	397,2
composizione listello	25x25	10"x10"	12	0,75	5,5	60	45,0	331,2
cornice	5,5x50	2 1/8"x19 1/2"	6	0,17	2,4	-	-	-
battiscopa	12x50	4 3/4"x19 1/2"	6	3,0 m.l.	4,2	-	-	-

SALENTO

articolo			scatola			europallet		
	cm	inch	pz.	mq	kg	scat.	mq	kg
fondo spess 11	75x75	30"x30"	2	1,12	27,4	40	45,0	1096,0
fondo spess 11	37,5x75	15"x30"	5	1,41	34,3	32	45,0	1096,0
fondo spess 10	60x60	24"x24"	4	1,44	32,0	32	46,1	1024,0
fondo spess 10	60,4x60,4	24"x24"	4	1,46	32,0	32	46,7	1024,0
fondo spess 10	30x60	12"x24"	8	1,44	32,0	32	46,1	1024,0
fondo spess 10	30x60,4	12"x24"	8	1,45	32,0	32	46,3	1024,0
muretto	30x60	12"x24"	4	0,72	15,6	30	21,6	468,0
mosaico	30x30	12"x12"	5	0,45	10,0	60	27,0	600,0
mosaico mattone	30x30	12"x12"	5	0,45	10,0	60	27,0	600,0
battiscopa	10x60	4"x24"	12	7,2 m.l.	18,0	-	-	-
gradino step	60x60	24"x24"	4	1,44	36,0	-	-	-

SHADE SLIMTECH

articolo			scatola			europallet		
	cm	inch	pz.	mq	kg	scat.	mq	kg
fondo 3mm	100x300	39"x118"	1	3	22,2	13 pz/pl	39,0	288,6
fondo 3plus	100x300	39"x118"	1	3	25,35	12 pz/pl	36,0	304,2
fondo 3plus	100x100	39"x39"	3	3	24,10	25	75,0	602,5
fondo 3mm	50x100	19 1/2"x39"	5	2,5	17,8	32	80,0	569,6
fondo 3plus	50x100	19 1/2"x39"	5	2,5	20,0	32	80,0	640,0
fondo 3plus	50x50	19 1/2"x19 1/2"	7	1,75	14,0	48	84,0	672,0
fondo 3plus	4,9x100	2"x39"	10	0,49	4,2	39	19,11	163,8
muretto wall	25x30	10"x12"	12	0,9	6,6	60	54,0	397,2

Imballi

packing / emballage

verpackung / embalajes

STONEHENGE

articolo			scatola			europallet		
	cm	inch	pz.	mq	kg	scat.	mq	kg
fondo	75x75	30"x30"	2	1,12	27,4	40	45,0	1096,0
fondo	60x60	24"x24"	4	1,44	35,0	24	34,6	840,0
fondo	30x60	12"x24"	8	1,44	34,9	32	46,1	1116,8
fondo	9,7x60	3 ^{3/4} "x24"	13	0,76	19,2	60	45,4	1152,0
fondo	5,7x60	2 ^{1/4} "x24"	13	0,44	11,3	80	35,6	904,0
mosaico	30x30	12"x12"	5	0,45	10,5	60	27,0	630,0
composizione listello	30x30	12"x12"	6	0,54	13,3	42	22,7	559,4
listello metallo 30	1,5x30	5/8"x12"	6	0,03	0,6	-	-	-
listello metallo 60	1,5x60	5/8"x24"	6	0,05	1,1	-	-	-
battiscopa	8x60	3 ^{1/8} "x24"	12	7,2 m.l.	18,0	50	360,0 m.l.	900,0
gradino	60x60	24"x24"	4	1,44	35,0	24	34,6	840,0
gradino continuo 60	5x32,5x60	2"x12 ^{3/4} "x24"	4	0,78	19,2	-	-	-
ang. gradino continuo	5x32,5x32,5	2"x12 ^{3/4} "x12 ^{3/4} "	2	0,21	5,5	14	3,0	76,4
jolly metallo	1,3x30	1/2"x12"	6	0,23	1,8	-	-	-
beak metallo	1,3x1,3	1/2"x1/2"	4	-	-	-	-	-
raccordo jolly	1,3x30	1/2"x12"	8	0,03	0,3	-	-	-
beak	1,3x1,3	1/2"x1/2"	4	-	-	-	-	-

STORM

articolo			scatola			europallet		
	cm	inch	pz.	mq	kg	scat.	mq	kg
fondo	60x60	24"x24"	4	1,44	35,0	24	34,6	840,0
fondo	30x60	12"x24"	8	1,44	34,9	32	46,1	1116,8
fondo	30x30	12"x12"	11	0,99	22,9	40	39,6	917,2
fondo	30x60,4	12"x24"	9	1,63	32,4	32	52,2	1036,8
fondo spess 11	60x60	24"x24"	4	1,44	35,0	24	34,6	840,0
fondo spess 9	45x45	18"x18"	7	1,42	28,0	52	73,7	1456,0
fondo spess 9	30x30	12"x12"	15	1,35	26,2	40	54,0	1048,0
link	30x60	12"x24"	4	0,72	17,0	40	28,8	680,0
mosaico 3	30x30	12"x12"	5	0,45	9,2	60	27,0	552,0
mosaico 10	30x30	12"x12"	5	0,45	12,5	60	27,0	750,0
muretto	30x60	12"x24"	4	0,72	15,9	30	21,6	477,0
muretto 3D	15x60	6"x24"	8	0,72	17,8	30	21,6	534,0
battiscopa	10x60	4"x24"	12	7,2 m.l.	18	50	360,0 m.l.	900,0
gradino	60x60	24"x24"	4	1,44	35	24	34,6	840,0
elemento elle continuo	15x30x5	6"x12"x2"	8	0,36	8,8	28	10,1	246,4
gradino continuo	5x32,5x60	2"x12 ^{3/4} "x24"	4	0,78	19,2	14	10,9	268,8
ang. gradino continuo	5x32,5x32,5	2"x12 ^{3/4} "x12 ^{3/4} "	2	0,21	5,5	14	3,0	76,4

STUDIES IN GOUACHE SLIMTECH

articolo			scatola			europallet		
	cm	inch	pz.	mq	kg	scat.	mq	kg
decoro grid 3plus	50x100	19 ^{1/2} "x39"	3	1,50	11,0	30	45,0	330,0
decoro knit 3plus	50x100	19 ^{1/2} "x39"	3	1,50	11,0	30	45,0	330,0
decoro moire b 3plus	50x100	19 ^{1/2} "x39"	3	1,50	11,0	30	45,0	330,0
decoro scratch 3plus	50x100	19 ^{1/2} "x39"	3	1,50	11,0	30	45,0	330,0

STREETS IN SHADE SLIMTECH

articolo			scatola			europallet		
	cm	inch	pz.	mq	kg	scat.	mq	kg
decoro streets 3mm	50x100	19 1/2"x39"	2	1,0	7,1	30	30,0	213,6

TECNOQUARTZ

articolo			scatola			europallet		
	cm	inch	pz.	mq	kg	scat.	mq	kg
fondo	60x120	24"x48"	2	1,44	40,8	24	34,6	979,2
fondo	60x60	24"x24"	4	1,44	36,6	24	34,6	879,4
fondo	40x60	16"x24"	4	0,96	24,6	24	23,0	589,4
fondo	30x60	12"x24"	7	1,26	32,5	32	40,3	1040,0
fondo	20x60	8"x24"	7	0,84	21,2	48	40,3	1017,6
fondo	30x30	12"x12"	12	1,08	27,2	40	43,2	1089,6
fondo	20x30	8"x12"	12	0,72	17,8	60	43,2	1065,6
fondo anticato	14,5x14,5	5 3/4"x5 3/4"	31	0,65	17,5	64	41,7	1120,0
fondo anticato	7,1x14,5	2 3/4"x5 3/4"	62	0,64	17,5	64	40,8	1120,0
listone link	30x60	12"x24"	4	0,72	17,9	40	28,8	716,0
mosaico anticato 7	29,3x29,3	11 1/2"x11 1/2"	5	0,43	10,5	60	25,7	630,0
muretto	30x60	12"x24"	4	0,72	17,9	30	21,6	537,0
listello righe	6,5x30	2 1/2"x12"	12	0,23	5,2	-	-	-
angolo listello righe	2x6,5	3/4"x2 1/2"	4	-	-	-	-	-
tozzetto righe	6,5x6,5	2 1/2"x2 1/2"	4	-	0,4	-	-	-
battiscopa	8x30	3 1/8"x12"	22	6,6 m.l.	15,8	77	508,2 m.l.	1219,7
gradino plus	35x60	13 3/4"x24"	4	0,84	25,6	24	20,2	614,4
ang. gradino plus	35x35	13 3/4"x13 3/4"	4	0,49	16,0	30	14,7	480,0
elemento elle continuo	5x15x30	2"x6"x12"	8	0,36	12,1	-	-	-
matita	3x30	1 3/16"x12"	12	0,11	2,7	-	-	-
angolo matita	1,5x3	5/8"x1 3/16"	4	-	-	-	-	-
torello	5x30	2"x12"	12	0,18	4,2	-	-	-
angolo torello	1,5x5	5/8"x2"	4	-	0,1	-	-	-
raccordo jolly	1,3x30	1/2"x12"	8	-	0,3	-	-	-
beak jolly	1,3x1,3	1/2"x1/2"	4	-	-	-	-	-

TESSERAE

articolo			scatola			europallet		
	cm	inch	pz.	mq	kg	scat.	mq	kg
quadro	30,5x30,5	12"x12"	5	0,45	3,7	144	67,0	540,0
domino	30,5x30,5	12"x12"	5	0,45	3,7	144	67,0	540,0
muretto	30,5x30,5	12"x12"	5	0,45	3,7	144	67,0	540,0
muretto 3D	30,5x30,5	12"x12"	5	0,47	5,0	-	-	-
mosaico quadro 3D	30,5x30,5	12"x12"	5	0,47	5,0	-	-	-
listello	2x15	3/4"x6"	16	0,05	2,4	-	-	-
chair rail	1,5x15	5/8"x6"	20	0,04	1,2	-	-	-

Imballi

packing / emballage
verpackung / embalajes

TRÈS JOLIE

articolo			scatola			europallet		
	cm	inch	pz.	mq	kg	scat.	mq	kg
damier	35x70	13 ³ / ₄ "x27 ¹ / ₂ "	4	0,98	18,1	6	5,9	108,5
pois	35x70	13 ³ / ₄ "x27 ¹ / ₂ "	4	0,98	18,1	6	5,9	108,5
capitoné	35x70	13 ³ / ₄ "x27 ¹ / ₂ "	4	0,98	19,4	8	7,8	155,2
damas	35x70	13 ³ / ₄ "x27 ¹ / ₂ "	4	0,98	18,1	6	5,9	108,5
listello parisienne	1,5x35	5/8"x13 ³ / ₄ "	6	0,03	0,63	-	-	-
fascia parisienne	5x35	2"x13 ³ / ₄ "	6	0,10	2,1	-	-	-
fascia passepartout	2x35	3/4"x13 ³ / ₄ "	12	0,08	1,17	-	-	-

TYPE-32 SLIMTECH

articolo			scatola			europallet		
	cm	inch	pz.	mq	kg	scat.	mq	kg
fondo 5plus	20x200	8"x79"	3	1,20	15,0	40	48,0	600,0

WAVES SLIMTECH

articolo			scatola			europallet		
	cm	inch	pz.	mq	kg	scat.	mq	kg
fondo 3plus	100x300	39"x118"	1	3,00	25,3	12 pz/pl	36,0	304,2

WOOD-STOCK SLIMTECH

articolo			scatola			europallet		
	cm	inch	pz.	mq	kg	scat.	mq	kg
fondo 5plus	33x300	13"x118"	1	0,99	12,5	24 pz/pl	23,8	299,7
fondo 5plus	20x200	8"x79"	3	1,20	15,0	40	48,0	600,0
fondo 5plus	20x150	8"x59"	3	0,90	11,3	60	54,0	675,0
fondo 5plus	20x100	8"x39"	3	0,60	7,5	60	36,0	450,0

Nota relativa agli imballi

Tutti i dati relativi gli imballi indicati nel presente catalogo sono da ritenersi puramente indicativi e potrebbero subire variazioni.

Information regarding packaging

All information regarding packaging in this catalogue are considered purely indicative and subject to change.

Note informative concernant les emballages

Les valeurs des emballages déclarées sur ce catalogue sont purement indicatives et elles pourront être modifiées.

Kennzeichen fuer die Verpackungseinheiten

Die Angaben diesen Verpackungen sind rein indikativ und koennen veraendert werden.

Nota informativa relativa a los imballages

Todos los datos relativos a los embalajes indicados en la presente catalogo se retienen puramente indicativos y podrían sufrir variaciones.

Nota relativa al prodotto

Tutte le informazioni relative al prodotto possono subire variazioni in ordine a migliorie dello stesso.

Information regarding product

All product information can be modified in order to improve it.

Note informative concernant le produit

Toutes les informations relatives au produit peuvent subir des variations suite à des améliorations de celui-ci.

Kennzeichen fuer die Produkte

Alle Produktinformationen können geändert werden, um es zu verbessern.

Nota informativa relativa a el producto

Todas las informaciones relativas al producto pueden sufrir variaciones en pedido a mejora del mismo.

CONDIZIONI GENERALI DI VENDITA

1 - Applicabilità delle condizioni.

1.1. Le presenti condizioni generali (qui di seguito "le CONDIZIONI") costituiscono parte integrante di tutti i contratti di vendita delle piastrelle ed altro materiale ceramico (qui di seguito "i/i PRODOTTI") in cui sia parte la Panariagroup Industrie Ceramiche S.p.A. – divisione Lea Ceramiche (qui di seguito "il FABBRICANTE"). Salvo singoli casi in cui esse siano state derogate con espresse pattuizioni scritte a firma del FABBRICANTE, esse costituiranno la disciplina esclusiva di tali vendite. Se una o più parti delle presenti CONDIZIONI o dei singoli contratti che le includono risultassero invalide, le CONDIZIONI generali o particolari resteranno valide nel loro complesso; le parti invalide saranno sostituite con pattuizioni che si avvicinino quanto possibile alla originaria volontà delle parti.

2 - Conclusione del contratto di vendita – Consegna dei prodotti.

2.1. Il contratto si intende concluso al momento in cui il proponente o l'ordinante vengano a conoscenza del consenso scritto della controparte. 2.2. L'ordine non confermato per iscritto in nessun caso potrà intendersi accettato salvo esecuzione del medesimo da parte del FABBRICANTE mediante spedizione o consegna dei PRODOTTI. La consegna parziale di PRODOTTI ordinati non comporta l'accettazione dell'intero ordine, ma solo di quella parte di PRODOTTI effettivamente consegnata. 2.3. Salvo diverso accordo scritto, la consegna dei PRODOTTI e la resa degli stessi in Italia e all'estero avverrà secondo la formula "Franco Fabbrica". Tale formula, come anche nelle formule di resa che fossero convenute per iscritto in alternativa ad essa, fanno riferimento agli "Incoterms" della Camera di Commercio Internazionale di Parigi, nella edizione vigente al momento della vendita. 2.4. Salvo diverso accordo, tutte le date indicate come termine di consegna si intendono a titolo indicativo.

3 - Caratteristiche dei prodotti – Garanzia – Reclami.

3.1. Le piastrelle in ceramica ed altri PRODOTTI ceramici fabbricati dalle Panariagroup Industrie Ceramiche S.p.A. – divisione Lea Ceramiche, sono conformi alle norme europee UNI-DIN-EN. Il FABBRICANTE vende esclusivamente a rivenditori professionali; questi sono responsabili della correttezza delle informazioni tecniche fornite agli utilizzatori finali e/o ai negozi al dettaglio. La classificazione del prodotto è indicata dal FABBRICANTE sul materiale pubblicitario e/o sui listini prezzi, l'Acquirente deve di conseguenza utilizzare i PRODOTTI sulla base della classificazione fornita dal FABBRICANTE. Per facilitare le indicazioni di utilizzo, ed adattare le classificazioni standard alle specificità della produzione del FABBRICANTE, a fronte di ogni prodotto, nei listini o sui cataloghi sono posti dei segni che indicano l'uso specifico consigliato dal FABBRICANTE. 3.2. Le differenze di tonalità non sono un difetto del PRODOTTO bensì una caratteristica dello specifico materiale cotto ad alte temperature. Il particolare requisito di ingelività si applica solo ai PRODOTTI che il FABBRICANTE garantisce espressamente con apposita indicazione sul materiale pubblicitario e/o listini. In mancanza di tale indicazione i materiali ceramici si considerano solo ed unicamente per uso in interni o comunque in locali protetti dalle intemperie. La garanzia di ingelività ha una durata di due anni. 3.3. I materiali in ceramica con superficie lucida non possono mai essere utilizzati in locali a piano terreno con accesso all'esterno, né in locali in cui sia previsto un grande calpestio. Le piastrelle brillanti sono inoltre suscettibili di una certa scivolosità, specialmente se bagnate: il FABBRICANTE ne sconsiglia di conseguenza l'uso in locali pubblici. Per i locali ove sia previsto un grande calpestio l'acquirente dovrà acquistare solo i PRODOTTI classificati dal FABBRICANTE come PEI V, ed in particolare quelle piastrelle che il FABBRICANTE consiglia specificatamente per uso in locali pubblici. 3.4. Le rappresentazioni dei PRODOTTI sui depliant ed altri materiali pubblicitari del FABBRICANTE sono puramente illustrative e non rappresentano necessariamente il risultato estetico finale di posa dello specifico PRODOTTO rappresentato. 3.5. Il FABBRICANTE garantisce la buona qualità e l'assenza di vizi nei PRODOTTI forniti. La garanzia non si applica per PRODOTTI classificati dal FABBRICANTE per qualità inferiori alla 1^ scelta o per partite di PRODOTTI di fine serie, vendute in blocco e segnalate come partite speciali. 3.6. Il FABBRICANTE non è responsabile per vizi e/o anomalie rilevate sui PRODOTTI non dovuti alla qualità dei PRODOTTI stessi ma all'uso improprio degli stessi da parte degli acquirenti e/o dei suoi aventi causa. In particolare, il FABBRICANTE non accetta reclami o contestazioni in relazione alle situazioni precedentemente descritte. 3.7. I reclami devono essere comunicati dall'acquirente al FABBRICANTE per iscritto entro 8 giorni dalla consegna della merce. Per i vizi occulti il termine è di 8 giorni dalla scoperta del vizio. In nessun caso il FABBRICANTE risponderà per vizi che vengano denunciati dopo 12 mesi dalla consegna dei Prodotti al primo acquirente del FABBRICANTE. A tal fine, in esplicita deroga a quanto previsto dall'art. 1519-quinquies cod.civ., il rivenditore potrà esercitare l'azione di regresso contro il FABBRICANTE esclusivamente entro il termine di 1 anno dalla consegna dei Prodotti. 3.8. In generale la garanzia si applica solo per vizi rilevati in prodotti non ancora posati. Per eventuali vizi occulti rilevabili solo successivamente alla posa, ai fini dell'applicazione della garanzia, è necessario che il FABBRICANTE accerti che la posa sia stata eseguita a regola d'arte (norme DIN 18352). 3.9. La garanzia del FABBRICANTE si limita alla sostituzione dei prodotti difettosi con altri dello stesso tipo esenti da vizi, trasporto incluso. E' escluso il rimborso di altri oneri e/o spese accessorie e, in particolare, i costi di demolizione e riposatura dei PRODOTTI. In tutti i casi la garanzia del FABBRICANTE non potrà eccedere cinque volte il valore del materiale contestato, con un massimo assoluto di € 10.000,00. 3.10. Il FABBRICANTE non risponde per reclami dovuti ad una classificazione del materiale ceramico da parte di organismi di controllo e/o certificazione diversi da quelli europei di cui al punto 3.1 sulla base di specifiche tecniche che non corrispondano a quelle utilizzate dal FABBRICANTE. Eventuali expertise tecnici attivati dagli acquirenti dovranno necessariamente basarsi sulla conformità del materiale venduto alle specifiche tecniche indicate dal FABBRICANTE, in vigore in Italia.

4 - Prezzi e condizioni di pagamento.

4.1. I prezzi di vendita dei PRODOTTI sono quelli indicati nel listino del FABBRICANTE E in vigore al momento della conferma dell'ordine. In casi di contratti di vendita a consegne ripartite il prezzo, se non convenuto fermo per iscritto, sarà quello del listino prezzi in vigore al momento delle singole consegne. Per tutti i PRODOTTI destinati all'estero i prezzi potranno essere calcolati, a scelta del FABBRICANTE, nella valuta estera del paese di destinazione o in €. 4.2. Salvo diverso accordo, i pagamenti sono da effettuarsi dall'Acquirente, tramite bonifico bancario, entro 30 giorni data fattura. Tutte le spese bancarie e di negoziazione sono a carico dell'Acquirente. In caso di ritardo nei pagamenti, il FABBRICANTE avrà diritto a percepire, senza alcuna necessità di messa in mora, oltre agli eventuali danni, gli interessi moratori così come determinati dall'art.5 del D. Lgs. n.231/2002.

5 - Agenti del fabbricante.

5.1. Gli agenti del FABBRICANTE promuovono le vendite e non sono autorizzati ad agire in nome e per conto del FABBRICANTE salvo specifica autorizzazione scritta. 5.2. Gli ordini trasmessi dagli agenti non vincolano il FABBRICANTE e devono quindi essere espressamente accettati per iscritto dal FABBRICANTE stesso.

6 - Riservato dominio.

6.1. E' convenuto tra le parti che la vendita dei PRODOTTI è effettuata con riserva di proprietà a favore del FABBRICANTE sino al totale pagamento del prezzo pattuito, ai sensi dell'art. 1523 e seguenti del codice Civile Italiano. Tuttavia il rischio di perimento della merce passa all'Acquirente dal momento della consegna dei PRODOTTI. Nelle vendite all'estero, nel caso in cui la merce sia venduta e consegnata a clienti terzi prima del passaggio di proprietà, nell'ambito di normali rapporti commerciali dell'Acquirente stesso, la riserva di proprietà a favore del FABBRICANTE permane anche nei confronti dei terzi, ove la legge lo consenta. 6.2. In caso di mora dell'Acquirente il FABBRICANTE potrà, senza necessità di alcuna formalità, compresa la messa in mora, ritirare tutta la merce oggetto di riservato dominio ed eventualmente, se la legge lo consente, tutti i titoli di credito verso terzi ad essa afferenti, con riserva di ogni ulteriore opportuno rimedio in via giudiziale per il pregiudizio subito.

7 - Forza maggiore.

7.1. Il FABBRICANTE non è responsabile nei confronti dell'Acquirente per ogni inadempimento, compresa la mancata o ritardata consegna, causata da eventi al di fuori del suo ragionevole controllo quali, a titolo meramente indicativo, mancata o ritardata consegna dei materiali di lavorazione da parte dei fornitori, guasti agli impianti, scioperi e altre azioni sindacali, interruzione dei flussi energetici, sospensione o difficoltà nei trasporti.

8 - Diritto applicabile – Foro competente.

8.1. I contratti di vendita all'esportazione cui sia parte il FABBRICANTE sono regolati, per tutto quanto non previsto dalle presenti Condizioni Generali di Vendita, dalla Convenzione di Vienna dell'11 aprile 1980 sui Contratti di vendita internazionale di beni mobili. 8.2. Foro competente per tutte le controversie relative alle vendite di PRODOTTI da parte del FABBRICANTE e dei rapporti connessi a tali vendite è il FORO di Modena anche qualora l'azione promossa riguardi titoli di credito rilasciati al FABBRICANTE quali mezzi di pagamento. Il Fabbricante si riserva tuttavia il diritto di adire il Foro del luogo in cui ha sede l'acquirente, per il recupero dei crediti relativi alle forniture di Prodotti.

CONDITIONS GENERALES DE VENDE (En cas de litiges résultant de la traduction, qui est fournie à titre gracieux, le seul texte italien fera foi.)

1 - APPLICABILITE DES CONDITIONS

1.1. Les présentes conditions générales (ci-après dénommées "les CONDITIONS") constituent partie intégrante de tous les contrats de ventes des carrelages et autre matériel de céramique (ci-après dénommés "le/les PRODUITS") dont fait partie la Société Panariagroup Industrie Ceramiche S.p.A. – divisione Lea Ceramiche. (ci-après dénommé "le FABRICANT"). A l'exception des cas où elles sont dérogées avec des accords écrits et signés par le FABRICANT, celles-ci constituent le règlement exclusif régissant les ventes. Si une ou plusieurs parties des présentes CONDITIONS ou de chaque contrat qui les inclut s'avérait non valable, les CONDITIONS générales ou particulières resteront valables dans leur ensemble; les parties non valables seront remplacées par des accords s'approchant le plus possible de la volonté d'origine des parties.

2 - CONCLUSION DU CONTRAT DE VENDE - LIVRAISON DES PRODUITS

2.1. Le contrat est considéré conclu au moment où le proposant et le commandant ont connaissance du consentement écrit de la contrepartie. 2.2. La commande non confirmée par écrit ne pourra en aucun cas être considérée comme acceptée, sauf exécution de celle-ci par le FABRICANT par l'expédition ou la livraison des PRODUITS. La livraison partielle des PRODUITS commandés n'implique pas l'acceptation de la commande entière, mais uniquement de la partie des PRODUITS effectivement livrée. 2.3. Sauf accord différent écrit, la livraison des PRODUITS et leur retour en Italie et à l'étranger se fera selon la formule "Franco Usine". Cette formule, comme les autres formules de retour qui seraient convenues par écrit en remplacement de celle-ci, font référence aux "Incoterms" de la Chambre de Commerce Internationale de Paris, dans l'édition en vigueur au moment de la vente. 2.4. Sauf accord différent, toutes les dates indiquées comme délais de livraison sont considérées à titre indicatif.

3 - CARACTERISTIQUES DES PRODUITS - GARANTIE - RECLAMATIONS

3.1. Les carrelages en céramique et autres produits de céramique fabriqués par Panariagroup Industrie Ceramiche S.p.A. – divisione Lea Ceramiche sont conformes aux normes européennes UNI-DIN-EN. Le FABRICANT vend exclusivement à des revendeurs professionnels; ceux-ci sont responsables de l'exactitude des renseignements techniques fournis aux utilisateurs finaux et/ou négociants au détail. La classification du produit est indiquée par le FABRICANT sur le matériel publicitaire et/ou sur les listes des prix, l'acheteur doit en conséquence utiliser les PRODUITS sur la base de la classification fournie par le FABRICANT. Pour faciliter les indications d'utilisation, et adapter la classification standard aux spécificités de la production du FABRICANT, des symboles sont employés dans les catalogues et sur les listes de prix pour indiquer l'utilisation spécifique conseillée par le FABRICANT pour chaque produit. 3.2. Les différences de tonalités ne sont pas un défaut du PRODUIT mais une caractéristique du matériel spécifique cuit à haute température. La demande particulière d'ingelivité s'applique seulement aux PRODUITS que le FABRICANT garantit expressément avec une indication spéciale sur le matériel publicitaire et/ou sur les catalogues. En défaut de telle indication les matériaux céramiques sont considérés seulement et uniquement pour utilisation interne ou quoiqu'il en soit dans des locaux protégés des intempéries. La garantie d'ingelivité a une durée de deux ans. 3.3. Les matériaux en céramique avec une superficie brillante ne peuvent jamais être utilisés dans des locaux au rez-de chaussée avec accès à l'extérieur, ni dans des locaux où est prévu un grand piétinement. Les carrelages brillants sont de plus susceptibles d'être glissants, spécialement s'ils sont mouillés: le FABRICANT en déconseille par conséquent l'utilisation dans des locaux publics. Pour les locaux où il est prévu un grand piétinement l'acquéreur devra acheter seulement les PRODUITS classés par le FABRICANT comme PEI V, et en particulier les carrelages que le FABRICANT conseille spécifiquement pour utilisation dans des locaux publics. 3.4. Les représentations des PRODUITS sur les dépliant et autres matériels publicitaires du FABRICANT sont purement illustratives et ne représentent pas nécessairement le résultat esthétique final de pose du PRODUIT spécifique représenté. 3.5. Le FABRICANT garantit la bonne qualité et l'absence de vices des PRODUITS fournis. La garantie ne s'applique pas aux PRODUITS classés par le FABRICANT pour des qualités inférieures au premier choix ou pour des lots de PRODUITS de fin de série, vendus en bloc ou indiqués comme lots spéciaux. 3.6. Le FABRICANT n'est pas responsable pour les vices et/ou anomalies constatés sur des PRODUITS qui ne sont pas dus à la qualité des PRODUITS mêmes mais à l'utilisation impropre de ceux-ci de la part de l'acheteur et/ou de ses ayants cause. En particulier, le FABRICANT, n'accepte pas de réclamations ou de contestations en rapport avec les situations décrites précédemment. 3.7. Les réclamations doivent être transmises par l'acheteur au FABRICANT par écrit dans les 8 jours à compter de la livraison des marchandises. Pour des vices cachés le délai est de huit jours à compter de la découverte du vice. En aucun cas le FABRICANT ne répondra de vices n'ayant pas été dénoncés dans les 12 mois à compter de la date de la livraison des PRODUITS au premier acheteur du FABRICANT, et de conséquence l'action récursoire de l'acheteur contre le FABRICANT est limitée exclusivement dans le terme de 1 an à compter de la livraison des PRODUITS, étant expressément dérogé l'art. 1519-quinquies du code civil italien. 3.8 En général la garantie s'applique seulement pour les vices relevés sur les produits pas encore posés. Pour d'éventuels vices cachés relevés seulement après la pose, pour l'application de la garantie il est nécessaire que le FABRICANT vérifie que la pose soit faite selon toutes les règles de l'art. (norme DIN 18352). 3.9. La garantie du FABRICANT se limite au remplacement des produits défectueux par d'autres du même genre exempts de vices, transport inclus. Est exclu le remboursement des autres frais et/ou des dépenses accessoires et, en particulier, les coûts de démolition et de repose des PRODUITS. Dans tous les cas la garantie du FABRICANT ne peut pas dépasser cinq fois la valeur du matériel contesté avec un maximum absolu de 10.000,00 Euro. 3.10. Le FABRICANT ne répond pas pour des réclamations dues à une classification du matériel céramique de la part d'organismes de contrôle et/ou de certification différentes des classifications européennes indiquées dans l'art. 3.1 sur la base de techniques spécifiques qui ne correspondent pas à celles utilisées par le FABRICANT. D'éventuelles expertise techniques faites par les acheteurs devront nécessairement se baser sur la conformité du matériel vendu aux techniques spécifiques indiquées par le FABRICANT, en vigueur en Italie.

4 - PRIX ET CONDITIONS DE PAIEMENT

4.1. Les prix de vente des PRODUITS sont ceux indiqués sur la liste des prix du FABRICANT, en vigueur au moment de la confirmation de la commande. En cas des contrats de vente avec livraisons partielles, le prix s'il n'est pas convenu ferme par écrit, sera celui de la liste des prix en vigueur au moment de chacune des livraisons. Pour tous les PRODUITS destinés à l'étranger, les prix pourront être calculés, sur choix du FABRICANT, dans la devise étrangère du pays de destination ou en Euro. 4.2. Sauf accord différent, les paiements doivent être effectués par l'acheteur par virement bancaire, avant 30 jours de la date de la facture. Tous les frais bancaires et de négociation sont à la charge de l'acheteur. En cas de retard dans les paiements, le FABRICANT aura le droit de percevoir, sans aucune nécessité de mise en demeure, en plus des éventuels dommages, les intérêts de mise en demeure déterminés par l'Art.5 de D.Lgs n°231/2002

5 - AGENTS DU FABRICANT

5.1. Les agents du FABRICANT font la promotion des ventes et ne sont pas autorisés à agir au nom et pour le compte du FABRICANT, sauf autorisation écrite spécifique. 5.2. Les commandes transmises par les agents ne lient pas le FABRICANT et doivent donc être expressément acceptées par écrit par le FABRICANT lui-même.

6 - PROPRIETE RESERVEE

6.1. Il est convenu entre les parties que la vente des PRODUITS est effectuée avec réserve de propriété en faveur du FABRICANT jusqu'au paiement total du prix stipulé, aux termes de l'art. 1523 et suivants du Code Civil italien. Toutefois, le risque de péremption de la marchandise revient à l'acheteur au moment de la livraison des PRODUITS. Dans les ventes à l'étranger, au cas où la marchandise serait vendue et livrée à des tiers clients avant le passage de propriété, dans le cadre de rapports commerciaux habituels de la part de l'acheteur même, la réserve de propriété en faveur du FABRICANT demeure également envers les tiers, ou la loi le consent. 6.2. En cas de retard de paiement de l'acheteur le FABRICANT pourra, sans la nécessité d'aucune formalité, y compris la mise en demeure, retirer toute la marchandise objet de la réserve de propriété et, éventuellement, si la loi le consent, tous les titres de crédit envers les tiers afférents à celle-ci, sous réserve d'ultérieurs recours en justice pour le préjudice subi.

7 - FORCE MAJEURE

7.1. Le FABRICANT n'est pas responsable vis à vis de l'acheteur pour l'inaccomplissement, y compris l'absence ou le retard de livraison, causé par des événements hors de son contrôle tels que, à titre purement indicatif, des absences ou retards de livraison des matériaux de fabrication de la part des fournisseurs, des dommages aux installations, des grèves et autres actions syndicales, des interruptions de fourniture d'énergie, des arrêts ou des difficultés dans les transports.

8 - DROIT APPLICABLE - TRIBUNAL COMPETENT

8.1. Les contrats de vente à l'exportation dont fait partie le FABRICANT sont réglementés par tout ce qui n'est pas prévu par les présentes Conditions Générales de Ventes par la Convention de Vienne du 11 avril 1980 sur les contrats de vente internationale des biens mobiliers. 8.2. Le Tribunal compétent pour toutes les litiges concernant les ventes de PRODUITS de la part du FABRICANT et des rapports liés à ces ventes, est le Tribunal de Modena, même si l'action intentée concerne des titres de crédit remis au FABRICANT comme moyen de paiement. Le Fabricant se réserve le droit d'avoir recours au Tribunal du lieu où l'acheteur a son siège social, pour tout affaire concernant le recouvrement de créance des fournitures des Produits.

ALLGEMEINE VERKAUFSKONDITIONEN (Jede Übersetzung ist eine Unterstützung für Sie. Gültig ist immer die italienische Version.)

1. Anwendungsbereich:

1.1 Die vorliegenden allgemeinen Bedingungen (in der Folge „BEDINGUNGEN“ genannt) sind Vertragsinhalt aller Kaufverträge von Fliesen und anderen Keramikwaren (in der Folge „PRODUKTE“ genannt), bei denen die Firma Panariagroup Industrie Ceramiche S.p.A. – Division Lea Ceramiche (in der Folge „HERSTELLER“) Vertragspartei ist. Ausschließlich die vorliegenden Bedingungen regeln den Verkauf der PRODUKTE, doch ist es in Einzelfällen möglich, dass diese nicht zur Anwendung kommen, sofern das ausdrücklich schriftlich und nach Unterzeichnung des Herstellers vereinbart wird. Wenn einzelne oder mehrere Klauseln der BEDINGUNGEN oder wenn Verträge, die jene zum Inhalt haben, ungültig sind, bleiben die besonderen und allgemeinen BEDINGUNGEN in ihrer Gesamtheit gültig; die ungültigen Bestimmungen werden durch Vereinbarungen ersetzt, die dem ursprünglichen Parteiwillen am besten entsprechen.

2. Abschluss des Kaufvertrags – Warenlieferung

2.1 Der Vertrag gilt dann als abgeschlossen, sobald der Anbietende oder der Besteller Kenntnis über die schriftliche Zusage der Gegenpartei hat. 2.2. Eine schriftlich, nicht bestätigte Bestellung gilt in keinem Fall als angenommen, außer der HERSTELLER die PRODUKTE auf Grund der vorgenommenen Bestellung versendet oder liefert. Eine teilweise Lieferung der bestellten PRODUKTE führt nicht zu einer Annahme der gesamten Bestellung, sondern nur derjenigen PRODUKTE, die tatsächlich geliefert wurden. 2.3 Sofern nicht anderes vereinbart wurde, verläuft die Lieferung der PRODUKTE und ihre Bereitstellung in Italien und im Ausland „AB WERK“. Diese Regelung und alle davon auf Grund vertraglicher Vereinbarung abweichende Bedingungen beziehen sich auf die „INCOTERMS“ der internationalen Handelskammer in Paris, welche für den jeweiligen Warenverkauf Gültigkeit haben. 2.4 Sofern nicht anderes vereinbart wurde, sind alle Liefertermine nur Richtwerte.

3. Warenmerkmale – Garantie – Reklamationen

3.1. Die Keramikfliesen und andere von Panariagroup Industrie Ceramiche S.p.A. – Division Lea Ceramiche erzeugte Keramikwaren (PRODUKTE) entsprechen den europäischen „UNI-DIN-EN“-Normen und werden vom HERSTELLER ausschließlich an Großhändler verkauft, die für die Richtigkeit der technischen Informationen, die an die Letztverbraucher und Kleinhändler weitergegeben werden, verantwortlich sind. Die Güteklasse des Produkts wird vom HERSTELLER auf der Werbeunterlage und/oder Preisliste angegeben; der Erwerber hat daher die PRODUKTE gemäß den Angaben des HERSTELLERS zu gebrauchen. Um die Gebrauchshinweise zu vereinfachen und die Standardgüteklassen den besonderen Produktionsmerkmalen des HERSTELLERS anzupassen, werden jedes einzelne Produkt, sämtliche Preislisten und Kataloge mit Hinweisen ausgestattet, die auf den jeweils vom HERSTELLER empfohlenen Gebrauch aufmerksam machen. 3.2. Die unterschiedliche Farbtonung ist kein Zeichen für die Fehlerhaftigkeit des PRODUKTS, sondern eine spezifische Eigenschaft des Materials, das bei hohen Temperaturen gebrannt wurde. PRODUKTE haben nur dann die besondere Eigenschaft, frostbeständig zu sein, wenn der HERSTELLER dies ausdrücklich garantiert und dies aus der Werbeunterlage und/oder Preisliste hervorgeht. Wenn die Frostbeständigkeit nicht gesondert angezeigt wird, sind alle Keramikwaren nur für den Gebrauch in Innenbereichen und Bereichen bestimmt, die von den Unbilden des Wetters geschützt sind. Die Garantie für die Frostbeständigkeit des Produkts ist zwei Jahre lang gültig. 3.3. Die Keramikprodukte mit einer glanzpolierten Oberfläche dürfen weder in Bereichen verwendet werden, die sich im Erdgeschoss befinden und einen Zugang ins Freie haben, noch in Bereichen mit einer voraussichtlich hohen Trittbelastung. Zudem sind jene Fliesen nicht rutschfest, besonders dann, wenn sie feucht sind: der HERSTELLER empfiehlt daher, diese nicht in öffentlich zugänglichen Bereichen zu verwenden. Für Bereiche mit einer voraussichtlich hohen Trittbelastung soll der Käufer nur PRODUKTE erwerben, die vom HERSTELLER als „PEI V“ klassifiziert werden; das sind v.a. diejenigen Fliesen, die der HERSTELLER eigens für den Gebrauch in öffentlich zugänglichen Bereichen empfiehlt. 3.4. Die Abbildungen auf Faltprospekten oder anderen Werbeunterlagen dienen ausschließlich der Veranschaulichung der Produkte und stellen nicht notwendigerweise das ästhetische Endergebnis nach der Verlegung des einzelnen PRODUKTS dar. 3.5. Der HERSTELLER gewährleistet, dass die gelieferten PRODUKTE eine gute Qualität haben und fehlerfrei sind. Eine Gewährleistung für PRODUKTE kann nicht übernommen werden, sofern diese nach den Angaben des HERSTELLERS einer niedrigeren Qualität als die der ersten Sorte entsprechen oder als Auslaufprodukte einer besonderen Güteklasse angehören und Blockweise verkauft werden. 3.6 Der HERSTELLER haftet nicht für Mängel und/oder Unzulänglichkeiten der PRODUKTE, die nicht auf Qualitätsmängel, sondern auf den nicht fachgemäßen Gebrauch der Produkte von Seiten der Erwerber und/oder Rechtsnachfolger zurückzuführen sind. In diesem Fall kann der HERSTELLER auf solche Beschwerden und Reklamationen nicht eingehen. 3.7 Der Erwerber hat dem HERSTELLER alle Einwendungen schriftlich innerhalb von 8 Tagen nach Lieferung der Waren mitzuteilen. Für versteckte Mängel beträgt die Frist 8 Tage ab dem Zeitpunkt, in dem der Mangel entdeckt wurde. In keinem Fall haftet der HERSTELLER für Mängel, die 12 Monate nach Lieferung an den Erstkäufer des HERSTELLERS mitgeteilt worden sind. In diesem Fall hat der Händler, abweichend von Artikel 1519 - quinquies des italienischen Bürgerlichen Gesetzbuches, die Möglichkeit, den Regressanspruch gegen den HERSTELLER nur innerhalb eines Jahres ab Lieferung der Produkte vorzunehmen. 3.8 Im Allgemeinen bezieht sich die Gewährleistung ausschließlich auf Produkte, die noch nicht verarbeitet wurden. Im Falle von versteckten Mängeln, die erst nach der Verarbeitung auftreten, haftet der HERSTELLER nur dann, wenn dieser feststellt, dass die Verlegung fachgemäß durchgeführt wurde (siehe DIN 18352-Normen). 3.9 Die Gewährleistungspflicht des HERSTELLERS besteht darin, dass dieser die fehlerhaften Produkte mit anderen fehlerfreien ersetzt und den Transport dafür übernimmt. Der Hersteller ist nicht verpflichtet, andere Aufwendungen und zusätzliche Ausgaben zu ersetzen und im besonderen, die Kosten für die Abtragung und Neuverlegung der PRODUKTE zu übernehmen. Auf jeden Fall kann die Gewährleistung des HERSTELLERS nicht den fünffachen Wert des beanstandeten Materials mit einer Höchstgrenze von EURO 10.000,00 überschreiten. 3.10 Der HERSTELLER haftet nicht dafür, wenn nichteuropäische Zertifizierungs- und Prüfstellen aufgrund anderer, nicht in Punkt 3.1 erläuterten und vom HERSTELLER verwendeten technischen Kriterien die Produkte einer anderen Güteklasse zuordnen. Allfällige technische Gutachten von Seiten der Erwerber müssen dabei beachten, dass die Bewertung der verkauften Ware mit denselben technischen Kriterien erfolgt, wie sie vom HERSTELLER erläutert wurden und in Italien gültig sind.

4. Preise und Zahlungsbedingungen

4.1. Die Verkaufspreise der PRODUKTE sind aus der jeweiligen Preisliste des HERSTELLERS ersichtlich, die zum Zeitpunkt der Auftragsbestätigung gerade gültig ist. Im Fall von Verkaufsverträgen mit mehreren Lieferungen (Rahmenvverträge) gelten diejenigen Preise, die sich aus den zum Zeitpunkt der einzelnen Lieferungen gültigen Preislisten ergeben, sofern nicht schriftlich ein fester Preis festgelegt wird. Die Preise der für das Ausland bestimmten PRODUKTE können je nach Wahl des HERSTELLERS in der Währung des Bestimmungslandes oder in Euro festgelegt werden. 4.2. Vorbehaltlich anderlautender Abkommen sind die Bezahlungen des Käufers mittels Banküberweisung innerhalb 30 Tage ab Rechnungsdatum vorzunehmen. Alle Bank- und Begebungsgebühren hat der Käufer zu übernehmen. Falls die Bezahlung nicht fristgemäß erfolgt, hat der HERSTELLER das Recht auf Schadenersatz und Erhebung von Verzugszinsen, die auf der Basis des italienischen offiziellen Diskontsatzes plus 5 Prozentpunkte errechnet werden; dazu ist nicht erforderlich, dass der Käufer aufgrund einer Mahnung in Verzug kommt; der Zahlungsverzug für ins Ausland verkaufte Waren hat für den HERSTELLER die Erhebung von Verzugszinsen Art.Svom D. Lgs n. 231/2002

5. Handelsvertreter des Herstellers.

5.1 Die Handelsvertreter des HERSTELLERS treiben den Verkauf voran, haben aber, vorbehaltlich einer schriftlichen Erlaubnis, nicht das Recht, im Namen und auf Rechnung des HERSTELLERS tätig zu werden. 5.2 Die von den Handelsvertretern getätigten Bestellungen sind für den HERSTELLER nicht verbindlich und müssen daher vom HERSTELLER ausdrücklich in schriftlicher Form angenommen werden.

6. Eigentumsvorbehalt

6.1. Es wird zwischen den Parteien vereinbart, dass die verkaufte Ware bis zum vollständigen Ausgleich des Preises Eigentum des HERSTELLERS auf der Grundlage des Eigentumsvorbehalts im Art. 1523 des italienischen Bürgerlichen Gesetzbuchs bleibt. Hingegen geht die Gefahr für die Verschlechterung der Ware schon zum Zeitpunkt der Lieferung der PRODUKTE an den Käufer über. Wenn bei Verkäufen ins Ausland die Ware an dritte Kunden verkauft und vor der Eigentumsübertragung geliefert wird, bleibt bei normalen Handelsbeziehungen des Käufers der Eigentumsvorbehalt zugunsten des HERSTELLERS auch gegenüber Dritte aufrecht, sofern dies das Gesetz zulässt. 6.2. Kommt der Käufer in Verzug, hat der HERSTELLER das Recht, ohne Einhaltung besonderer Formvorschriften und ohne Mahnung an den Käufer alle Waren mit Eigentumsvorbehalt zurückzufordern und – sofern es gesetzlich möglich ist – alle auf den Waren haftende Schuldbriefe gegenüber Dritte zurückzuziehen. Dabei behält sich der Hersteller vor, auf gerichtlichem Wege Ersatz für den erlittenen Schaden zu fordern.

7. Höhere Gewalt.

7.1. Der HERSTELLER übernimmt gegenüber dem Käufer keine Haftung für Nichterfüllungen und mangelnde oder verspätete Lieferungen, die aufgrund eines vom Hersteller nicht beeinflussbaren Ereignisses hervorgerufen wurden; hier seien u.a. nur einige aufgezählt: mangelnde oder verspätete Lieferung von Herstellungsmaterialien von seiten der Zulieferer, Schäden an den Geräten, Streiks und andere gewerkschaftliche Tätigkeiten, Unterbrechung der Energieversorgung, Unterbrechung bzw. Schwierigkeiten im Transport.

8. Anzuwendendes Recht – zuständiges Gericht.

8.1 Die für den Export von Waren vereinbarten Kaufverträge, in denen der HERSTELLER Parteienstellung hat, werden vom Wiener Übereinkommen vom 11. April 1980 über die Verträge über den internationalen Warenverkauf geregelt, sofern für diese nicht die vorliegenden Allgemeinen Verkaufsbedingungen zur Anwendung kommen. 8.2 Für alle Rechtsstreitigkeiten, die sich auf den Verkauf der PRODUKTE von seiten des HERSTELLERS und auf die damit in Verbindung stehenden Rechtsverhältnisse bezieht, ist der GERICHTSSTAND von Modena zuständig. Dies gilt auch für die Erhebung von Klagen in Bezug auf Schuldbriefen, die dem HERSTELLER zur Bezahlung ausgestellt wurden. Der Hersteller behält sich jedoch das Recht, sich auf das im Ort des Einkäufers zuständige Gericht zu beziehen, um Forderungen bezüglich der Produktlieferungen einzutreiben.

GENERAL SALES CONDITIONS (In case of divergences in the translations the Italian version prevails.)

1 – APPLICATION OF THE CONDITIONS

1.1. The following general conditions (hereinafter "the CONDITIONS") constitute an integral part of the sales contract of tiles and other ceramic products (hereinafter "the PRODUCT or PRODUCTS") manufactured by Panariagroup Industrie Ceramiche S.p.A. - Lea Ceramiche division (hereinafter "the MANUFACTURER"). Except for specific cases, where these conditions are expressly derogated by written agreements signed by the MANUFACTURER, they represent the only terms for these sales. If one or more parts of these CONDITIONS, or single contracts included therein, are found to be invalid, the CONDITIONS, or details thereof, will remain valid as a whole; the invalid terms will be replaced with new agreements, which will reproduce, as far as it is possible, the original intention of the parties.

2 - EXECUTION OF THE SALES CONTRACT - DELIVERY OF PRODUCTS

2.1. The contract is executed when the proposing party or the purchaser is aware of the written consent of the other party. 2.2. An order that has not been confirmed in writing cannot, under any circumstances, be considered as accepted, unless performed by the MANUFACTURER by way of the shipment or delivery of the PRODUCTS. The partial delivery of ordered PRODUCTS does not imply the acceptance of the entire order, but only that part of the PRODUCTS which has been effectively delivered. 2.3. Unless otherwise agreed in writing, the delivery of the PRODUCTS in Italy or abroad, will be carried out according to the "Ex-Works" term. This term of delivery, as well as the other terms of delivery which may be agreed upon in writing, is referred to the ICC INCOTERMS in force at the moment of the sale. 2.4. Unless otherwise agreed, all the dates which are indicated for delivery, shall be considered as approximate.

3 - PRODUCT SPECIFICATIONS - WARRANTY - CLAIMS

3.1. The PRODUCTS manufactured by Panariagroup Industrie Ceramiche S.p.A. - Lea Ceramiche division are produced according to the European UNI-DIN-EN rules. The MANUFACTURER sells exclusively to professional dealers; these are responsible for giving the right technical information to the final user or retailers. The PRODUCTS classifications are indicated by the MANUFACTURER on advertising material and/or in the price lists. Therefore the purchaser must use the PRODUCTS according to the specifications of the MANUFACTURER. In order to ease the suggestions of use and conform the standard classifications to the specific production of the Manufacturer, on every product, price-list or catalogue there are specific symbols that indicate the intended use suggested by the MANUFACTURER. 3.2. The shade differences are not a defect of the PRODUCT, but a specific characteristic of the material which has been fired at a high temperature. The special "freeze -proof" requirement does only apply to PRODUCTS that the MANUFACTURER has specifically guaranteed by giving specific indication on the advertising material and/or price lists. Without this specific indication the PRODUCTS shall be considered to be only and exclusively for internal use or, in any case, to be used in places not exposed to the elements. The "freeze -proof" warranty has a two years term. 3.3. The tiles with polished surfaces can never be used on ground floor rooms that have external access, nor in rooms where there is a particular heavy walking. The shiny tiles may also be slippery, especially when wet; for this reason the MANUFACTURER recommend not to use these PRODUCTS in public places. For places intended to heavy walking, the purchaser shall only buy PRODUCTS classified by the MANUFACTURER as PEI V, and in particular those PRODUCTS that the MANUFACTURER

specifically recommends for use in public places. 3.4. The representations of PRODUCTS on depliants and other advertising material of the MANUFACTURER, are solely illustrative and do not represent necessarily the final aesthetic result of the laying of that specific PRODUCT. 3.5. The MANUFACTURER guarantees the good quality and the absence of defects of the PRODUCTS supplied. The warranty does not apply to PRODUCTS classified by the MANUFACTURER as inferior to the 1st choice quality, or to stocks of PRODUCTS which are gone out of production, when sold in bulk or indicated as special lot. 3.6. The MANUFACTURER shall not be liable for any defects and/or anomalies in the PRODUCTS due not to the quality of the PRODUCTS, but to the improper use of the PRODUCTS by the purchasers and/or third parties acting on their behalf. In particular, the MANUFACTURER shall not accept any claim or disputes in connection with the situations above described. 3.7. The claims must be notified in writing to the MANUFACTURER by the purchaser within eight (8) days from the date of delivery of the goods. In case of hidden defects the notice period will be eight (8) days from the date of the discovery of the defect. Under no circumstances the MANUFACTURER shall be liable for defects which are discovered twelve months after the delivery of the PRODUCTS to the first Purchaser of the MANUFACTURER and therefore the Purchaser's recourse action against the MANUFACTURER is exclusively limited within 1 year from delivery of the goods, being expressly derogated art. 1519-quinquies of the Italian civil code. 3.8. In principle, the warranty does only apply to defect discovered on PRODUCTS not yet laid down. For hidden defects discovered after the PRODUCTS had been laid down, the warranty may apply only if the MANUFACTURER has verified that the laying of the PRODUCT has been done according to the best knowledge of workmanship (DIN 18352). 3.9. The warranty given by MANUFACTURER is limited to the replacement of defective products with other non-defective of the same type, plus the transportation costs. It is expressly excluded the reimbursement of any other costs and/or expenses and in particular the costs of demolition and relaying. In all circumstances, the warranty of the MANUFACTURER cannot exceed five times the value of the claimed material, up to a maximum of Euro 10.000,00. 3.10. The MANUFACTURER shall not be liable for claims due to a classification of ceramics materials made by organisms of certification and control different from the European ones indicated in art. 3.1., on the basis of technical specifications which do not correspond with those indicated by the MANUFACTURER. Any eventual technical expertise requested by the purchaser, shall be based on the correspondence of the materials sold with the technical specifications indicated by the MANUFACTURER, at that time in force in Italy.

4 - PRICES AND PAYMENT CONDITIONS

4.1. The selling prices of the PRODUCTS are those indicated in the MANUFACTURER's price list in force at the date of the order's confirmation. For sales contracts with separate deliveries the price, unless otherwise agreed in writing, will be the price list in force at the time of each delivery. For the PRODUCTS which are intended for foreign markets the price shall be calculated, at the MANUFACTURER choice, in the foreign currency of the country of destination or in Euro. 4.2. Unless otherwise agreed, payments shall be made by the purchaser through bank transfer, within 30 days from the date of the invoice. All the bank and negotiation expenses are at purchaser's charge. In case of delay in payment, the MANUFACTURER, along with any other damages, shall be entitled, without any prior notice to the purchaser, to an overdue interest in accordance with Art5. of D.LGS n°231.2002

5 - MANUFACTURER'S AGENTS

5.1. The agents of the MANUFACTURER promote the sales of the products and are not authorized to act in the name and on behalf of the MANUFACTURER, unless specific written authorization. 5.2. The orders collected by the agents are not binding for the MANUFACTURER, and shall therefore be expressly accepted in writing by the MANUFACTURER itself.

6 - RETENTION OF TITLE

6.1. It is agreed between the parties that the sale of PRODUCTS is made under the retention of title right of the MANUFACTURER until the complete payment of the agreed price has been made by the purchaser, according to Article 1523 (and following) of the Italian Civil Code. However, the risk of the loss of the goods is transferred to the purchaser at the moment of the delivery of the PRODUCTS. In case of sales into foreign countries, when the goods are sold and delivered to third parties within the Purchaser's normal commercial activities and the property of the goods has not been yet transferred, the retention of title right of the MANUFACTURER still remains valid also against third parties, if permitted by the law. 6.2. In case of delay in payments the MANUFACTURER is entitled, without any formality, including any prior notice to the purchaser, to collect all the goods subject to the retention of title and, if permitted by the law, all the relating documents of credit toward third parties, being expressly reserved the right of the Manufacturer to proceed at law for the compensation of the damages suffered.

7 - FORCE MAJEURE

7.1. The MANUFACTURER shall not be liable to the purchaser for any unfulfilment of the contract, including the non-delivery or delayed delivery, caused by events that are out of the MANUFACTURER's reasonable control, such as, for example the non-delivery or delayed delivery of working materials by the suppliers, factory breakdowns, strikes or other trade union actions, interruption of energy supplies, suspension or difficulties with transports.

8 - APPLICABLE LAW - COMPETENT COURT

8.1. The export sales contracts in which the MANUFACTURER takes part are governed, where not derogated by the present CONDITIONS, by the Vienna Convention of April 11th 1980 on the International Sales Contracts. 8.2. For any disputes relating to the sale of PRODUCTS of the MANUFACTURER and all other related issues, the only competent Court is the one of Modena, also for what concerns the enforcement of documents of credit received by the MANUFACTURER as a mean of payment. The Manufacturer reserves the right to act before the Court where the purchaser has its registered office, for any credit collection suit relating to Products supplies.

Le rappresentazioni fotografiche e descrittive dei prodotti di Lea Ceramiche riportate sui depliant, sui cataloghi e sugli altri materiali pubblicitari dell'azienda, sono puramente illustrative dello specifico prodotto rappresentato.

Si precisa infatti che, successivamente alla pubblicazione dei materiali pubblicitari dell'azienda, il prodotto potrebbe subire leggere modifiche nel relativo processo produttivo, al fine di renderlo tecnologicamente migliore. Tali aggiustamenti tecnologici potrebbero determinare lievi differenze, anche estetiche e/o cromatiche, nel prodotto medesimo, con la conseguenza che lo stesso potrebbe risultare diverso da come rappresentato e/o illustrato e/o descritto nel materiale pubblicitario di Lea Ceramiche. Tali differenze non potranno essere in alcun modo considerate dall'acquirente un vizio e/o difetto del materiale ceramico stesso, bensì una caratteristica dello specifico prodotto.

Tutti i materiali ceramici che imitano pietre naturali presentano differenze di colore e sfumature che non potranno in nessun modo essere considerate quale difetto del prodotto, ma bensì una qualità caratteristica di tali tipi di produzione.

The photographs and descriptions of Lea Ceramiche products given in the brochures, catalogues and other corporate advertising materials aim merely to represent the specific products.

After the publication of the corporate advertising materials, the products may be slightly modified as a result of technological improvements. Such technological modifications may lead to slight differences in appearance and/or colour of the products, which may therefore differ from the representations, illustrations or descriptions given in the Lea Ceramiche advertising materials. Such differences shall in no way be deemed to be faults and/or defects in the ceramic materials, but rather intrinsic features of the specific products.

All ceramic materials that imitate natural stone differ in color and nuances, and this cannot in any way be considered as a product defect, but rather a characteristic of these types of products.

Les représentations photographiques et descriptives des produits de Lea Ceramiche reportées au sein des dépliant, des catalogues et des autres matériels publicitaires de l'entreprise visent simplement à illustrer le produit spécifique représenté.

En effet, nous précisons que suite à la publication des matériels publicitaires de l'entreprise, le produit pourrait subir de légères modifications lors du processus de production afin de le rendre meilleur du point de vue technologique. Ces ajustements technologiques pourraient engendrer de légères différences, même esthétiques et/ou chromatiques, au niveau du produit même, impliquant que celui-ci pourrait diverger des représentations et/ou des illustrations et/ou des descriptions contenues dans le matériel publicitaire de Lea Ceramiche. Ces différences ne pourront en aucun cas être considérées par l'acquéreur comme une imperfection et/ou un défaut du matériau céramique, mais plutôt comme une caractéristique du produit spécifique.

Tous les matériaux céramiques imitant les pierres naturelles présentent des différences de couleur et des nuances qui ne pourront en aucun cas être considérés comme un défaut du produit, mais, en revanche, comme une caractéristique typique de ces productions.

Die in den Prospekten, Katalogen und sonstigen Werbematerialien der Firma enthaltenen fotografischen Darstellungen und Beschreibungen der Produkte von Lea Ceramiche dienen nur zur Veranschaulichung des jeweils dargestellten Produkts.

Wir weisen darauf hin, dass nach der Veröffentlichung der Werbematerialien der Firma leichte Änderungen bezüglich des Produktionsprozesses am Produkt vorgenommen werden könnten, um es in technologischer Hinsicht zu verbessern. Diese technischen Abänderungen könnten zu leichten z.B. ästhetischen und/oder farblichen Unterschieden am Produkt führen, das folglich von dem im Werbematerial von Lea Ceramiche dargestellten und/oder veranschaulichten und/oder beschriebenen Produkt abweichen könnte. Diese Unterschiede dürfen vom Käufer in keiner Weise als Mangel und/oder Defekt des Keramikmaterials angesehen werden, sondern sind ein Merkmal des spezifischen Produkts.

Die keramischen Materialien die Natursteine nachbilden (imitieren), die Farbunterschieden haben, sind nicht als Fehler des Materials zu bezeichnen, sondern als typische Merkmale.

imballi / articoli / fondi - packing / items / plain tiles

Gres Laminato Slimtech			scatola			pallet			
formato	serie	spessore	pz/co	mq/co	kg/co	co/pl	mq/pl	kg/pl	
100x300	3plus	slimtech	3,5mm	1	3,00	25,4	12	36,0	304,2
100x300	3mm	slimtech	3mm	1	3,00	22,2	13	39,0	288,6
33x300	5plus	slimtech	5,5mm	1	0,99	12,5	24	23,8	299,7
20x200	5plus	slimtech	5,5mm	3	1,20	15,0	40	48,0	600,0
50x150	3plus	slimtech	3,5mm	5	2,25	18,0	20	45,0	360,0
20x150	5plus	slimtech	5,5mm	3	0,90	11,3	60	54,0	675,0
100x100	3plus	slimtech	3,5mm	3	3,00	24,1	25	75,0	602,5
50x100	3plus	slimtech	3,5mm	5	2,50	20,0	32	80,0	640,0
50x100	3mm	slimtech	3mm	5	2,50	17,8	32	80,0	569,6
33,3x100	3plus	slimtech	3,5mm	5	1,67	13,0	35	58,3	455,0
20x100	5plus	slimtech	5,5mm	3	0,60	7,5	60	36,0	450,0
4,9x100	3plus	slimtech	3,5mm	10	0,49	4,2	39	19,1	163,8
4,9x100	3mm	slimtech	3mm	10	0,49	4,0	39	19,1	156,0
50x50	3plus	slimtech	3,5mm	7	1,75	14,0	48	84,0	672,0

Gres Porcellanato			scatola			pallet			
formato	serie	spessore	pz/co	mq/co	kg/co	co/pl	mq/pl	kg/pl	
60x120	rtt	basaltina - tecnoquartz	12mm	2	1,44	40,8	24	34,6	979,2
60x120	rtt	arenaria	11mm	2	1,44	37,0	24	34,6	888,0
60x120	rtt	origini	10mm	2	1,44	35,5	24	34,6	852,0
30x120	rtt	origini	10mm	3	1,08	25,5	32	34,6	816,0
20x120	rtt	bioessenze	12mm	4	0,96	26,3	36	34,6	946,4
20x120	rtt	bio plank - bio timber	11mm	4	0,96	24,5	36	34,6	882,0
15x120	rtt	bioessenze	12mm	6	1,08	28,7	32	34,6	918,4
15x120	rtt	bio plank - bio timber	11mm	6	1,08	26,5	32	34,6	848,0
12x120	rtt	bio plank	11mm	6	0,86	22,5	40	34,6	900,0
90x90	rtt	blue mountain - metropolis	11mm	2	1,62	40,0	24	38,9	960,0
45x90	rtt	blue mountain - metropolis	11mm	3	1,22	30,0	27	32,8	810,0
30x90	rtt	blue mountain	11mm	3	0,81	20,0	27	21,9	540,0
22,5x90	rtt	blue mountain	11mm	4	0,81	20,0	46	37,3	920,0
15x90	rtt	blue mountain	11mm	6	0,81	20,0	45	36,5	900,0
10x90	rtt	blue mountain	11mm	9	0,81	20,0	40	32,4	800,0
9x90	rtt	bioessenze	10mm	13	1,05	23,4	48	50,5	1123,2
75x75	rtt	dreaming	11mm	2	1,13	28,5	40	45,0	1140,0
75x75	rtt	salento - blue mountain - stonehenge - basaltina - metropolis	11mm	2	1,13	27,4	40	45,0	1096,0
37,5x75	rtt	salento - blue mountain	11mm	5	1,41	34,3	32	45,0	1096,0
60,4x60,4	nat	arenaria - salento - blue mountain	10mm	4	1,46	32,0	32	46,7	1024,0
60x60	rtt	tecnoquartz	12mm	4	1,44	36,6	24	34,6	879,4
60x60	nat	stonehenge - storm	11mm	4	1,44	35,0	24	34,6	840,0
60x60	rtt	makò - stonehenge - storm - basaltina	11mm	4	1,44	35,0	24	34,6	840,0
60x60	rtt	origini	10mm	4	1,44	35,5	32	46,1	1136,0
60x60	rtt	salento - blue mountain - metropolis - dreaming - arenaria	10mm	4	1,44	32,0	32	46,1	1024,0
40x60	rtt	tecnoquartz	12mm	4	0,96	24,6	24	23,0	589,4
30x60,4	nat	salento - blue mountain	10mm	8	1,45	32,0	32	46,4	1024,0
30x60,4	nat	arenaria - storm	9mm	9	1,63	32,4	32	52,2	1036,8
30x60	rtt	tecnoquartz	12mm	7	1,26	32,5	32	40,3	1040,0
30x60	rtt	basaltina - makò - stonehenge - storm	11mm	8	1,44	34,9	32	46,1	1116,8
30x60	rtt	origini	10mm	8	1,44	35,5	32	46,1	1136,0
30x60	rtt	arenaria - salento - blue mountain - metropolis - dreaming	10mm	8	1,44	32,0	32	46,1	1024,0
20x60	rtt	tecnoquartz	12mm	7	0,84	21,2	48	40,3	1017,6
9,7x60	rtt	stonehenge - makò	11mm	13	0,76	19,2	60	45,4	1152,0
5,7x60	rtt	stonehenge	11mm	13	0,44	11,3	80	35,6	904,0
48,5x48,5	nat	ancient jerusalem - rain forest	10mm	6	1,41	31,6	24	33,9	758,4
32,2x48,5	nat	ancient jerusalem - rain forest	10mm	7	1,09	23,1	44	48,1	1016,4
45x45	nat	storm	9mm	7	1,42	28,0	52	73,7	1456,0
20x40,4	nat	outdoor	9mm	13	1,05	21,1	54	56,7	1139,4
32,2x32,2	nat	ancient jerusalem - rain forest	10mm	12	1,25	28,0	42	52,3	1176,0
15,9x32,2	nat	ancient jerusalem	10mm	24	1,23	28,0	48	59,0	1344,0
30x30	rtt	tecnoquartz	12mm	12	1,08	27,2	38	41,0	1035,1
30x30	nat	storm	9mm	15	1,35	26,2	40	54,0	1048,0
30x30	rtt	storm	11mm	11	0,99	22,9	40	39,6	917,2
20x30,2	nat	outdoor	9mm	20	1,21	24,2	48	58,0	1161,6
20x30	rtt	tecnoquartz	12mm	12	0,72	17,8	60	43,2	1065,6
20x20	nat	outdoor	9mm	30	1,20	24,0	45	54,0	1080,0
15,9x15,9	nat	ancient jerusalem - rain forest	10mm	48	1,21	27,0	48	58,2	1296,0

Monoporosa in pasta bianca			scatola			pallet			
formato	serie	spessore	pz/co	mq/co	kg/co	co/pl	mq/pl	kg/pl	
35x100	rtt	athena - kalos	12mm	3	1,05	22,0	26	27,3	570,7
35x70	rtt	pleasures - très jolie - audrey	10,8mm	4	0,98	18,1	56	54,9	1013,6
31x62	nat	kensington - mayfair	10mm	6	1,15	19,6	40	46,1	784,0
31x62	nat	kensington jewel - mayfair jewel	13mm	4	0,77	15,9	40	30,8	635,2
31x62	nat	kensington plank, brick	10mm	6	1,15	19,6	40	46,1	784,0
31x62	nat	kensington square	11,5mm	5	0,96	18,5	40	38,4	740,0
35x35	rtt	pleasures - très jolie - audrey	9mm	9	1,10	21,3	24	26,4	511,2
35x35	rtt	athena - kalos	9mm	9	1,10	21,2	24	26,4	508,8
30x32	nat	paillettes	5mm	10	0,96	12,5	26	25,0	325,0
31x31	nat	kensington - mayfair	7,8mm	13	1,25	21,3	50	62,5	1062,5
20x40	nat	progetto L14 double 24	9mm	21	1,68	25,5	48	80,6	1225,9
20x40	nat	progetto L14 mood 24	9mm	21	1,68	28,4	48	80,6	1363,2
20x40	nat	progetto L14 preinciso note 24	9mm	12	0,96	14,5	36	34,6	522,4
10x40	nat	progetto L14 mood 14	9mm	18	0,72	11,9	60	43,2	714,0

Travertino e marmo naturali al 100%			scatola			pallet		
formato	serie	spessore	pz/co	mq/co	kg/co	co/pl	mq/pl	kg/pl
30,5x30,5	tesserae	4mm	5	0,47	3,8	144	67,0	540,0
30,5x30,5	tesserae 3D	4mm	5	0,47	5,0	108	50,2	540,0

Tutti i dati relativi gli imballi indicati nel presente listino sono da ritenersi puramente indicativi e potrebbero subire variazioni.
All information regarding packaging in this pricelist are considered purely indicative and subject to change.

LEA

CERAMICHE

LEA CERAMICHE

Via Cameazzo, 21
41042 Fiorano Modenese
Modena Italy

Tel +39 0536 837811
Fax +39 0536 830326
info@ceramichelea.it
www.ceramichelea.com
slimtech.ceramichelea.it

Panariagroup Industrie Ceramiche S.p.A.

SHOWROOM LEA CERAMICHE

Via Durini, 3
20122 Milano

Tel +39 02 76011406
showroom_milano@ceramichelea.it

LEA NORTH AMERICA, LLC

800 Clanton Road, Suite N
Charlotte, NC 28217

Tel +1 704 522 6300
Fax +1 704 522 6080
info@leausa.us